

GSM RTC

Application Note

GSM/GPRS Module Series

Rev. GSM_RTC_Application_Note_V1.1

Date: 2015-04-11



Our aim is to provide customers with timely and comprehensive service. For any assistance, please contact our company headquarters:

Quectel Wireless Solutions Co., Ltd.

Office 501, Building 13, No.99, Tianzhou Road, Shanghai, China, 200233

Tel: +86 21 5108 6236

Mail: info@quectel.com

Or our local office, for more information, please visit:

<http://www.quectel.com/support/salesupport.aspx>

For technical support, to report documentation errors, please visit:

<http://www.quectel.com/support/techsupport.aspx>

Or Email: Support@quectel.com

GENERAL NOTES

QUECTEL OFFERS THIS INFORMATION AS A SERVICE TO ITS CUSTOMERS. THE INFORMATION PROVIDED IS BASED UPON CUSTOMERS' REQUIREMENTS. QUECTEL MAKES EVERY EFFORT TO ENSURE THE QUALITY OF THE INFORMATION IT MAKES AVAILABLE. QUECTEL DOES NOT MAKE ANY WARRANTY AS TO THE INFORMATION CONTAINED HEREIN, AND DOES NOT ACCEPT ANY LIABILITY FOR ANY INJURY, LOSS OR DAMAGE OF ANY KIND INCURRED BY USE OF OR RELIANCE UPON THE INFORMATION. ALL INFORMATION SUPPLIED HEREIN IS SUBJECT TO CHANGE WITHOUT PRIOR NOTICE.

COPYRIGHT

THIS INFORMATION CONTAINED HERE IS PROPRIETARY TECHNICAL INFORMATION OF QUECTEL CO., LTD. TRANSMITTABLE, REPRODUCTION, DISSEMINATION AND EDITING OF THIS DOCUMENT AS WELL AS UTILIZATION OF THIS CONTENTS ARE FORBIDDEN WITHOUT PERMISSION. OFFENDERS WILL BE HELD LIABLE FOR PAYMENT OF DAMAGES. ALL RIGHTS ARE RESERVED IN THE EVENT OF A PATENT GRANT OR REGISTRATION OF A UTILITY MODEL OR DESIGN.

Copyright © Quectel Wireless Solutions Co., Ltd. 2015. All rights reserved.

About the Document

History

Revision	Date	Author	Description
1.0	2015-03-04	Winter CHEN	Initial
1.1	2015-04-11	Winter CHEN	Added applicable modules

Quectel
Confidential

Contents

About the Document.....	2
Contents.....	3
Table Index.....	4
Figure Index.....	5
1 Introduction	6
2 Time Synchronization.....	7
2.1. Hardware Interface	7
2.2. RTC Power Source.....	7
2.3. Time Synchronization by NITZ or NTP.....	9

Quectel
Confidential

Table Index

TABLE 1: VRTC INTERFACE..... 7
TABLE 2: GSM MODULE POWER-DOWN CONSUMPTION FEATURES 7

Quectel
Confidential

Figure Index

FIGURE 1: RTC IS SUPPLIED BY VBAT.....	8
FIGURE 2: RTC IS SUPPLIED BY A BACKUP POWER	8

Quectel
Confidential

1 Introduction

This document introduces interface specifications and electrical characteristic of RTC, which will help you get an accurate time in different RTC application condition.

This document is applicable to Quectel M10, M66, M95, M85 and M72 modules.

Quectel
Confidential

2 Time Synchronization

2.1. Hardware Interface

Table 1: VRTC Interface

Pin Name	I/O	Description	DC Characteristics	Comment
VRTC	I/O	Power supply for RTC power domain	VImax=3.3V VImin=1.5V VInorm=2.8V VOmax=3V VOmin=2V VOnorm=2.8V Iout(max)=2mA Iin≈10uA	If unused, keep this pin open.

Table 2: GSM Module Power-down Consumption Features

Function	GSM Module
Power Down Current Consumption on VBAT	150uA
VRTC Current Consumption	10uA

2.2. RTC Power Source

If the module is only powered by VRTC, the real time will have an error about 5 minutes a day. There are several effective ways to get reliable and accurate system time.

- **Use VBAT as the RTC power source**

When the module is turned off and the main power supply (VBAT) is remained, the real time clock is still active as the RTC core is supplied by VBAT, in this condition, the error is about 3 seconds in 48 hours. It

is recommended to keep connection with VBAT all the time if you want to get an accurate time. A reference circuit is shown as below.

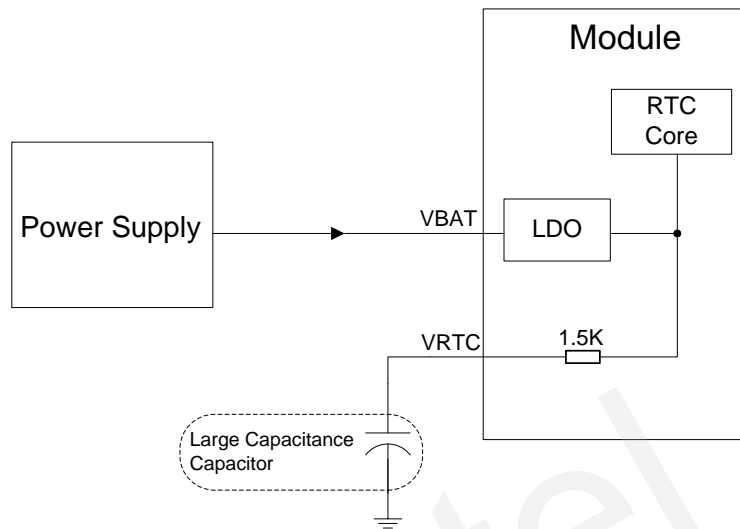

Figure 1: RTC is Supplied by VBAT

- **Use backup power as the RTC power source**

When VBAT power is switched off for a long time, a backup power such as a super-capacitor can be used to supply the VBAT pin to keep the real time clock active, the reference design for backup power is shown as below.

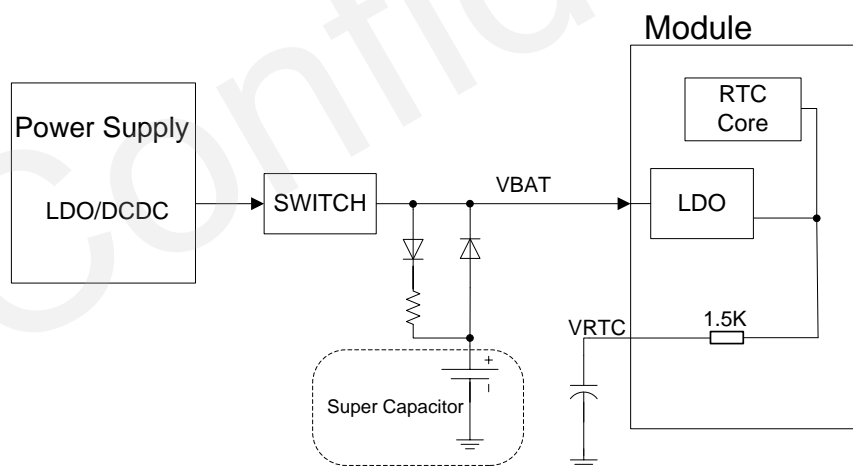

Figure 2: RTC is Supplied by a Backup Power

2.3. Time Synchronization by NITZ or NTP

In general, there are two ways to realize time synchronization.

- **NITZ (Network Identity and Time Zone)**

AT+QNITZ can be used to set the module to synchronize RTC via GSM network. **AT+CTZU** can be used to set module to update time zone via NITZ automatically. This function needs the support of local GSM network and it will not generate GPRS data traffic.

- **NTP (Network Time Protocol)**

If the local GSM network does not support NITZ, you can select NTP to get local time. The module can be set by the command **AT+QNTP** and it will generate GPRS data traffic.

Quectel
Confidential