



Antenna Datasheet

Product OC (Antenna Only): YCGS010AA

Product OC (Antenna + Rectangular EVB): YCGS010AAEVB

Version: 3.0

Date: 2025-12-22

Status: Released

Product Name: GNSS Full Band SMT Mount Ceramic Chip Passive
Embedded Antenna

Key Features:

Frequency Band: 1164–1300 MHz; 1559–1606 MHz

Dimensions: 5 mm × 3 mm × 0.5 mm

RoHS and REACH Compliant

Overview

The Quectel YCGS010AA is passive GNSS full band antenna. The product has dimensions of only 5 mm × 3 mm × 0.5 mm and weighs approximately 0.025 g. It is made of ceramic material with a white appearance and is an SMD (Surface Mount Device) type antenna. It can operate stably within the temperature range of – 40 °C to + 85 °C and complies with RoHS and REACH standards.

In terms of radio frequency parameters, it covers the frequency bands of 1164–1300 MHz and 1559–1606 MHz, has an impedance of 50 Ω, linear polarization, and an omni - directional radiation pattern. It exhibits corresponding VSWR, return loss, efficiency, and peak gain performance in different frequency bands. When installing, the SMD method is used, and it is suitable for a rectangular EVB with dimensions of 80 mm × 40 mm. The transmission line needs to be designed with a characteristic impedance of 50 Ω and should be as short as possible.

It is suitable for scenarios with high requirements for size and accuracy, can support multiple systems such as GPS, GLONASS, GALILEO, BDS, QZSS, and IRNSS, and can meet the application requirements of small mobile devices, IoT terminals, high - precision positioning products, etc.

Quectel provides comprehensive antenna design support such as simulation, testing and manufacturing for custom antenna solutions to meet your specific application needs. We have regional R & D centers to offer quick response to meet your requirements. Please contact our sales & FAEs if you have any requests.

Contents

Overview	2
Contents	3
1 Specification	4
1.1. Electrical.....	4
1.2. Mechanical & Environmental	5
1.3. Supported GNSS Frequency Bands.....	6
2 Drawing	8
2.1. Antenna	8
2.2. Rectangular EVB.....	9
3 Detailed Performance	10
3.1. S-Parameter Test	10
3.1.1. VSWR.....	10
3.1.2. Return Loss	11
3.2. Radiation Performance Test.....	12
3.2.1. Efficiency	12
3.2.2. Peak Gain.....	13
3.2.3. 3D & 2D Radiation Pattern.....	14
4 Schematic Symbol and Pin Definition	17
5 Transmission Line	18
6 Recommended PCB Layout	19
7 Matching Circuit	20
8 Soldering Temperature	21
9 Reflow Profile	22
10 Packaging	23
Contact Us	25
Legal Notices	26
Revision History	28

1 Specification

Test Condition: On 80 mm × 40 mm EVB

1.1. Electrical

Electrical	
Frequency Range	1164–1300 MHz; 1559–1606 MHz
Impedance	50 Ω
Polarization	Linear
Radiation Pattern	Omni-directional

Band	GPS L5	GALILEO E5a	GALILEO E5b	GPS L2 QZSS L2C	GLONASS G2	BDSBDS B3	BDSBDS B1I	GPS L1	GLONASS G1
	GALILEO E1							BDSBDS B1C	
Frequency (MHz)	1176	1207	1227	1248	1268	1561	1575	1602	
VSWR	1.5	1.6	2.3	3.0	3.3	1.5	1.4	1.4	
Return Loss (dB)	-13.8	-12.7	-8.0	-6.1	-5.4	-13.5	-15.7	-16.4	
Efficiency (%)	49.5	50.1	49.6	44.8	42.7	71.8	70.5	73.9	
Peak Gain (dBi)	1.3	1.0	0.6	0.3	0.0	2.1	2.0	2.2	

1.2. Mechanical & Environmental

Mechanical	
Antenna Dimensions	5 mm × 3 mm × 0.5 mm
Material & Color	Ceramic & White
Mounting Type	SMD
Weight	Typ. 0.025 g
Recommended EVB Size	Rectangular EVB: 80 mm × 40 mm
Environmental	
Operation Temperature	-40 °C to +85 °C
Storage Temperature	-40 °C to +85 °C
RoHS and REACH Compliant	Yes

1.3. Supported GNSS Frequency Bands

GNSS Frequency Bands (MHz)					
GPS	L1 Centre 1575.42 (1565–1586)	L2 Centre 1227.6 (1217–1238)	L5 Centre 1176.45 (1164–1189)		
	√	√	√		
GLONASS	G1-L10C-L10F Centre 1601 (1595–1606)	G2-L20C-L20F Centre 1248.06 (1241–1255)	G3-L30C Centre 1202.025 (1189–1213)		
	√	√	√		
GALILEO	E1 Centre 1575.42 (1563–1588)	E5a Centre 1176.45 (1166–1187)	E5b Centre 1207.14 (1197–1218)	E6 Centre 1278.75 (1258–1300)	
	√	√	√	√	
BDSBDS	B1I Centre 1561.098 (1559–1564)	B1C (BDSBDS-3) Centre 1575.42 (1559–1592)	B2a Centre 1176.45 (1166–1187)	B2b-B2I Centre 1207.14 (1197–1217)	B3 Centre 1268.52 (1258–1279)
	√	√	√	√	√
QZSS	L1 Centre 1575.42 (1573–1578)	L2C Centre 1227.6 (1226–1229)	L5 Centre 1176.45 (1166–1187)	L6 Centre 1278.75 (1257–1300)	
	√	√	√	√	
IRNSS	L5 Centre 1176.45 (1164–1189)				
	√				

GNSS Bands and Constellations



2 Drawing

2.1. Antenna

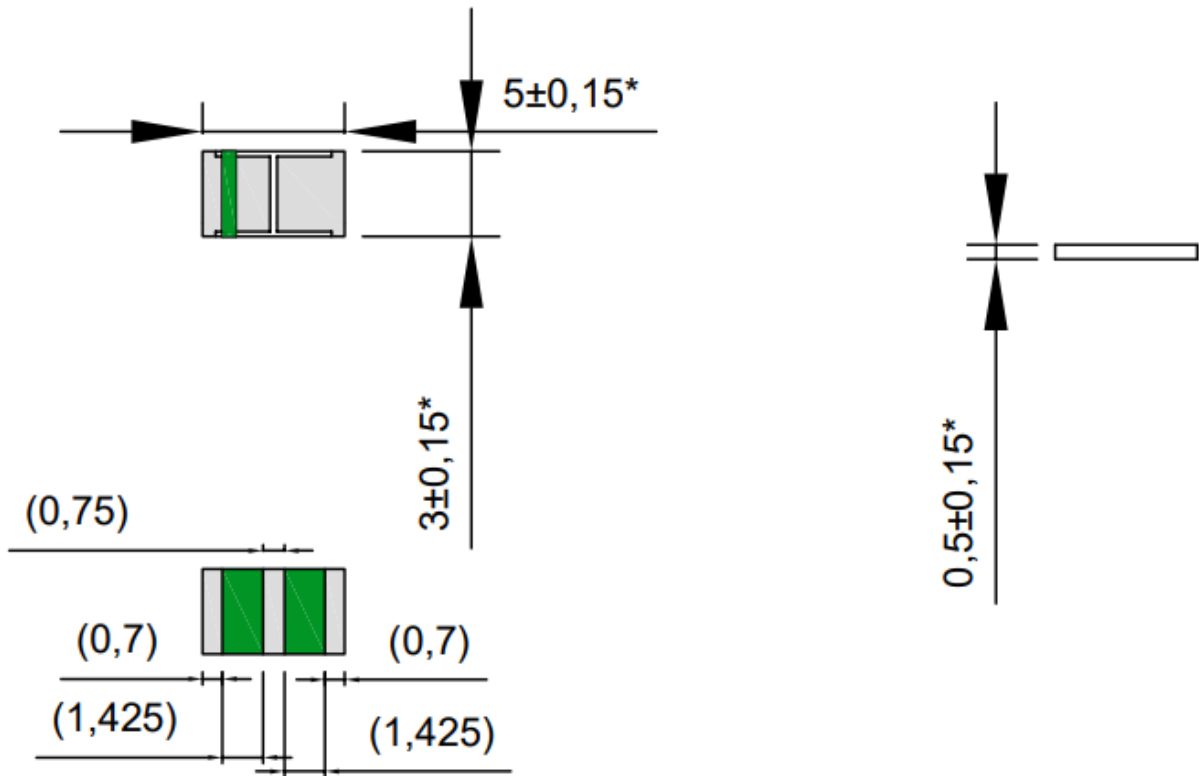

2.2. Rectangular EVB

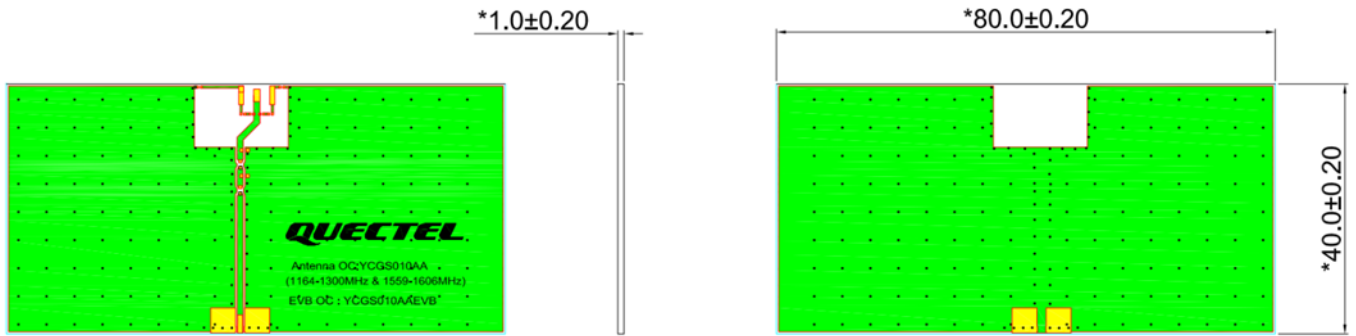

All dimensions are in mm.

3 Detailed Performance

3.1. S-Parameter Test

3.1.1. VSWR

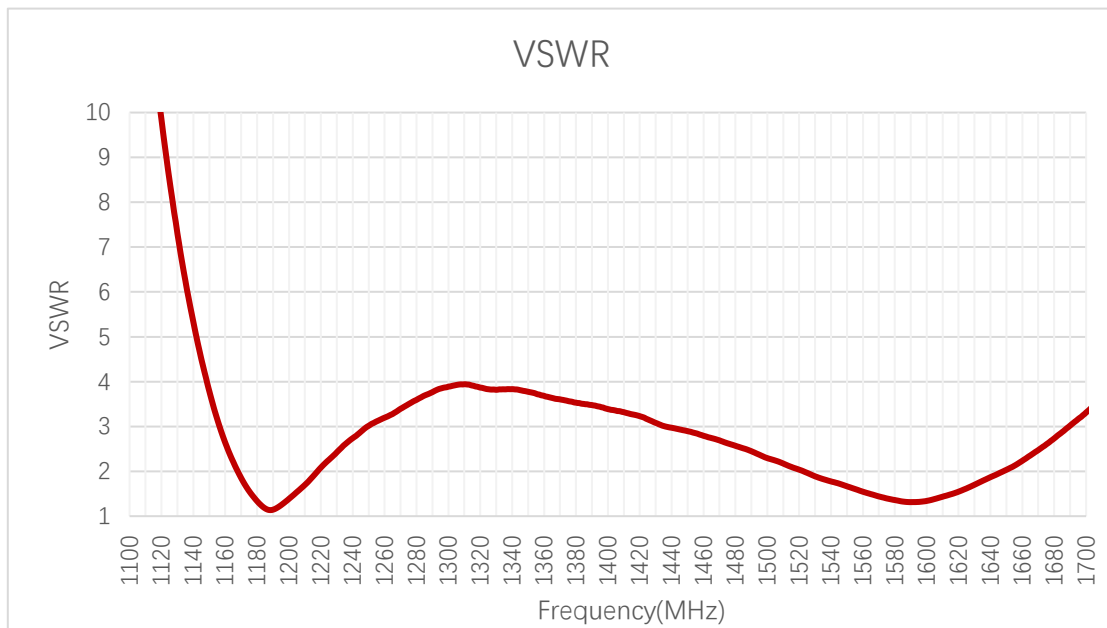

VSWR

Frequency (MHz)	1176	1207	1227	1248	1268	1561	1575	1602
VSWR	1.5	1.6	2.3	3.0	3.3	1.5	1.4	1.4

3.1.2. Return Loss

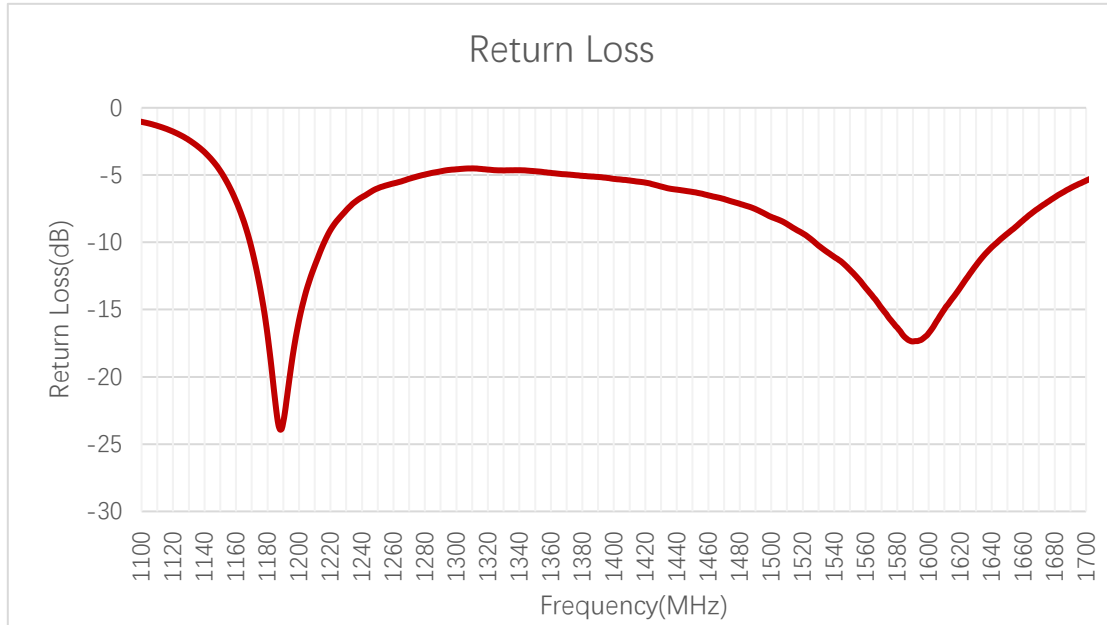

Return Loss (dB)

Frequency (MHz)	1176	1207	1227	1248	1268	1561	1575	1602
Return Loss (dB)	-13.8	-12.7	-8.0	-6.1	-5.4	-13.5	-15.7	-16.4

3.2. Radiation Performance Test

3.2.1. Efficiency

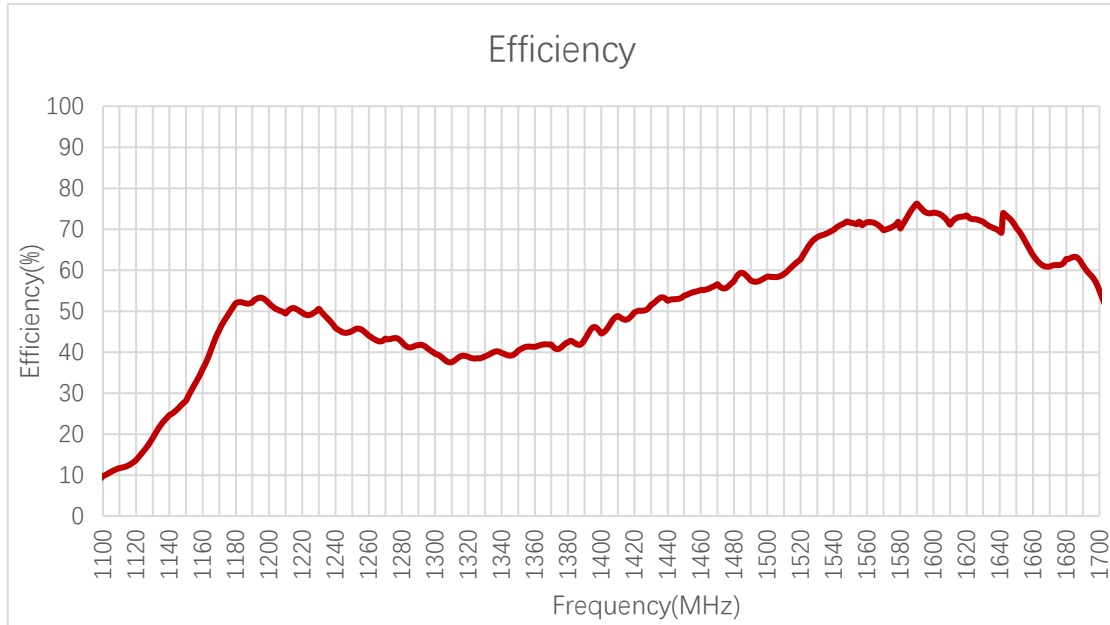

Efficiency (%)

Frequency (MHz)	1176	1207	1227	1248	1268	1561	1575	1602
Efficiency (%)	49.5	50.1	49.6	44.8	42.7	71.8	70.5	73.9

3.2.2. Peak Gain

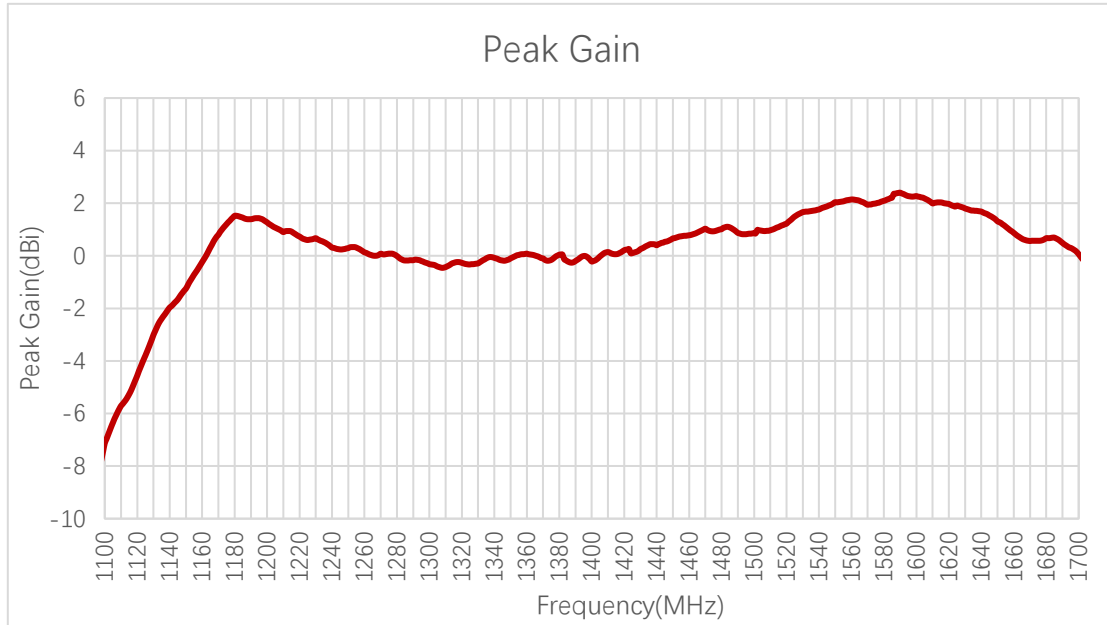

Peak Gain (dBi)

Frequency (MHz)	1176	1207	1227	1248	1268	1561	1575	1602
Peak Gain (dBi)	1.3	1.0	0.6	0.3	0.0	2.1	2.0	2.2

3.2.3. 3D & 2D Radiation Pattern

- Test Condition: on 80 mm × 40 mm EVB
- Test Chamber: GL-S-1

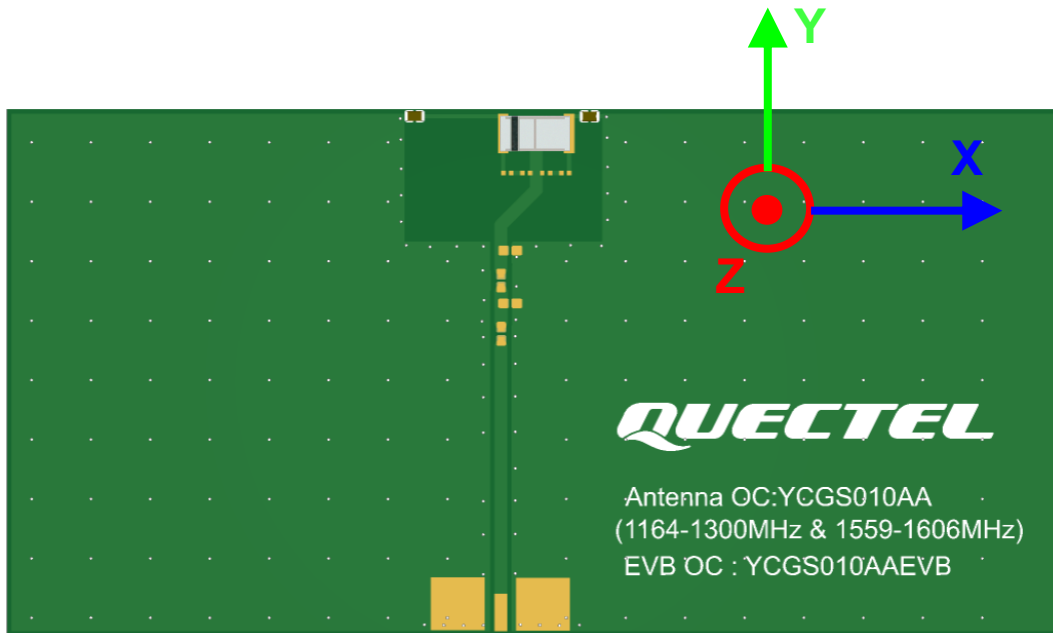

1176 MHz		1207 MHz	
----------	--	----------	--

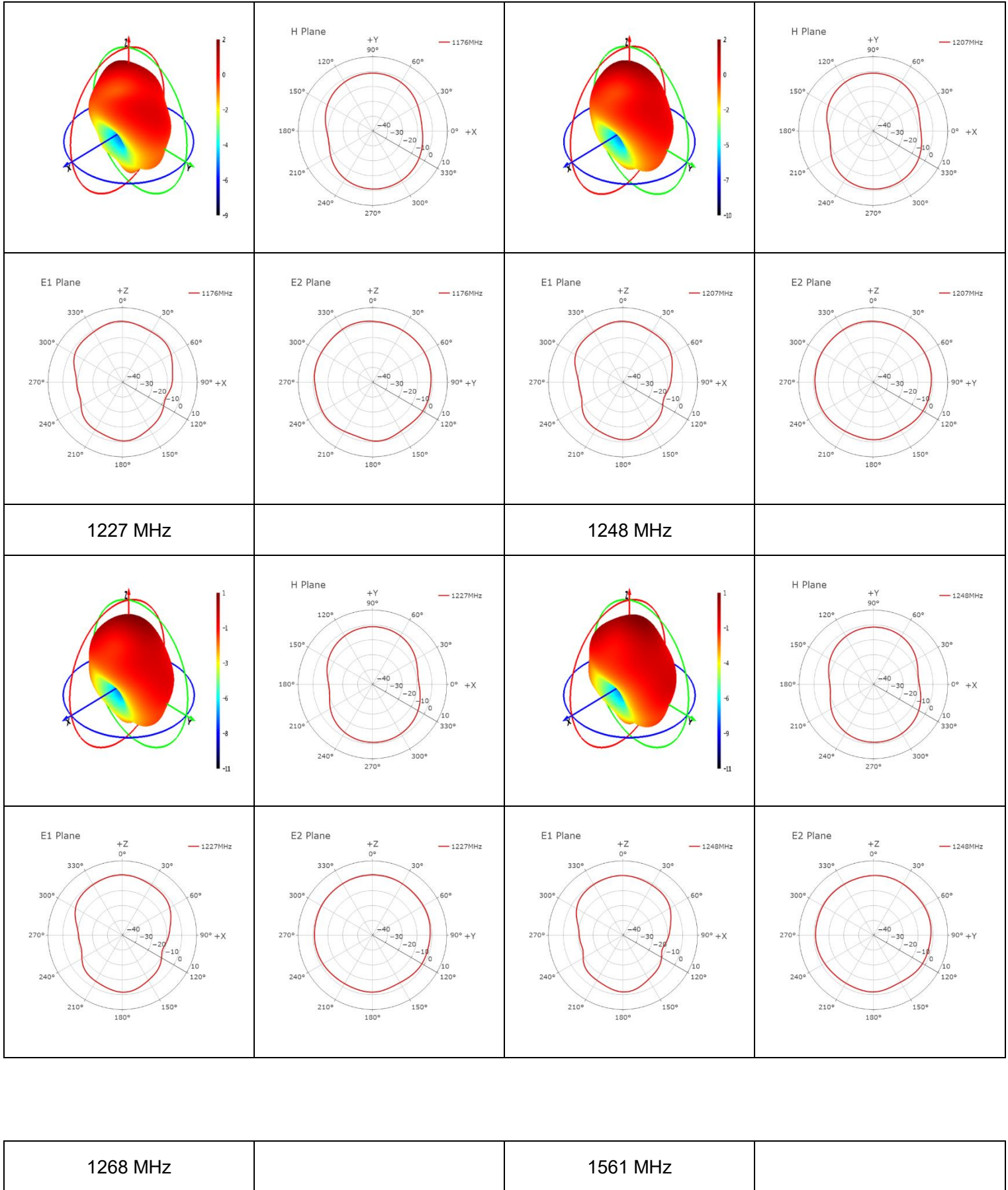

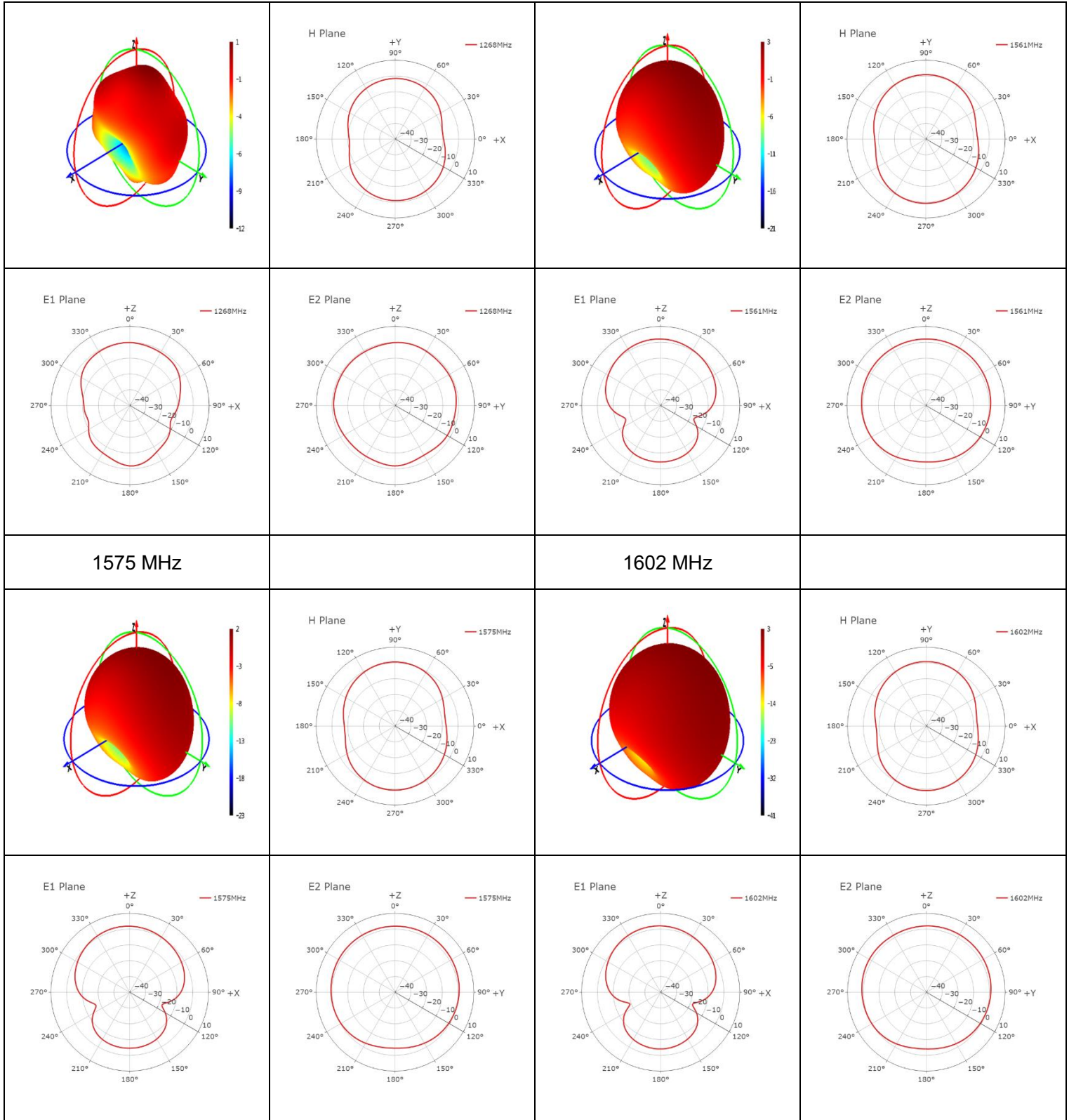

4 Schematic Symbol and Pin Definition

- The pin assignment for the antenna is as follows.
- The circuit symbol for the antenna is shown below. The antenna has 2 pins, only one of which works. All other pins are for mechanical strength.

Pin	Description
1,3	Return / GND
2	Feed

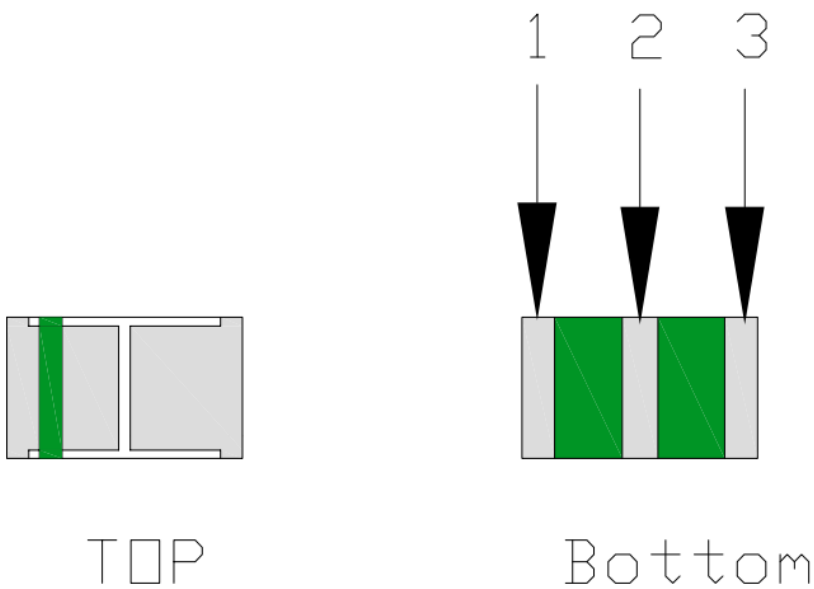

5 Transmission Line

The characteristic impedance of all transmission lines shall be designed as 50 Ω .

- The length of the transmission lines should be kept as short as possible.
- Any other part of the RF system, such as transceiver, power amplifiers, etc., shall also be designed with an impedance of 50 Ω .

Once the material for the PCB has been chosen (PCB thickness and dielectric constant), a coplanar transmission line can easily be designed using any of the commercial software packages for transmission line design. For the chosen PCB thickness, copper thickness and substrate dielectric constant, the program will calculate the appropriate transmission line width and gaps on either side of the track so the characteristic impedance of the coplanar transmission is 50 Ω .

7 Matching Circuit

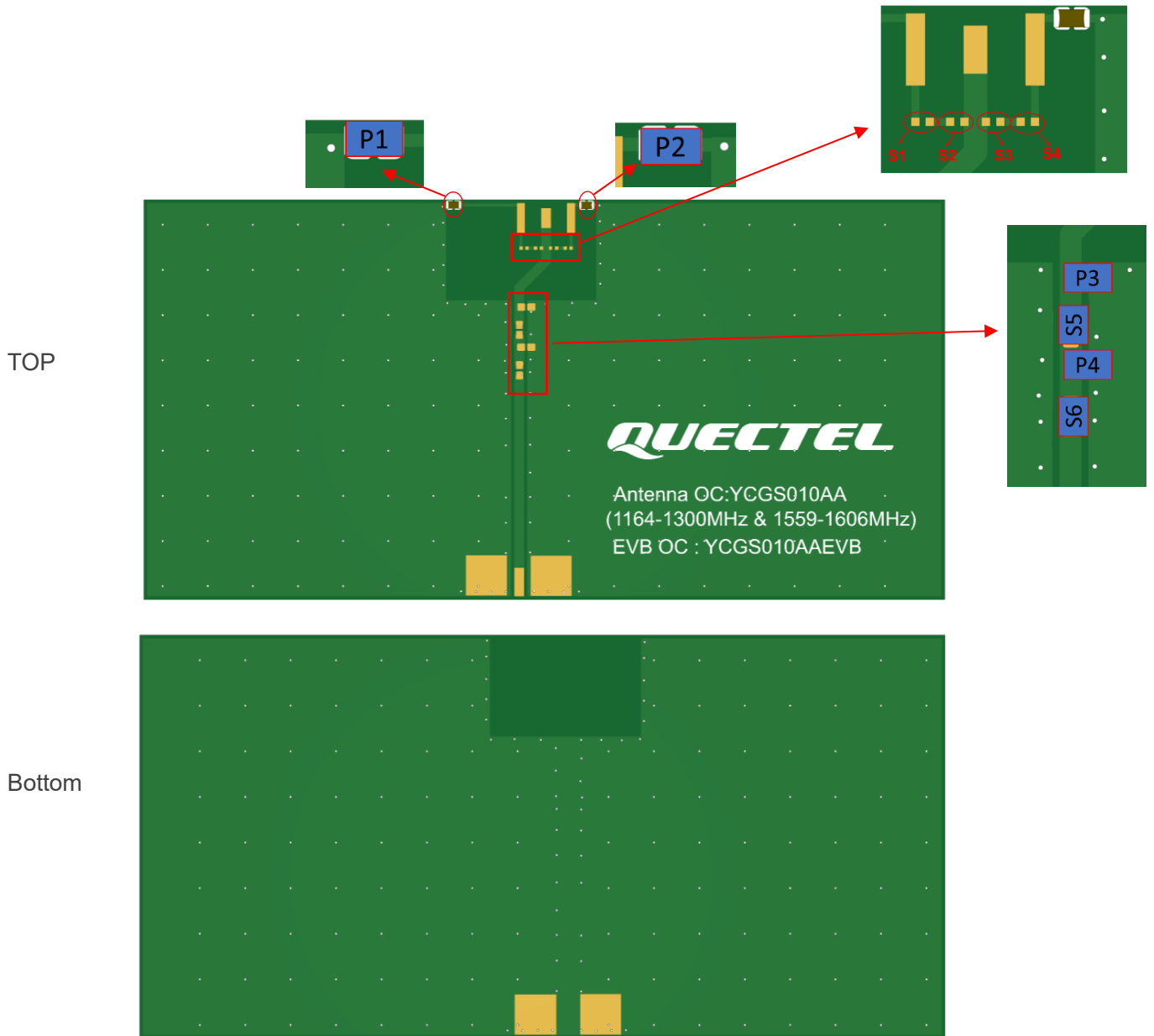

	P1	P2	P3	P4	S1-S4	S5	S6
Default Matching	6.8pF (0201)	2.7pF (0201)	1.5pF (0402)	N/A	N/A	3.6pF (0402)	0Ω (0402)
Tolerance	±0.1pF	±0.1pF	±0.05pF	-	-	±0.01pF	-

8 Soldering Temperature

Phase	Profile Features	PB-Free Assembly
RAMP-UP	Avg. Ramp-up Rate (T _{max} to T _p)	3 °C/second (Max.)
PREHEAT	Temperature Min (T _{min}) Temperature Max (T _{max}) Time (t _{min} to t _{max})	150 °C 190 °C 110 seconds (Max.)
REFLOW	Temperature (TL) Total Time above TL (tl)	220 °C 90 seconds (Max.)
PEAK	Temperature (T _p)	230–250 °C
RAMP-DOWN	Rate	-1 °C/second (Max.)

9 Reflow Profile

Typical Soldering Profile for Lead-free Process

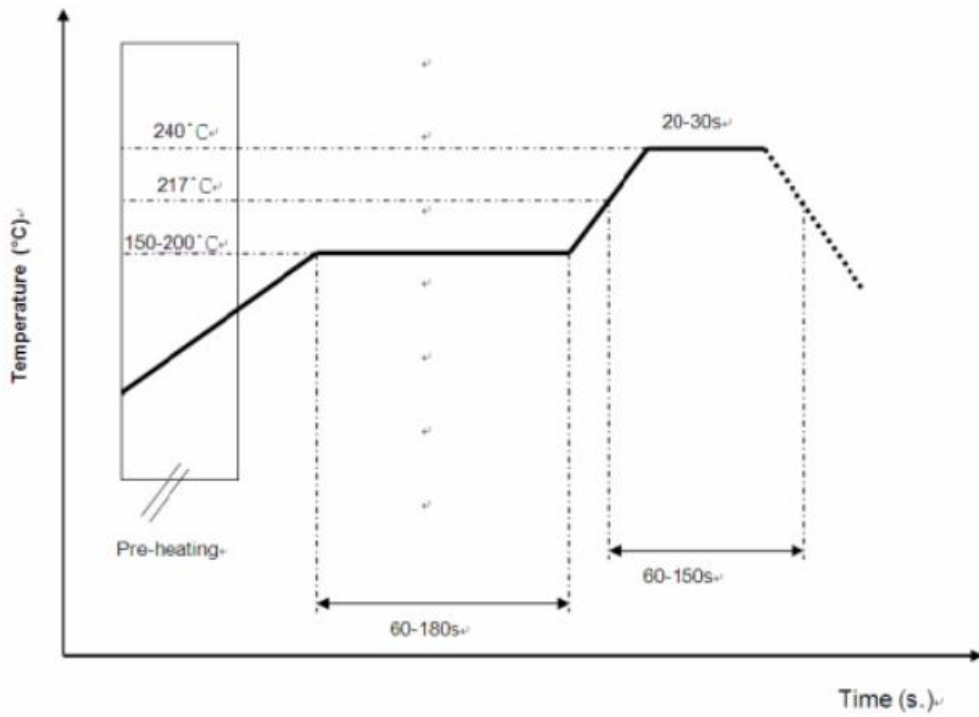

*Recommended solder paste alloy: SAC305 (Sn96.5 /Ag3 /Cu0.5) Lead Free solder paste.

10 Packaging

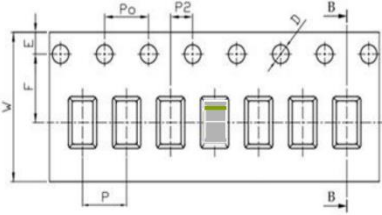
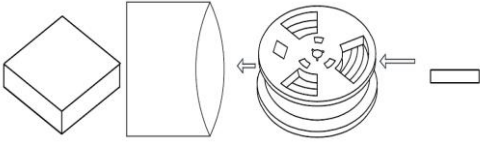
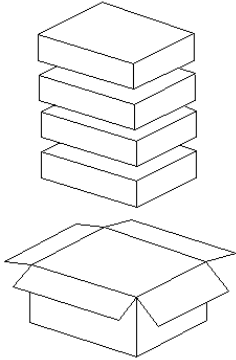
Step	Packaging Picture/2D Picture	Description
1		Reel
2		<p>(6000 Antenna Products / Reel) 2 Reel tape is vacuumed into the inner box.</p>
3		<p>(4 Inner Boxes / Carton Box) (48000 Antennas / Carton Box) Estimated quantity Products that cannot fill the entire carton box are packed in a suitable size carton box. <u>Carton Size:</u> <u>L x W x H = 370 x 370 x 295 mm</u></p>

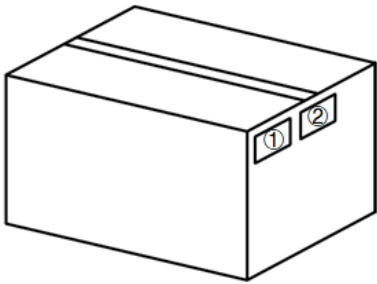
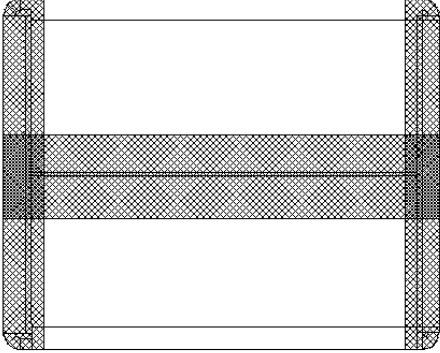
4		<p>Position for Attaching Labels</p> <ul style="list-style-type: none"> ① Carton Label ② Quality Label
5		<p>Sealing Cartons H-shaped sealing cartons</p>
Note	<p>The initial packaging method described above is for reference only, and the final actual packaging method shall be subject to the actual shipping packaging.</p>	

Contact Us

At Quectel, our aim is to provide timely and comprehensive services to our customers. If you require any assistance, please contact our headquarters:

Quectel Wireless Solutions Co., Ltd.

No. 8 Waipojing Road, Sijing Town, Songjiang District, Shanghai 201601, China

Tel: +86 21 5108 6236

Email: info@quectel.com

Or our local offices. For more information, please visit:

<https://www.quectel.com/contact/>.

For technical support, or to report documentation errors, please visit:

<https://www.quectel.com/tech-support/>.

Or email us at: support@quectel.com.

Legal Notices

We provide this document to support your product design. You are required to design your products based on the specifications and parameters set forth herein. You agree that you are responsible for using independent analysis and evaluation in designing intended products, and we provide reference designs for illustrative purposes only. Before using any hardware, software or service guided by this document, please read this notice carefully. Even though we employ commercially reasonable efforts to provide the best possible experience, you hereby acknowledge and agree that this document and related services hereunder are provided to you on an “as available” basis. You acknowledge and agree that we may add to, amend, or restate this document at any time at our sole discretion without any prior notice to you, and such additions, amendments, or restatements shall be binding upon you.

Use and Disclosure Restrictions

License Agreements

The recipient of any hardware, software, materials, or documentation provided by us shall keep such content confidential, unless expressly authorized by us. The recipient shall not disclose, access, or use any part of the received content for any purpose other than the execution and implementation of the intended project.

Copyright

Our and third-party products hereunder may contain copyrighted materials, including but not limited to protected content, hardware, software, and documentation owned by us or applicable third parties. Unless prior written consent is obtained, you shall not access, use, or disclose any documents or information provided by us, nor shall you copy, reproduce, republish, display, translate, distribute, merge, modify, or create derivative works from any such copyrighted materials. We and the applicable third party retain exclusive rights to all copyrighted materials. No license to any patents, copyrights, trademarks, or service marks shall be granted or transferred. For the avoidance of doubt, no form of purchase shall be construed as granting any license beyond a normal, non-exclusive, royalty-free license to use the product. We reserve the right to pursue legal action against any violation of confidentiality obligations, unauthorized use, or any other unlawful or malicious use of the aforementioned documents and information.

Trademarks

Unless otherwise expressly provided, nothing in this document shall be construed as conferring any rights to use any trademark, trade name, name, abbreviation, or counterfeit thereof owned by us or any third party in advertising, publicity, or any other contexts.

Third-Party Rights

You understand that this document may refer to hardware, software, and/or documentation owned by one or more third parties (“third-party materials”). Use of such third-party materials is subject to all applicable restrictions and obligations set forth herein.

We make no warranty or representation, either express or implied, regarding the third-party materials, including but not limited to any implied or statutory, warranties of merchantability or fitness for a particular purpose, quiet enjoyment, system integration, information accuracy, and non-infringement of any third-party intellectual property rights with regard to the licensed technology or use thereof. Nothing herein constitutes a representation or warranty by us to either develop, enhance, modify, distribute, market, sell, offer for sale, or otherwise maintain production of any our products or any other hardware, software, device, tool, information, or product. We moreover disclaim any and all warranties arising from the course of dealing, course of performance, or usage of trade.

Privacy Policy

To enable product functionality, certain device data may be uploaded to our or third-party servers, including those operated by carriers, chipset suppliers, or servers designated by you. We strictly comply with applicable laws and regulations and will retain, use, disclose, or otherwise process relevant data solely for the purpose of enabling product functionality, or as permitted by applicable laws. Before interacting with any third party regarding data exchange, please be informed of and understand their privacy and data security policies.

Disclaimer

- a) We shall not be liable for any damages resulting from failure to comply with applicable operational or design specifications.
- b) We shall bear no liability for any inaccuracies or omissions in this document, nor for any damages arising from the use of the information contained herein.
- c) While we make every effort to ensure the integrity, accuracy, and timeliness of the features and functions under development, errors or omissions may nevertheless occur. Unless otherwise provided in a valid written agreement, we make no warranties of any kind, express, implied, or statutory, and disclaim all liability for any loss or damage arising from the use of any features or functions under development, to the maximum extent permitted by law, regardless of whether such loss or damage is foreseeable.
- d) We assume no legal responsibility for the accessibility, safety, accuracy, availability, legality, or completeness of any information, content, advertising, commercial offers, products, services, or materials on third-party websites or third-party resources.

Copyright © Quectel Wireless Solutions Co., Ltd. 2025. All rights reserved.

Revision History

Version	Date	Author	Note
-	2022-05-27	Junsen Li/ Joye Wang	Creation of the document
1.0	2022-05-27	Junsen Li/ Joye Wang	First official release
1.1	2022-09-20	Junsen Li	Added Chapter 7.
2.0	2024-04-18	Mayes Li / Lucky Feng/ David Liu/ Aria Chu	Numerous changes were made to this document. It should be read in its entirety.
2.1	2024-10-15	Xiaodong Yang	Updated antenna band (Cover page and Chapter 1.1 & 1.3)
2.2	2024-11-01	Mayes Li	Updated default matching resistance value for S6 (Chapter 7).
3.0	2025-12-22	Rhone Wei/ Lucky Feng/ Rainey Liao	<ol style="list-style-type: none">1. Updated the overview.2. Updated the EVB drawings (Cover page, Chapters 2.2, 3.2.3, 6 and 7).

QUECTEL

www.quectel.com