

# Antenna Datasheet

**Product OC:** YEMD301L1A

**Version:** 2.2

**Date:** 2025-10-14

**Status:** Released

**Product Name:** 4G & GNSS 3in1 Multiple Mount Combo External Antenna

**Key Features:**

Frequency Band: 4G: 600–960 MHz, 1710–2690 MHz;

GNSS: 1559–1606 MHz

Dimensions: 109.28 mm × 89 mm × 25.8 mm

Efficiency: Up to 77 %

GNSS LNA Gain: 18 ±3 dB

RoHS & REACH & POPS Compliant

IP67

# Overview

YEMD301L1A is a 4G & GNSS 3in1 combo antenna measuring 109.28 mm × 89 mm × 25.8 mm. This ultra-wide-band 4G & GNSS antenna provides broad coverage from 1559–1606 MHz, 600–960 MHz, 1710–2690 MHz whilst offering backward-compatibility to support 3G and 2G networks as well as LTE Cat-M and narrowband IoT (NB-IoT). Ideal for applications where the antenna is required to be discrete, the antenna is available magnet & adhesive & screw mount omni-directional antenna. It is easy to install with maximum durability assured and suitable for use in harsh outdoor environments thanks to its IP67 rated, UV-resistant and UL 94 V-0 Flame Rating enclosure. It is compatible with Quectel's RM520x Series modules.

YEMD301L1A has 2 × 4G LMH antennas and 1 × GNSS L1 antenna. It allows high efficiency, stable signal transmission and reception for active GNSS from 1559–1606 MHz, and 4G bands from 600–960 MHz, 1710–2690 MHz. In the meantime, this product also offers high isolation between antennas to avoid self-interference. All in all, this unique product is designed to provide stable and high-speed data connection to 4G & GNSS applications. YEMD301L1A can be used in harsh environments thanks to its robust UV resistant (UL 746c f1) and flame resistant (UL 94 V-0) enclosure.

Typical applications include:

- Public safety
- HD Video Streaming
- Utilities and Smart Cities
- Fleet Management
- Automotive vehicle tracking

Quectel provides comprehensive antenna design support such as simulation, testing and manufacturing for custom antenna solutions to meet your specific application needs. We have regional R & D centers to offer quick response to meet your requirements. Please contact our sales & FAEs if you have any requests.

# Contents

<b>Overview</b> .....	<b>1</b>
<b>Contents</b> .....	<b>2</b>
<b>1 Specification</b> .....	<b>3</b>
1.1. Electrical.....	3
1.1.1. LTE-1.....	4
1.1.2. LTE-2.....	5
1.1.3. GNSS.....	6
1.2. Mechanical & Environmental.....	7
1.3. Block Diagram (Active Antenna).....	8
1.4. Supported GNSS Frequency Bands.....	9
<b>2 Drawing</b> .....	<b>11</b>
<b>3 Detailed Performance</b> .....	<b>12</b>
3.1. S-Parameter Test.....	12
3.1.1. VSWR.....	12
3.1.2. Return Loss.....	14
3.1.3. Isolation.....	16
3.1.4. GNSS LNA Gain.....	17
3.1.5. GNSS Noise Figure.....	18
3.2. Radiation Performance Test.....	19
3.2.1. Efficiency.....	19
3.2.2. Average Gain.....	21
3.2.3. Peak Gain.....	22
3.2.4. 3D & 2D Radiation Pattern.....	24
3.2.5. 3D & 2D Radiation Pattern.....	32
<b>4 Installation</b> .....	<b>39</b>
<b>5 Packaging</b> .....	<b>41</b>
<b>Contact Us</b> .....	<b>43</b>
<b>Legal Notices</b> .....	<b>44</b>
<b>Revision History</b> .....	<b>46</b>

# 1 Specification

Test Condition: Free Space & On 300 mm × 300 mm Metal Plane

## 1.1. Electrical

Electrical Specifications			
Frequency Range	LTE-1	600–960 MHz, 1710–2690 MHz	
	LTE-2	600–960 MHz, 1710–2690 MHz	
	GNSS	1559–1606 MHz	
Radiation Pattern	LTE-1	Omni-directional	
	LTE-2	Omni-directional	
	GNSS	Directional	
Polarization	LTE-1	Linear	
	LTE-2	Linear	
	GNSS	RHCP	
Impedance		50 Ω	
Isolation	LTE-1-LTE-2	FS	≤ -14.9 dB
		MP	≤ -13.4 dB

### 1.1.1. LTE-1

Electrical – Detail												
SPEC	Band	B71	B12 /B13 /B28	B5 /B8 /B26	n74 /n75 /n76	B1 /B2 /B3	B40	Wi-Fi 2G	B38 /B41	B42 /B48 /n77	n79	Wi-Fi 5G
	Freq. (MHz)	600–700	700–810	820–960	1420–1520	1700–2170	2300–2400	2400–2500	2500–2690	3300–4200	4400–5000	5150–5850
Max. VSWR	FS	4.2	3.5	4.9		1.8	2.1	3.2	3.5	-	-	-
	MP	4.1	2.5	6.2		2.4	2.0	2.0	3.7	-	-	-
Max. Return Loss (dB)	FS	-4.2	-5.1	-3.6	-	-10.5	-8.8	-5.7	-5.2	-	-	-
	MP	-4.4	-7.2	-2.8	-	-7.6	-9.7	-9.5	-4.8	-	-	-
AVG Eff. (%)	FS	32.3	53.9	46.5	-	57.4	46.0	34.2	27.1	-	-	-
	MP	34.5	58.8	36.1	-	48.8	35.8	35.2	30.2	-	-	-
AVG AVG Gain (dB)	FS	-5.0	-2.7	-3.5	-	-2.4	-3.4	-4.7	-5.7	-	-	-
	MP	-5.0	-2.3	-4.6	-	-3.2	-4.5	-4.5	-5.3	-	-	-
Max. Peak Gain (dBi)	FS	2.3	2.2	2.3	-	3.9	1.4	0.1	0.1	-	-	-
	MP	1.6	2.2	2.7	-	5.6	2.4	2.5	2.3	-	-	-
VSWR	FS					≤ 4.9						
	MP					≤ 6.2						
Return Loss	FS					≤ -3.6 dB						
	MP					≤ -2.8 dB						
Gain	FS					≤ 3.9 dBi						
	MP					≤ 5.6 dBi						

- FS: Free Space
- MP: On 300 mm × 300 mm Metal Plane

### 1.1.2. LTE-2

Electrical – Detail												
SPEC	Band	B71	B12 /B13 /B28	B5 /B8 /B26	n74 /n75 /n76	B1 /B2 /B3	B40	Wi-Fi 2G	B38 /B41	B42 /B48 /n77	n79	Wi-Fi 5G
	Freq. (MHz)	600– 700	700– 810	820– 960	1420– 1520	1700– 2170	2300– 2400	2400– 2500	2500– 2690	3300– 4200	4400– 5000	5150– 5850
Max. VSWR	FS	4.7	3.3	4.5	-	1.8	2.3	3.1	3.6	-	-	-
	MP	3.2	2.5	5.6	-	2.0	2.3	2.1	3.5	-	-	-
Max. Return Loss (dB)	FS	-3.8	-5.4	-3.9	-	-11.1	-7.9	-5.7	-5.0	-	-	-
	MP	-5.5	-7.4	-3.2	-	-9.3	-8.3	-9.2	-5.2	-	-	-
AVG Eff. (%)	FS	33.8	62.2	43.1	-	57.1	47.0	35.7	32.4	-	-	-
	MP	28.4	53.4	46.9	-	55.0	37.1	37.4	35.9	-	-	-
AVG AVG Gain (dB)	FS	-5.2	-2.1	-4.0	-	-2.4	-3.3	-4.5	-4.9	-	-	-
	MP	-5.5	-3.1	-3.8	-	-2.6	-4.3	-4.3	-4.5	-	-	-
Max. Peak Gain (dBi)	FS	5.3	5.3	2.0	-	5.2	2.0	1.0	0.4	-	-	-
	MP	1.1	4.6	4.5	-	4.6	2.3	3.7	3.8	-	-	-
VSWR	FS											≤ 4.7
	MP											≤ 5.6
Return Loss	FS											≤ -3.8 dB
	MP											≤ -3.2 dB
Gain	FS											≤ 5.3 dBi
	MP											≤ 4.6 dBi

- FS: Free Space
- MP: On 300 mm × 300 mm Metal Plane

### 1.1.3. GNSS

Band  Frequency (MHz)	GPS L5 GALILEO E5a BDS B2a- B2I QZSS L5 IRNSS L5	GALILEO E5b BDS B2b	GPS L2 QZSS L2C	GLONASS G2	BDS B3	BDS B1I	GPS L1 GALILEO E1 BDS B1C QZSS L1	GLONASS G1
	1176	1207	1227	1248	1268	1561	1575	1602
VSWR	-	-	-	-	-	4.73	1.63	1.54
Return Loss (dB)	-	-	-	-	-	-3.7	-12.3	-13.2
Efficiency (%)	-	-	-	-	-	42	79	76
Peak Gain (dBi)	-	-	-	-	-	-0.91	1.95	2.18

LNA Electrical	
LNA Gain	18 ±3 dB @ 3V 17 ±3 dB @ 1.8V
Noise Figure	≤ 2.5 dB
Output VSWR	< 2.0
Input VSWR	< 2.0
Filter Out-of-Band Attenuation	60 dB f0 ±100 MHz f0 (1580 MHz)
Working Voltage	1.8–3.3 V
Working Current	8.3 ±2 mA
Impedance	50 Ω

## 1.2. Mechanical & Environmental

Mechanical		
<b>Antenna Dimensions</b>		109.28 mm × 89 mm × 25.8 mm
<b>Antenna Material &amp; Color</b>		PC & Black
<b>Cable Type &amp; Color &amp; Length</b>	<b>LTE-1</b>	ALS302 & Black & 1025 ±25 mm
	<b>LTE-2</b>	ALS302 & Black & 1025 ±25 mm
	<b>GNSS</b>	RG174 & Black & 1025 ±25 mm
<b>Connector Type</b>	<b>LTE-1</b>	SMA Male (The current state of the SMA connector is not waterproof. If a waterproof connector is required, it can be customized.)
	<b>LTE-2</b>	SMA Male (The current state of the SMA connector is not waterproof. If a waterproof connector is required, it can be customized.)
	<b>GNSS</b>	SMA Male (The current state of the SMA connector is not waterproof. If a waterproof connector is required, it can be customized.)
<b>Weight</b>		Typ. 145 g
<b>Mounting Type</b>		Magnet & Adhesive & Screw
Environmental		
<b>Storage Temperature</b>		-40 °C to +85 °C
<b>Operation Temperature</b>		-40 °C to +85 °C
<b>Ingress Protection (IP) Rating</b>		IP67
<b>RoHS &amp; REACH &amp; POPS Compliant</b>		Yes
<b>Housing Flame Rating</b>		UL 94 V-0
<b>Housing UV Resistant</b>		UL 746c f1

### 1.3. Block Diagram (Active Antenna)

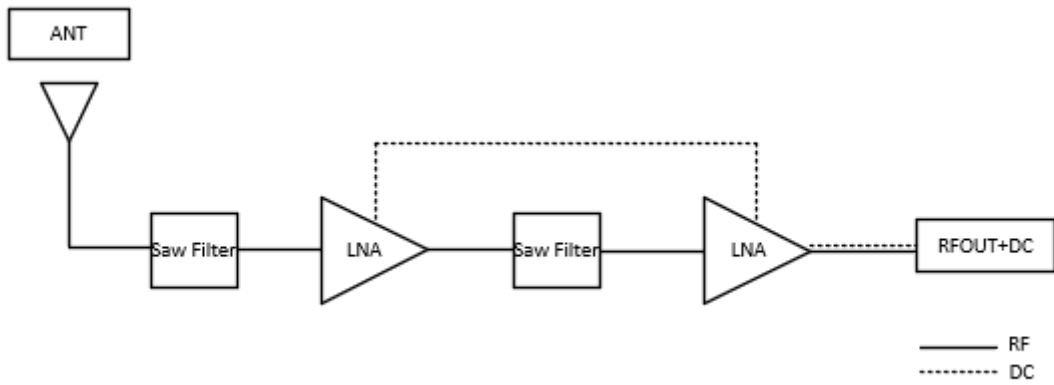

## 1.4. Supported GNSS Frequency Bands

GNSS Frequency Bands (MHz)					
<b>GPS</b>	<b>L1</b> Centre 1575.42 (1565–1586)	<b>L2</b> Centre 1227.6 (1217–1238)	<b>L5</b> Centre 1176.45 (1164–1189)		
	√	-	-		
<b>GLONASS</b>	<b>G1-L10C-L10F</b> Centre 1601 (1595–1606)	<b>G2-L20C-L20F</b> Centre 1248.06 (1241–1255)	<b>G3-L30C</b> Centre 1202.025 (1189–1213)		
	√	-	-		
<b>GALILEO</b>	<b>E1</b> Centre 1575.42 (1563–1588)	<b>E5a</b> Centre 1176.45 (1166–1187)	<b>E5b</b> Centre 1207.14 (1197–1218)	<b>E6</b> Centre 1278.75 (1258–1300)	
	√	-	-	-	
<b>BDS</b>	<b>B1I</b> Centre 1561.098 (1559–1564)	<b>B1C (BDS-3)</b> Centre 1575.42 (1559–1592)	<b>B2a-B2I</b> Centre 1176.45 (1166–1187)	<b>B2b</b> Centre 1207.14 (1197–1217)	<b>B3</b> Centre 1268.52 (1258–1279)
	√	√	-	-	-
<b>QZSS</b>	<b>L1</b> Centre 1575.42 (1573–1578)	<b>L2C</b> Centre 1227.6 (1226–1229)	<b>L5</b> Centre 1176.45 (1166–1187)	<b>L6</b> Centre 1278.75 (1257–1300)	
	√	-	-	-	
<b>IRNSS</b>	<b>L5</b> Centre 1176.45 (1164–1189)				
	-				

### GNSS Bands and Constellations

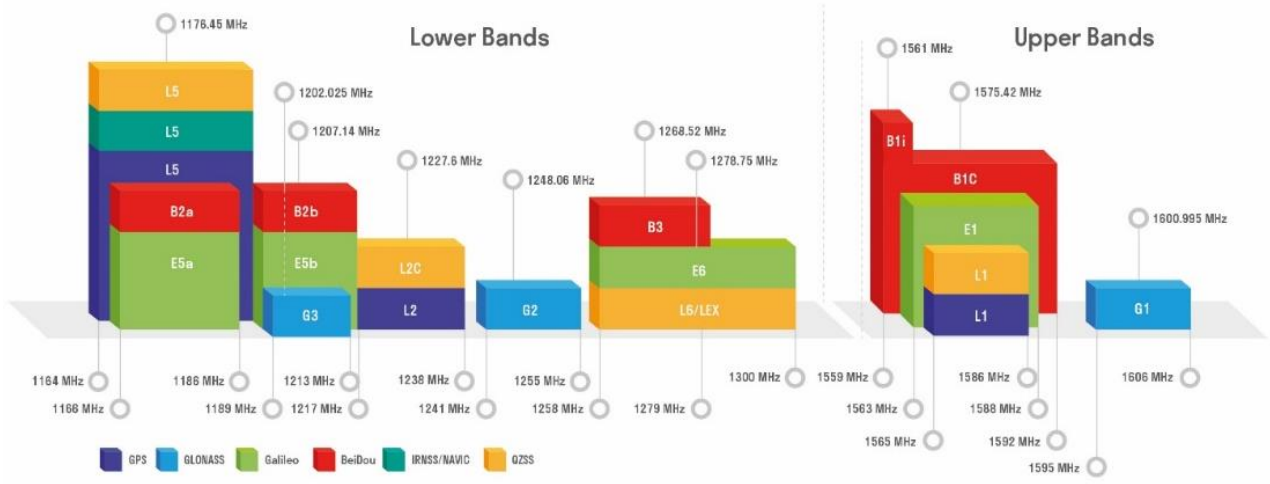

# 2 Drawing

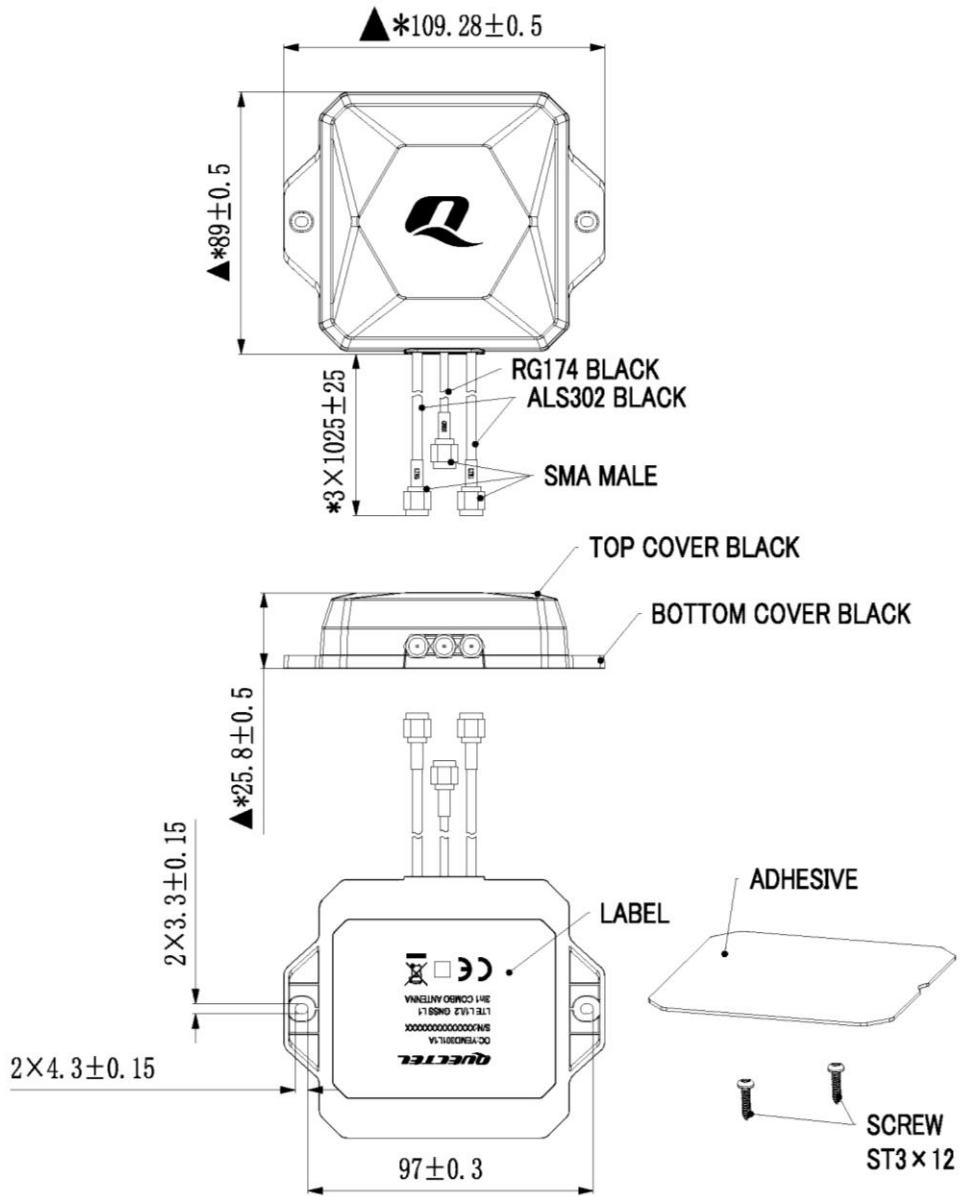

# 3 Detailed Performance

## 3.1. S-Parameter Test

### 3.1.1. VSWR

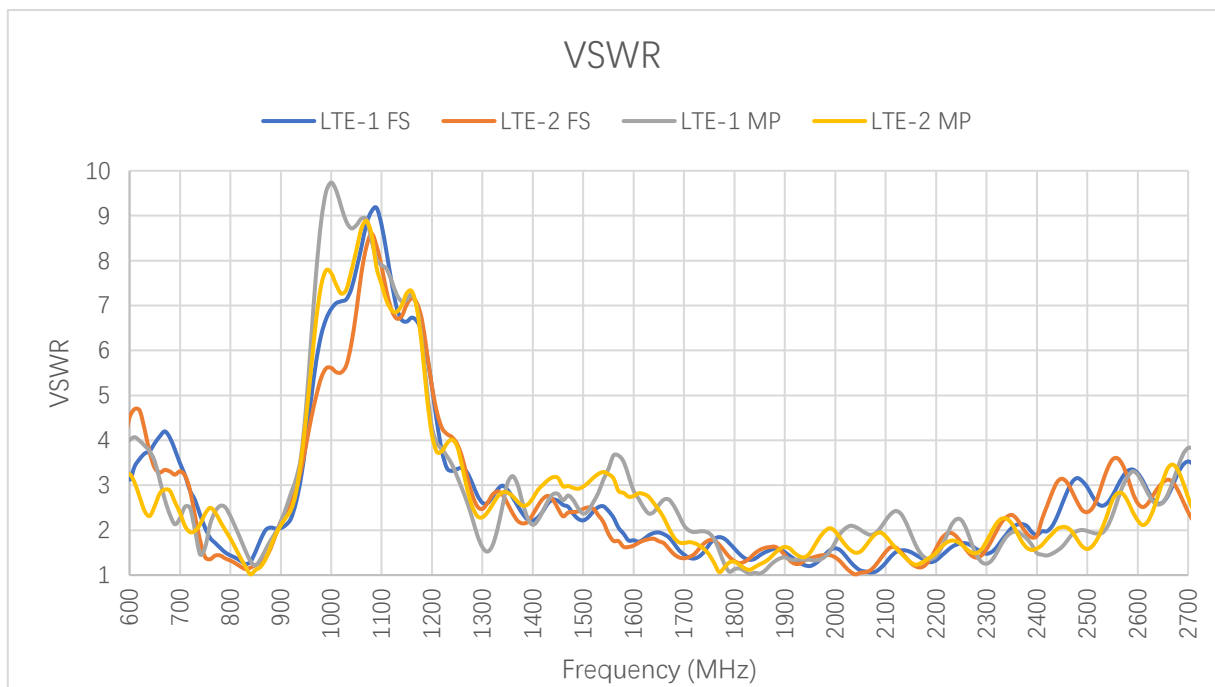

**VSWR – LTE**

Frequency (MHz)		600	630	710	830	900	960	1440	1710	1740	1880
LTE-1	FS	3.1	3.7	3.2	1.2	2.0	4.9	2.7	1.4	1.5	1.6
	MP	4.0	3.9	2.5	1.5	2.2	6.2	2.8	2.0	2.0	1.3
LTE-2	FS	4.5	4.2	3.2	1.1	2.2	4.5	2.7	1.4	1.7	1.6
	MP	3.2	2.4	2.1	1.2	2.1	5.6	3.2	1.7	1.6	1.5

Frequency (MHz)		1950	2140	2350	2450	2600	2690	4700	5000	5500	6000
LTE-1	FS	1.2	1.5	2.1	2.6	3.3	3.5	-	-	-	-
	MP	1.3	2.2	1.9	1.6	3.2	3.7	-	-	-	-
LTE-2	FS	1.4	1.4	2.3	3.1	2.6	2.6	-	-	-	-
	MP	1.5	1.4	2.1	2.1	2.2	3.1	-	-	-	-

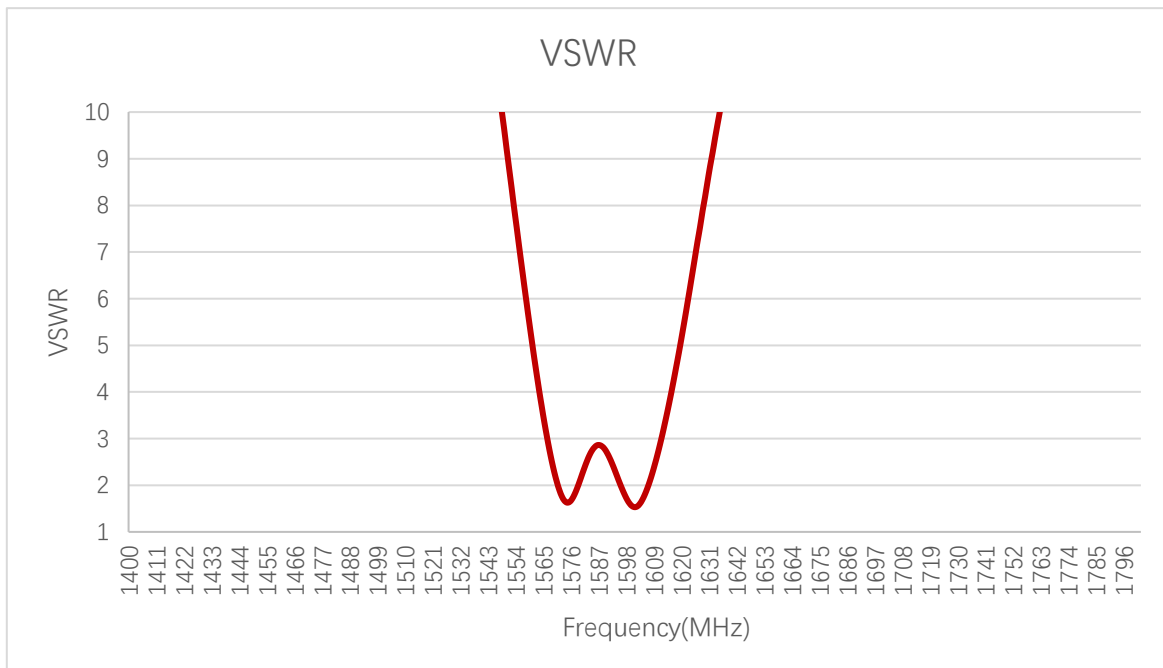

**VSWR – GNSS**

Frequency (MHz)	1176	1207	1227	1248	1268	1561	1575	1602
VSWR	-	-	-	-	-	4.73	1.63	1.54

**3.1.2. Return Loss**

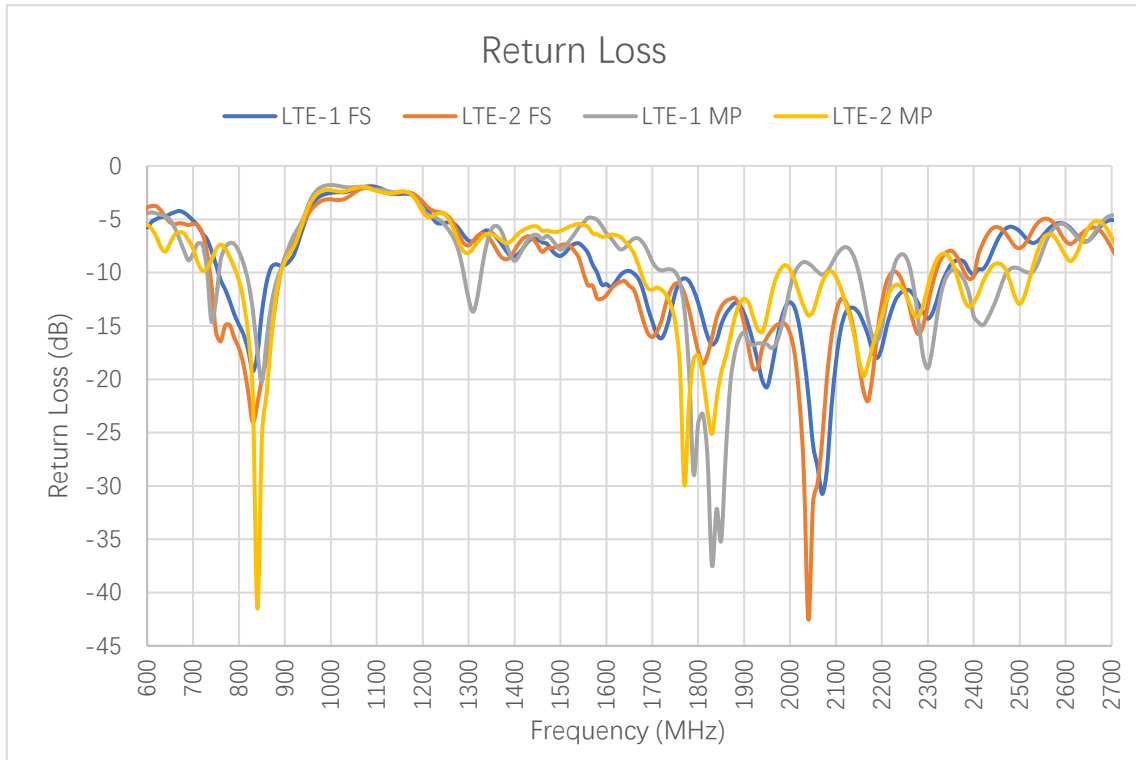

**Return Loss (dB) – LTE**

Frequency (MHz)		600	630	710	830	900	960	1440	1710	1740	1880
LTE-1	FS	-5.8	-4.8	-5.6	-19.2	-9.3	-3.6	-6.8	-15.8	-13.7	-12.9
	MP	-4.4	-4.6	-7.3	-13.5	-8.6	-2.8	-6.5	-9.6	-9.7	-17.5
LTE-2	FS	-3.9	-4.2	-5.6	-24.0	-8.6	-3.9	-6.8	-15.5	-11.7	-12.4
	MP	-5.5	-7.6	-9.0	-21.3	-9.0	-3.2	-5.7	-11.4	-13.0	-14.1
Frequency (MHz)		1950	2140	2350	2450	2600	2690	4700	5000	5500	6000
LTE-1	FS	-20.7	-13.3	-9.3	-7.1	-5.5	-5.2	-	-	-	-
	MP	-16.7	-8.6	-9.8	-12.4	-5.6	-4.8	-	-	-	-
LTE-2	FS	-16.1	-15.7	-7.9	-5.7	-7.0	-6.9	-	-	-	-
	MP	-14.0	-15.9	-8.8	-9.2	-8.4	-5.9	-	-	-	-

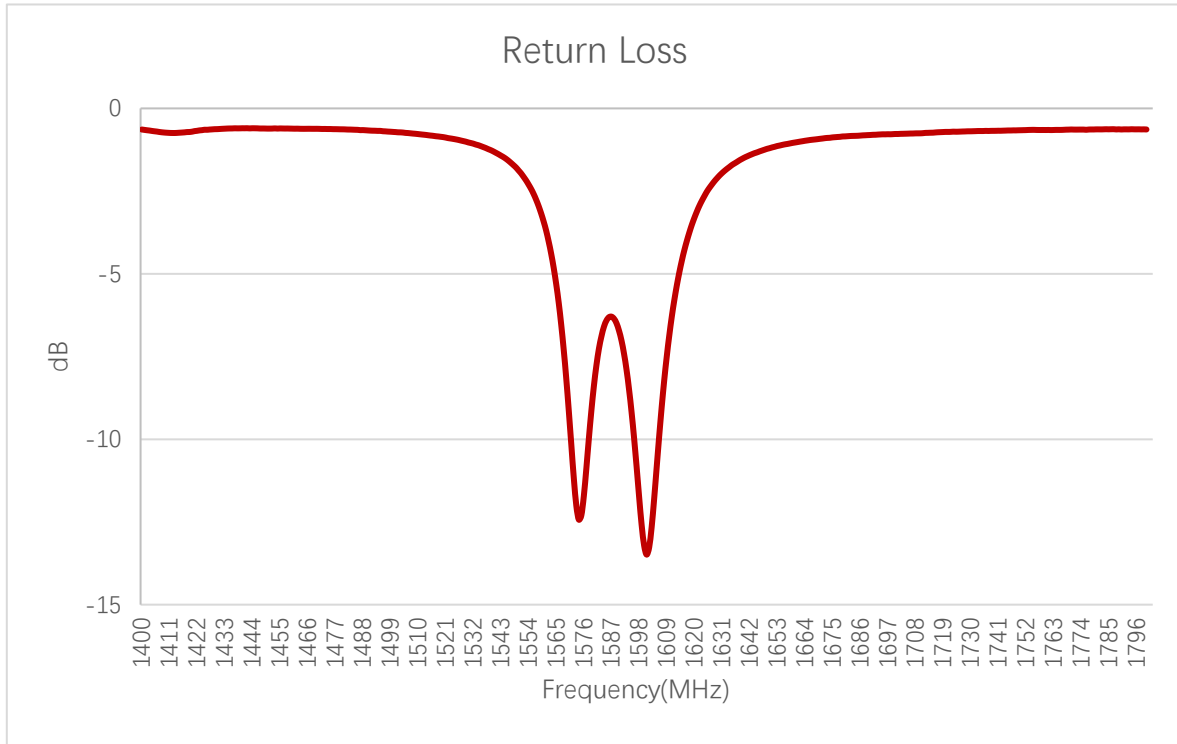

**Return Loss(dB) – GNSS**

Frequency (MHz)	1176	1207	1227	1248	1268	1561	1575	1602
Return Loss (dB)	-	-	-	-	-	-3.7	-12.3	-13.2

**3.1.3. Isolation**

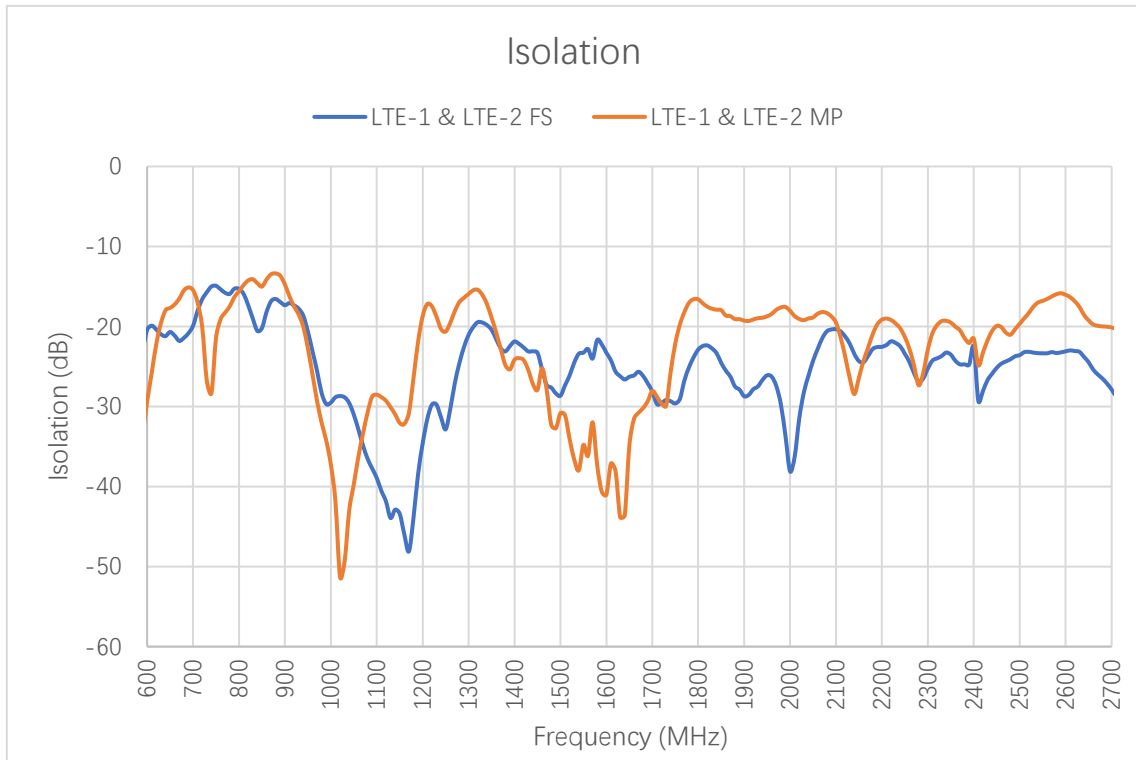

**Max Isolation (dB)**

Band	B71	B12/ B13/ B28	B5/ B8/ B26	n74/ n75/ n76	B1/ B2/ B3	B40	Wi-Fi 2G	B38/ B41	B42/ B48/ n77	BDS B1I	GPS L1	
Freq. (MHz)	600– 700	700– 810	820– 960	1420– 1520	1700– 2170	2300– 2400	2400– 2500	2500– 2690	3300– 4200	1559– 1564	1565– 1586	
LTE-1 & LTE-2	FS	-19.9	-14.9	-16.6	-22.6	-20.3	-22.5	-22.5	-23.0	-	-	-
	MP	-15.1	-14.8	-13.4	-24.2	-16.6	-19.3	-19.6	-15.8	-	-	-

**3.1.4. GNSS LNA Gain**

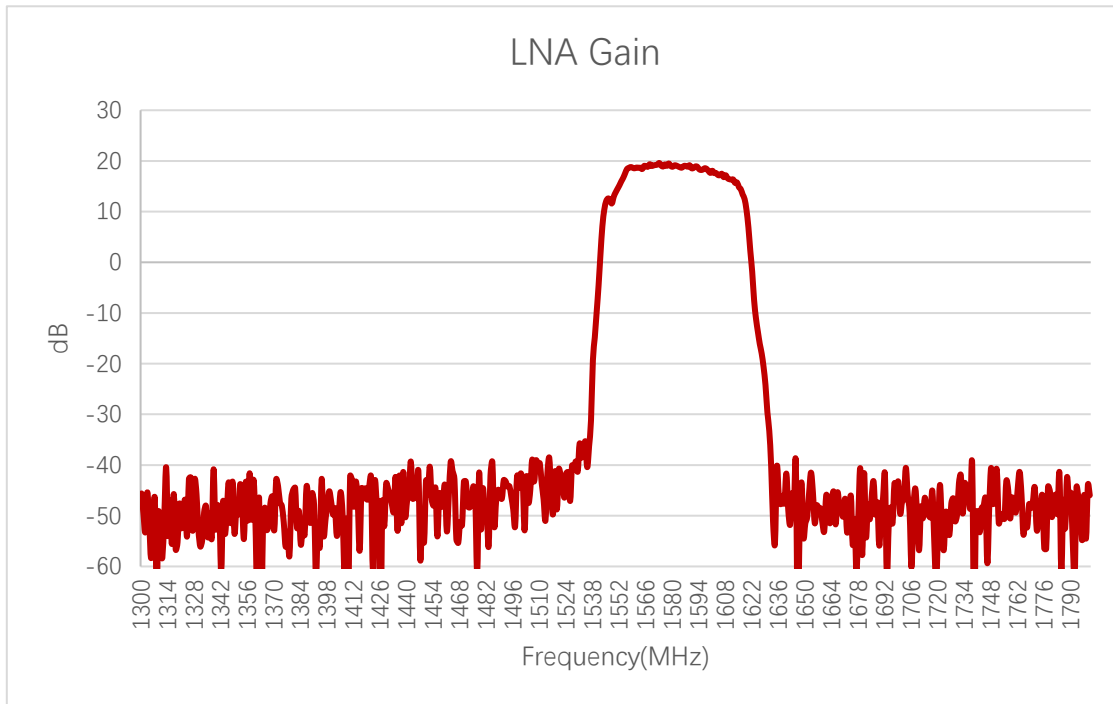

**LNA Gain (dB)**

Frequency (MHz)	1176	1207	1227	1248	1268	1561	1575	1602
LNA Gain (dB)	-	-	-	-	-	18.7	18.8	17.5

**3.1.5. GNSS Noise Figure**

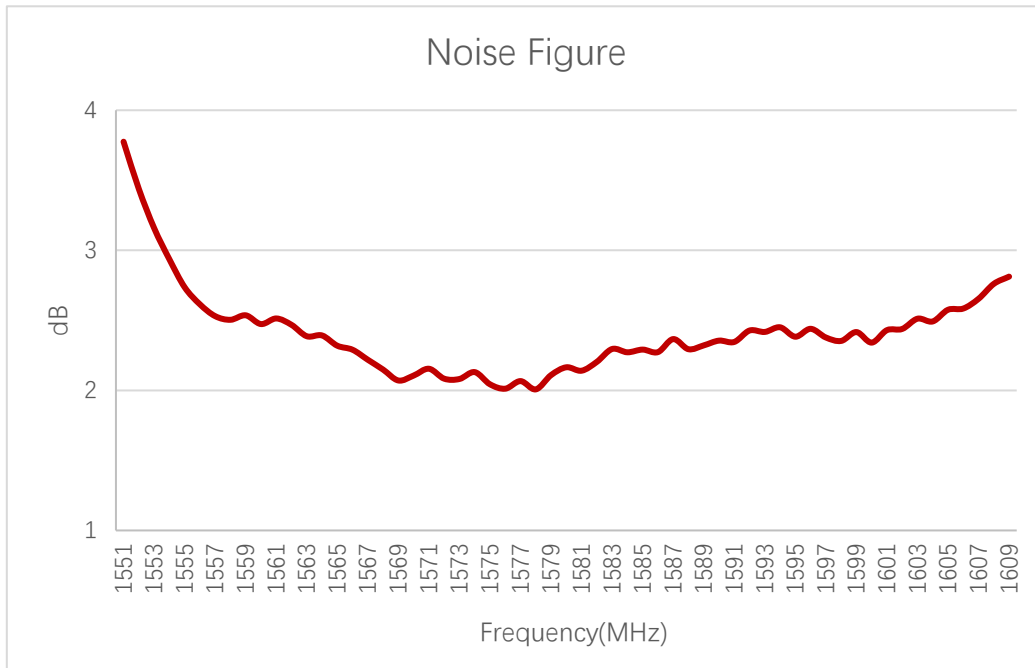

**Noise Figure (dB)**

Frequency (MHz)	1176	1207	1227	1248	1268	1561	1575	1602
Noise Figure (dB)	-	-	-	-	-	2.5	2.04	2.43

### 3.2. Radiation Performance Test

#### 3.2.1. Efficiency

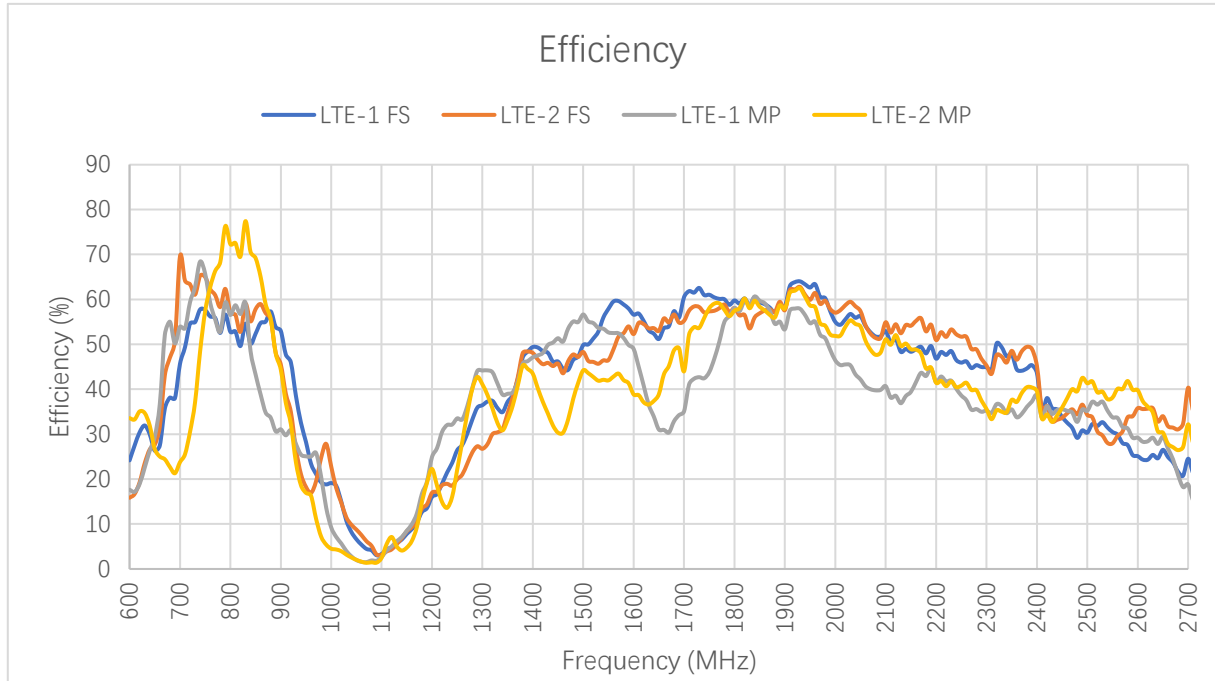

**Efficiency (%) – LTE**

Frequency (MHz)		600	630	710	830	900	960	1440	1710	1740	1880
LTE-1	FS	24.2	31.9	49.3	54.6	53.0	23.4	-	61.8	61.0	57.1
	MP	17.6	22.5	53.6	59.3	31.1	25.0	-	41.1	42.4	54.6
LTE-2	FS	15.8	23.5	64.2	59.0	45.6	16.9	-	57.5	57.1	57.2
	MP	33.6	34.7	25.5	77.4	44.4	16.3	-	52.2	55.9	56.0
Frequency (MHz)		1950	2140	2350	2450	2600	2690	4700	5000	5500	6000
LTE-1	FS	62.6	49.0	47.8	33.8	25.1	20.8	-	-	-	-
	MP	54.7	38.5	35.5	35.5	29.2	18.2	-	-	-	-
LTE-2	FS	59.9	54.3	48.6	33.6	35.8	32.3	-	-	-	-
	MP	58.6	50.2	37.6	35.9	39.8	27.2	-	-	-	-

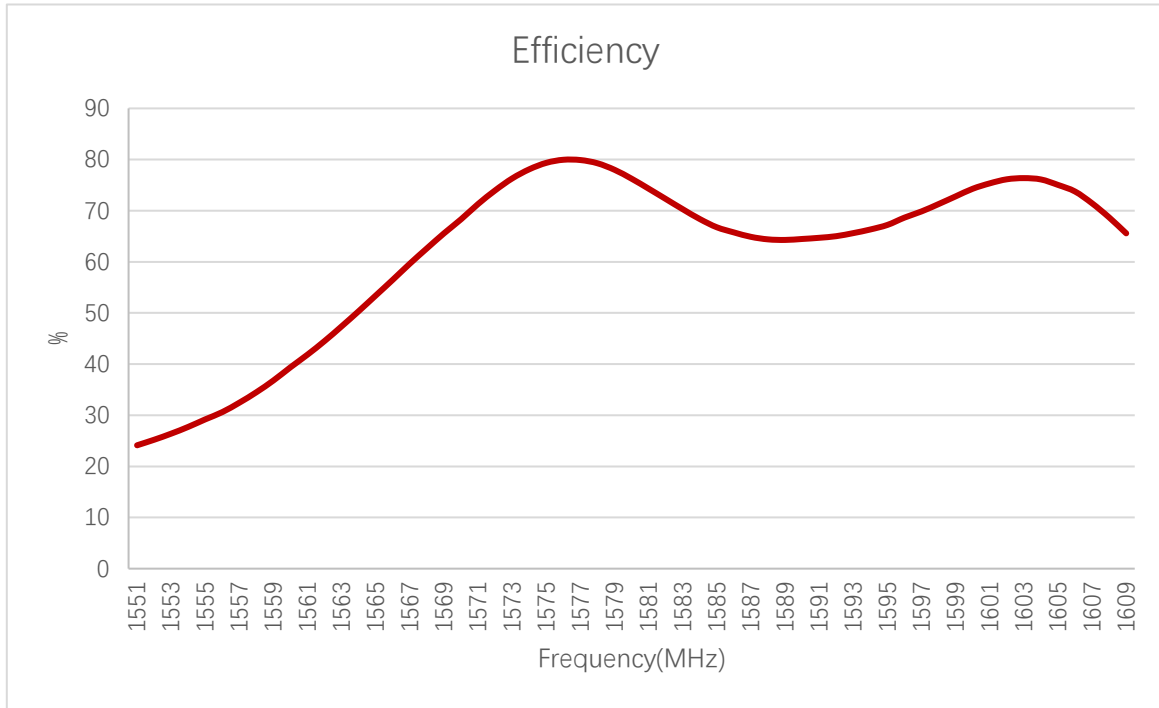

**Efficiency (%) – GNSS**

Frequency (MHz)	1176	1207	1227	1248	1268	1561	1575	1602
Efficiency (%)	-	-	-	-	-	42	79	76

**3.2.2. Average Gain**

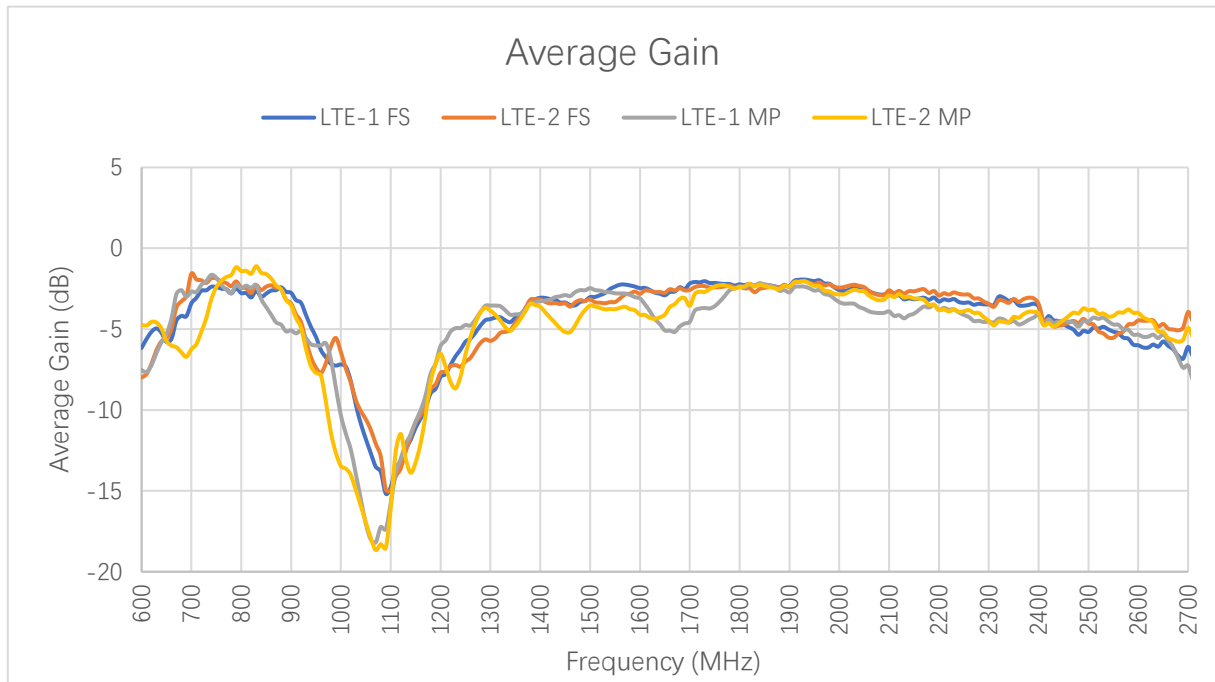

**Average Gain (dB) – LTE**

Frequency (MHz)		600	630	710	830	900	960	1440	1710	1740	1880
LTE-1	FS	-6.2	-5.0	-3.1	-2.6	-2.8	-6.3	-	-2.1	-2.1	-2.4
	MP	-7.5	-6.5	-2.7	-2.3	-5.1	-6.0	-	-3.9	-3.7	-2.6
LTE-2	FS	-8.0	-6.3	-1.9	-2.3	-3.4	-7.7	-	-2.4	-2.4	-2.4
	MP	-4.7	-4.6	-5.9	-1.1	-3.5	-7.9	-	-2.8	-2.5	-2.5
Frequency (MHz)		1950	2140	2350	2450	2600	2690	4700	5000	5500	6000
LTE-1	FS	-2.0	-3.1	-3.2	-4.7	-6.0	-6.8	-	-	-	-
	MP	-2.6	-4.1	-4.5	-4.5	-5.3	-7.4	-	-	-	-
LTE-2	FS	-2.2	-2.7	-3.1	-4.7	-4.5	-4.9	-	-	-	-
	MP	-2.3	-3.0	-4.2	-4.4	-4.0	-5.7	-	-	-	-

**3.2.3. Peak Gain**

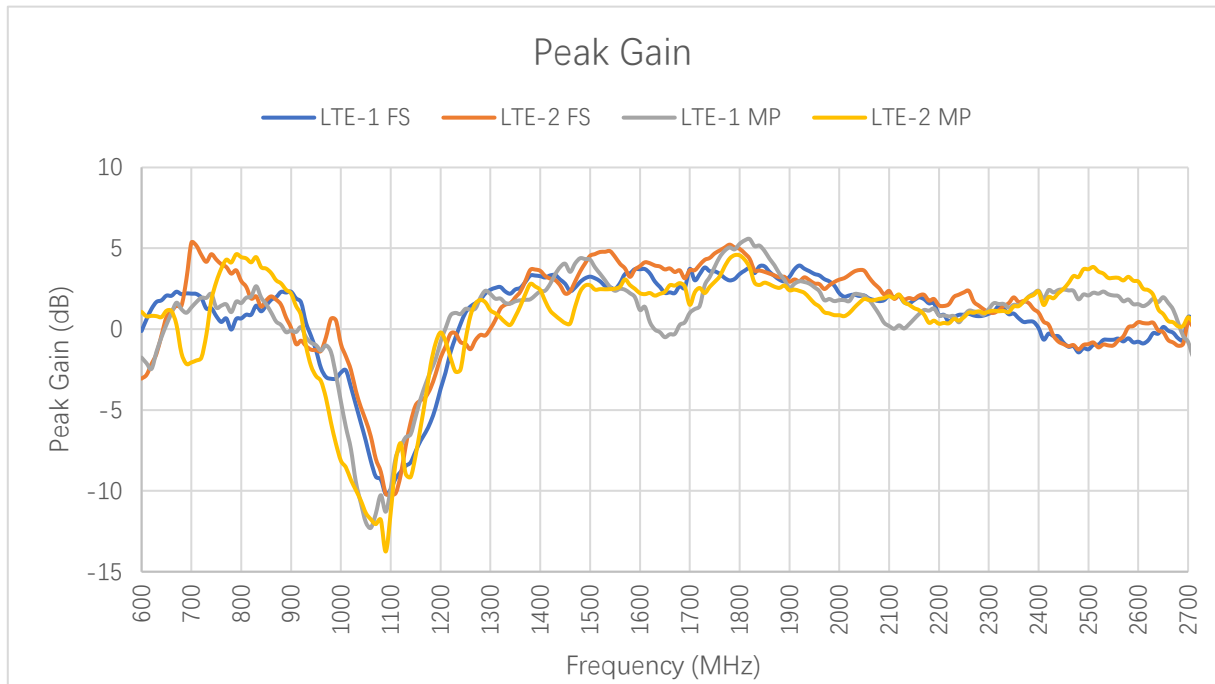

**Peak Gain (dBi) – LTE**

Frequency (MHz)		600	630	710	830	900	960	1440	1710	1740	1880
LTE-1	FS	-0.1	1.7	2.2	1.5	2.3	-2.4	3.1	3.0	3.6	3.1
	MP	-1.8	-1.4	1.7	2.7	-0.1	-1.3	3.8	1.2	3.2	3.4
LTE-2	FS	-3.1	-1.5	5.2	2.0	0.1	-1.4	2.7	3.6	4.4	3.2
	MP	1.1	0.8	-1.9	4.5	2.2	-3.2	0.6	2.3	2.6	2.6
Frequency (MHz)		1950	2140	2350	2450	2600	2690	4700	5000	5500	6000
LTE-1	FS	3.4	1.6	1.0	-0.8	-0.8	-0.7	-	-	-	-
	MP	2.6	0.3	1.5	2.5	1.5	-0.4	-	-	-	-
LTE-2	FS	2.8	1.9	2.0	-0.9	0.4	-0.9	-	-	-	-
	MP	1.6	1.5	1.4	2.5	2.9	0.2	-	-	-	-

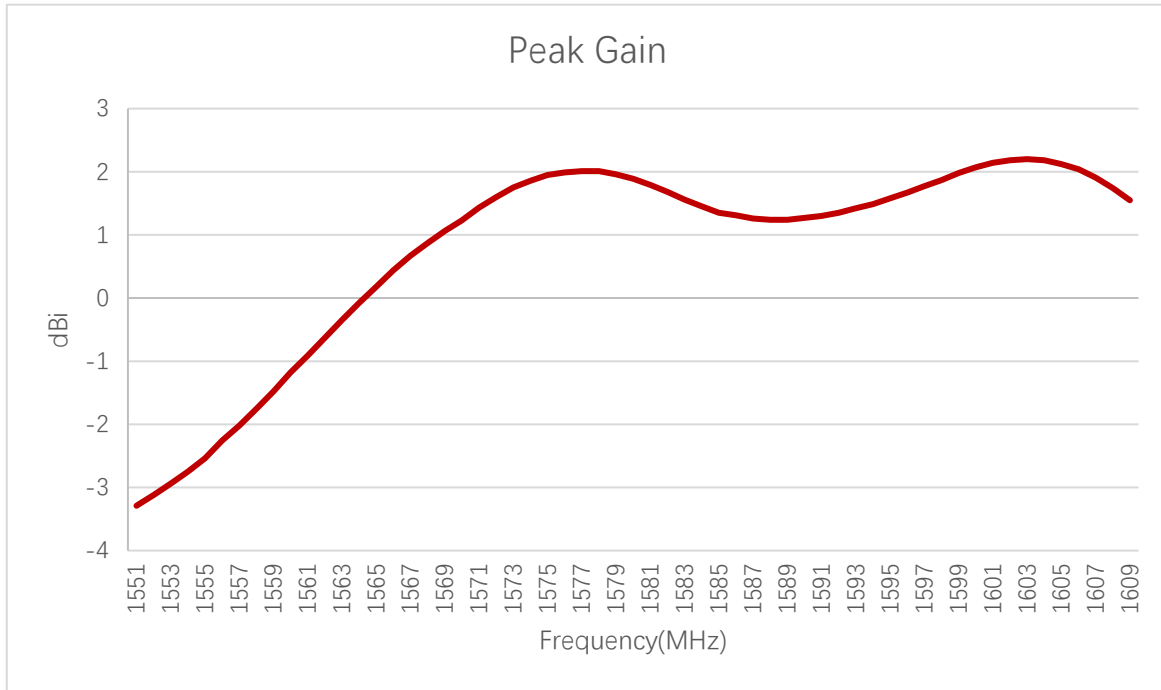

**Peak Gain (dBi) – GNSS**

Frequency (MHz)	1176	1207	1227	1248	1268	1561	1575	1602
Peak Gain (dBi)	-	-	-	-	-	-0.91	1.95	2.18

### 3.2.4. 3D & 2D Radiation Pattern

- Test Condition: Free space
- Test Chamber: FS-S-1 (LTE); SH-SY-16 (GNSS)

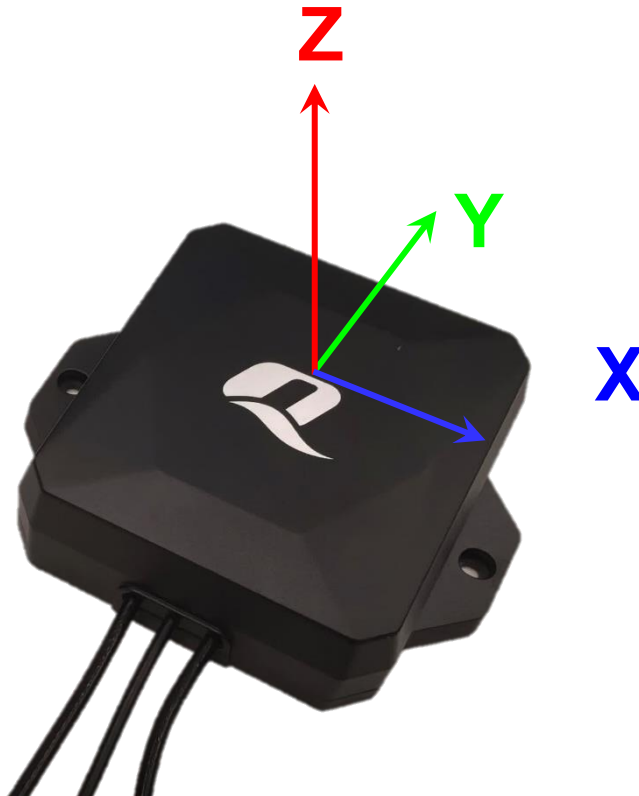

● **LTE-1**

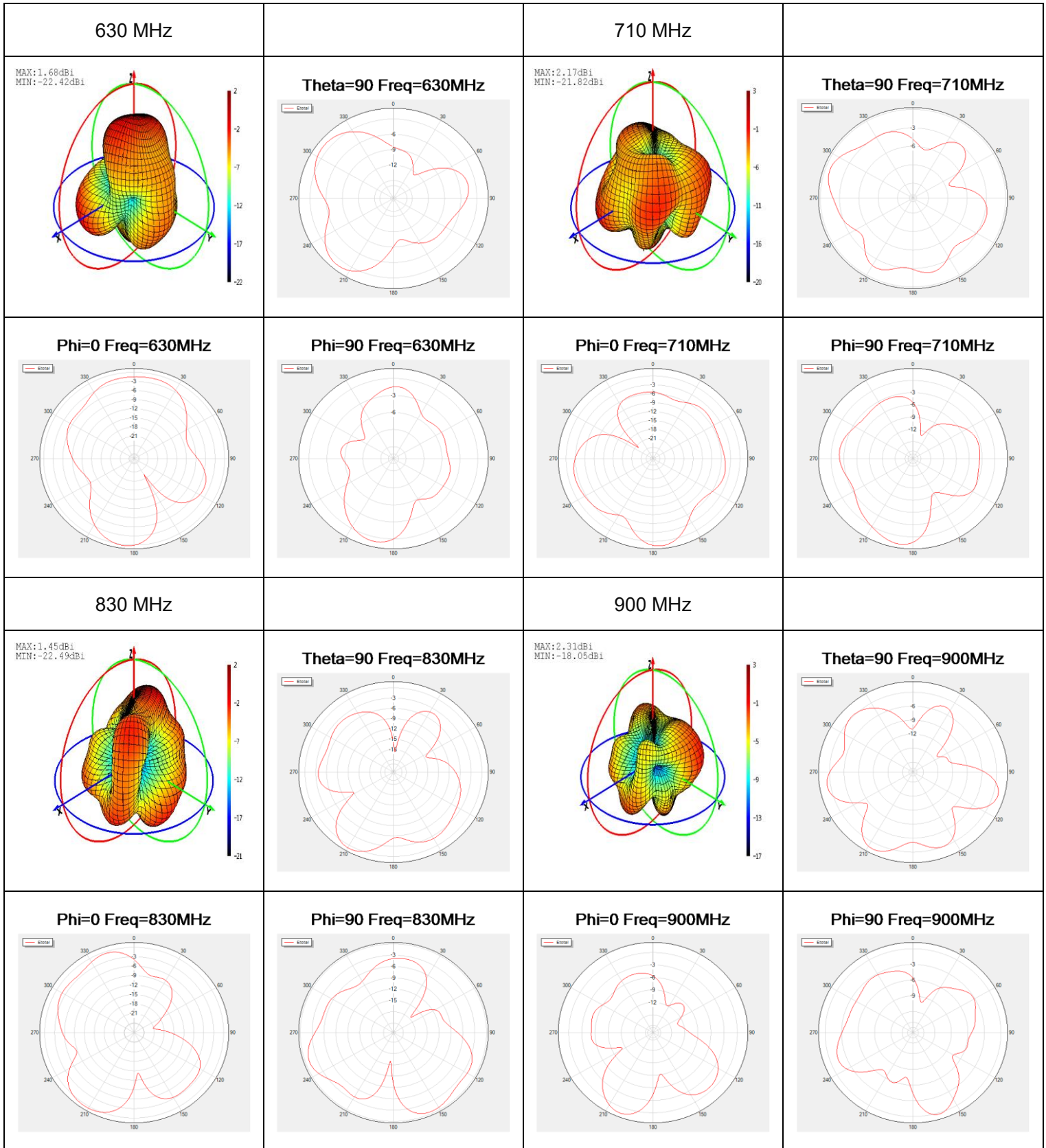

**1740 MHz**

MAX: 3.58dBi  
MIN: -23.16dBi

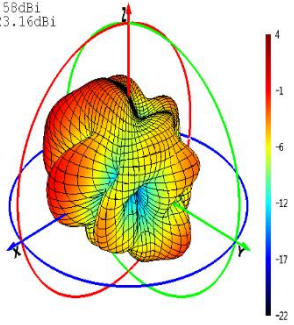

**Theta=90 Freq=1740MHz**

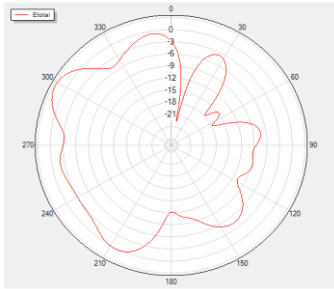

**1880 MHz**

MAX: 3.05dBi  
MIN: -32.12dBi

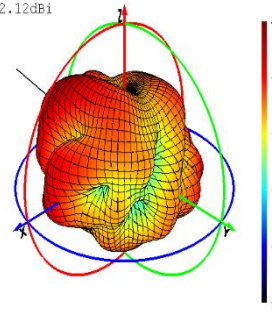

**Theta=90 Freq=1880MHz**

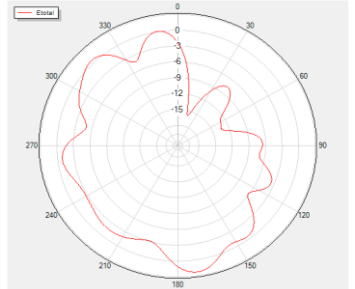

**Phi=0 Freq=1740MHz**

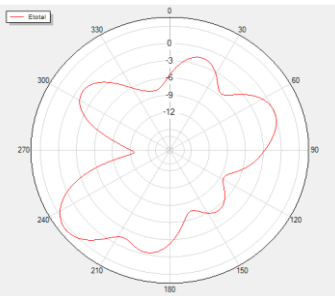

**Phi=90 Freq=1740MHz**

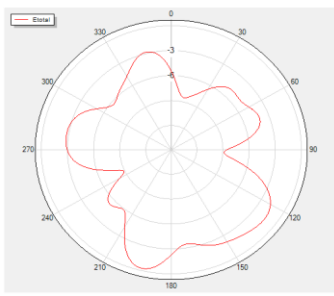

**Phi=0 Freq=1880MHz**

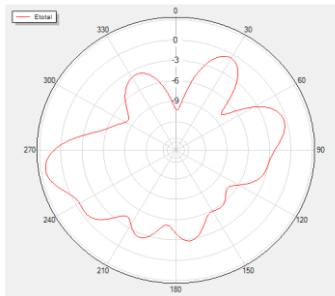

**Phi=90 Freq=1880MHz**

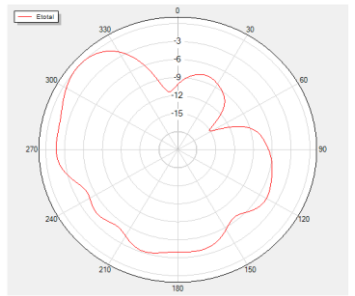

**1950 MHz**

MAX: 3.41dBi  
MIN: -21.75dBi

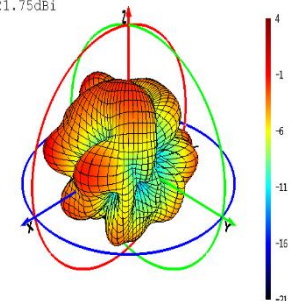

**Theta=90 Freq=1950MHz**

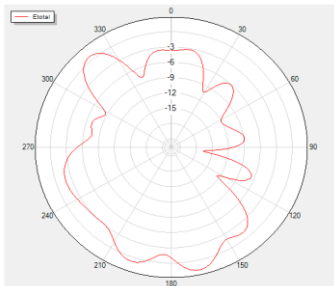

**2140 MHz**

MAX: 1.58dBi  
MIN: -24.04dBi

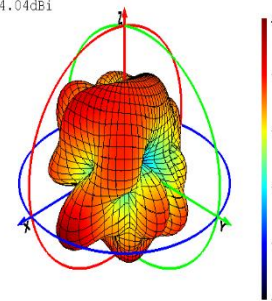

**Theta=90 Freq=2140MHz**

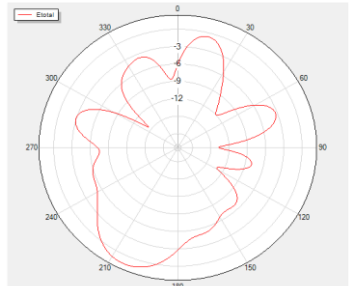

**Phi=0 Freq=1950MHz**

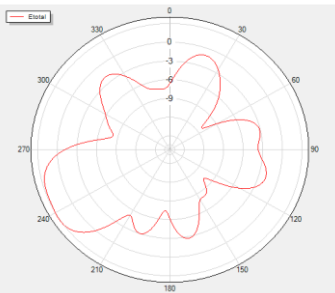

**Phi=90 Freq=1950MHz**

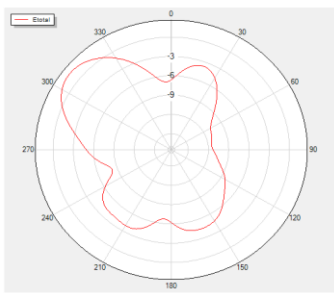

**Phi=0 Freq=2140MHz**

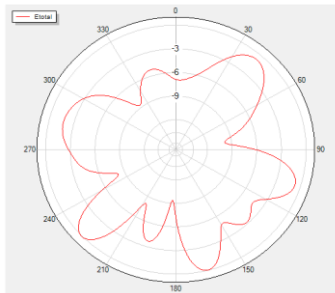

**Phi=90 Freq=2140MHz**

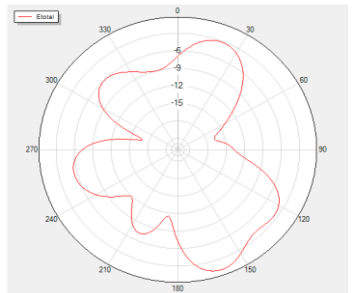

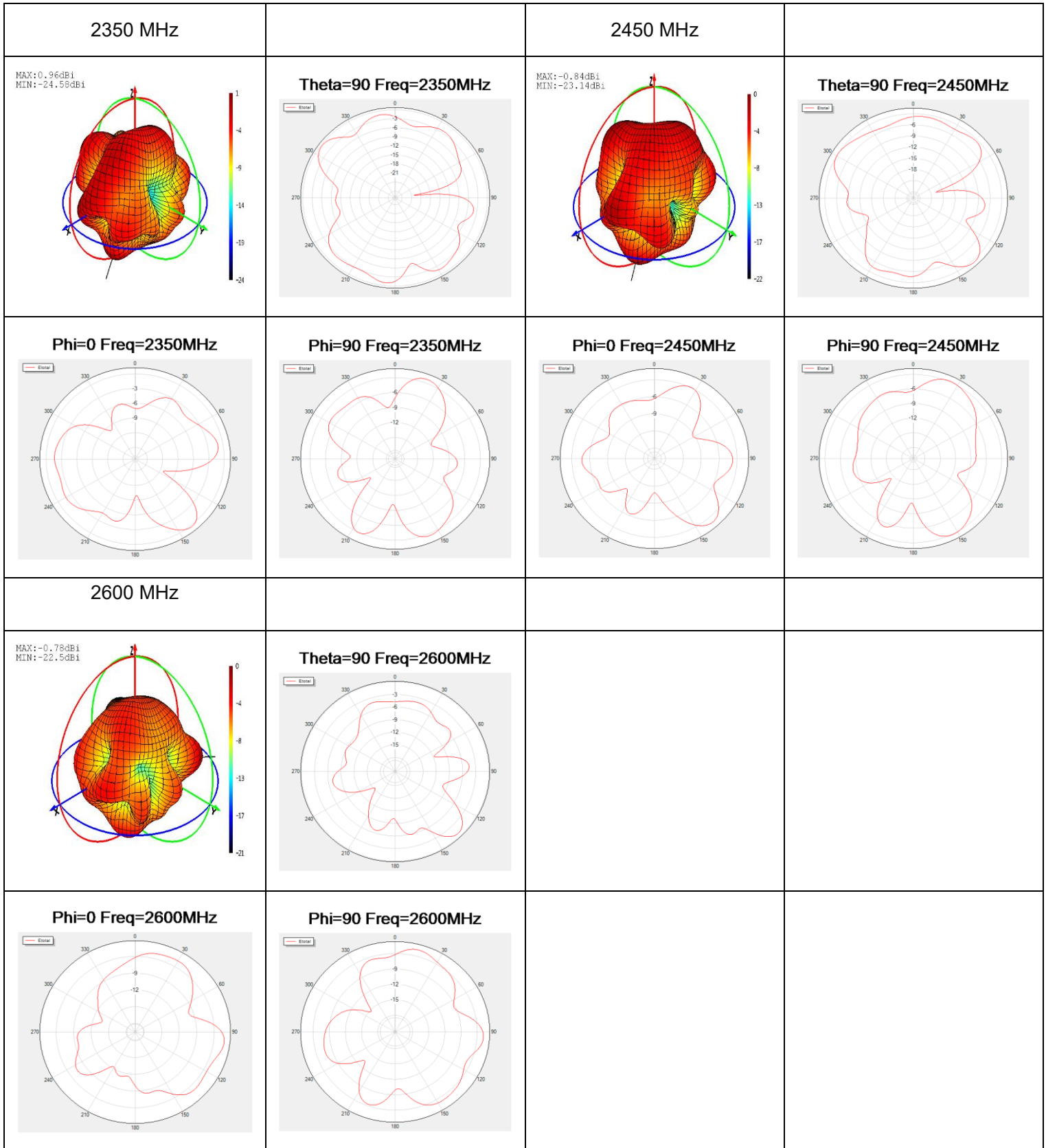

● **LTE-2**

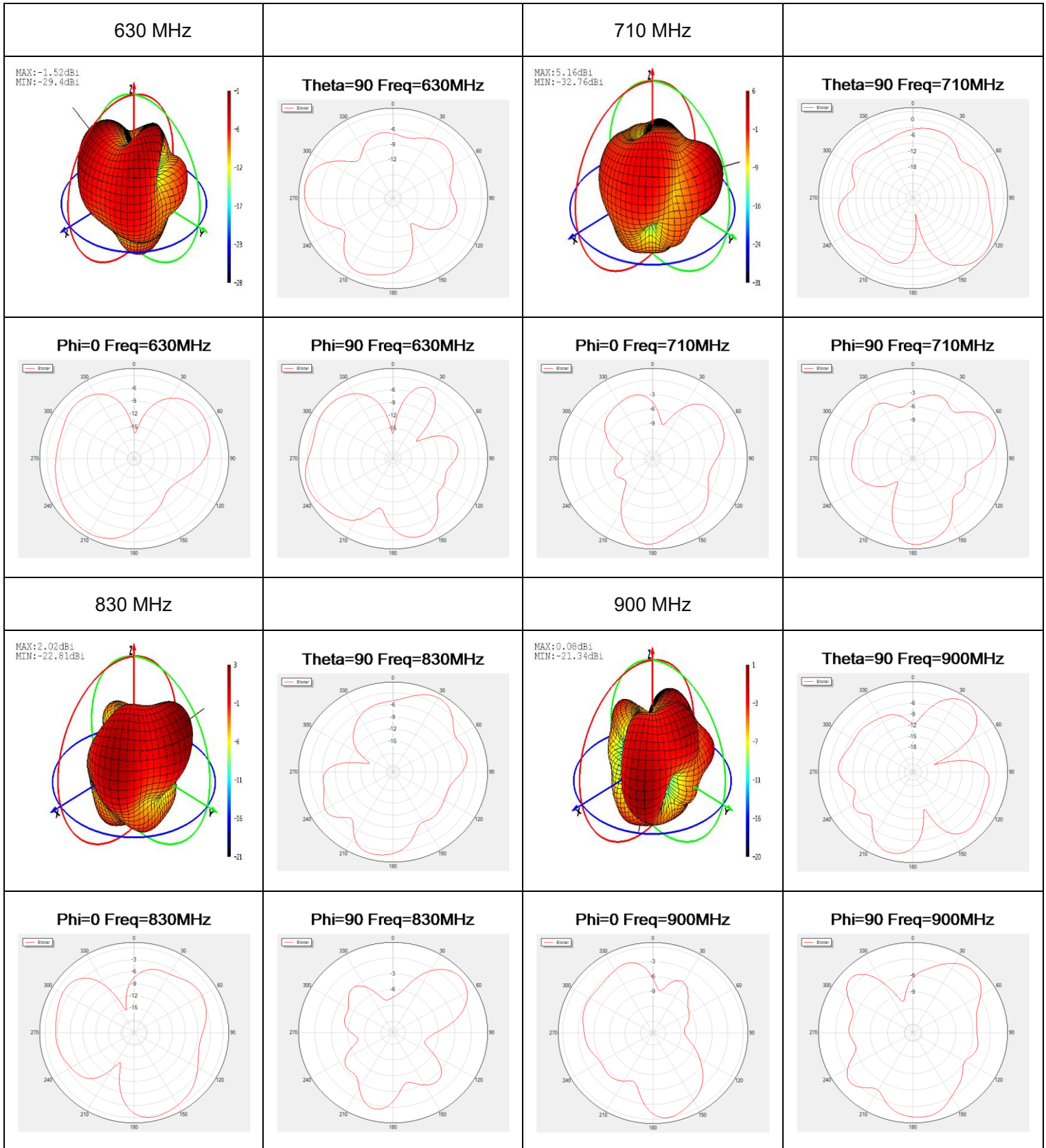

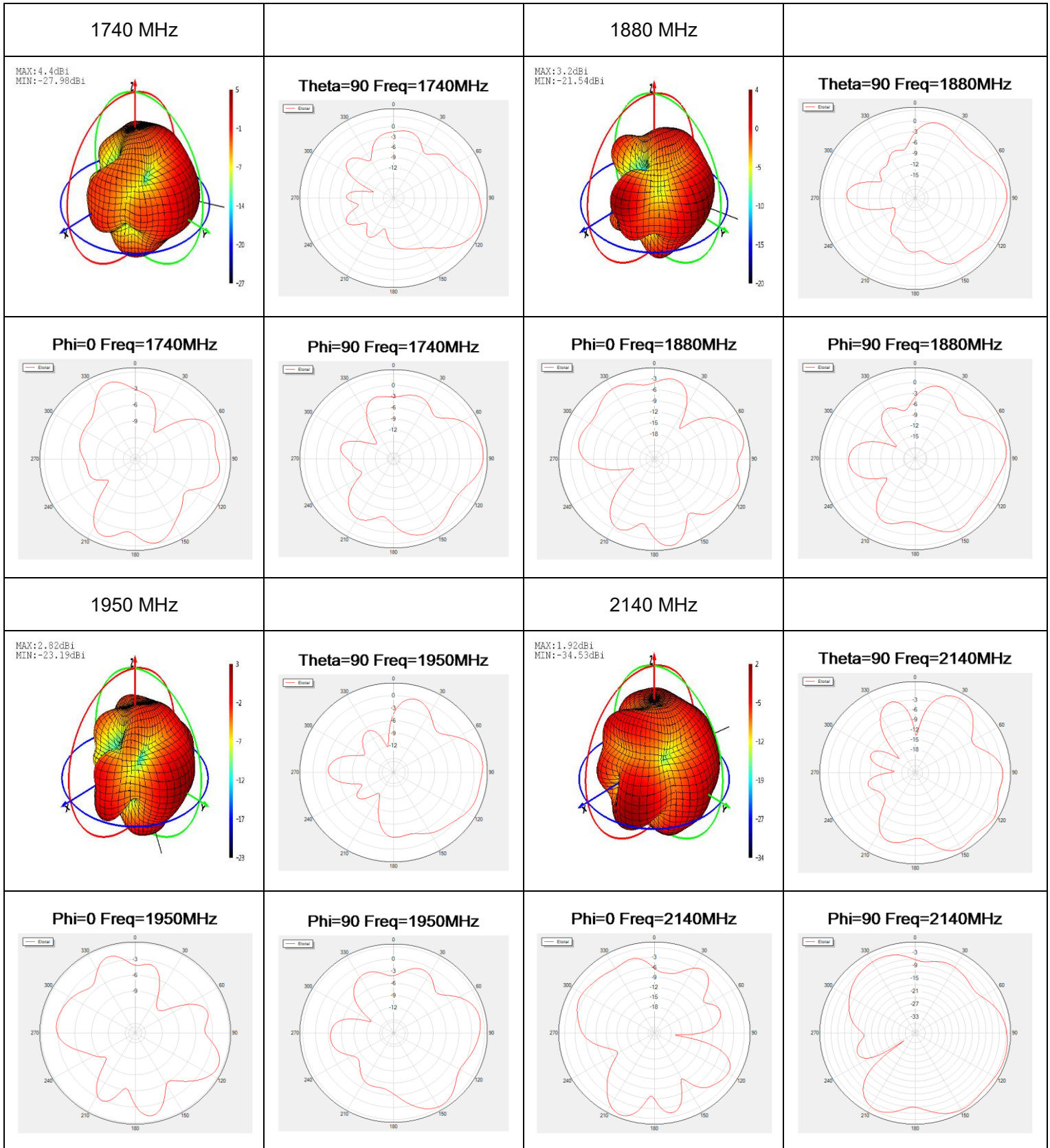

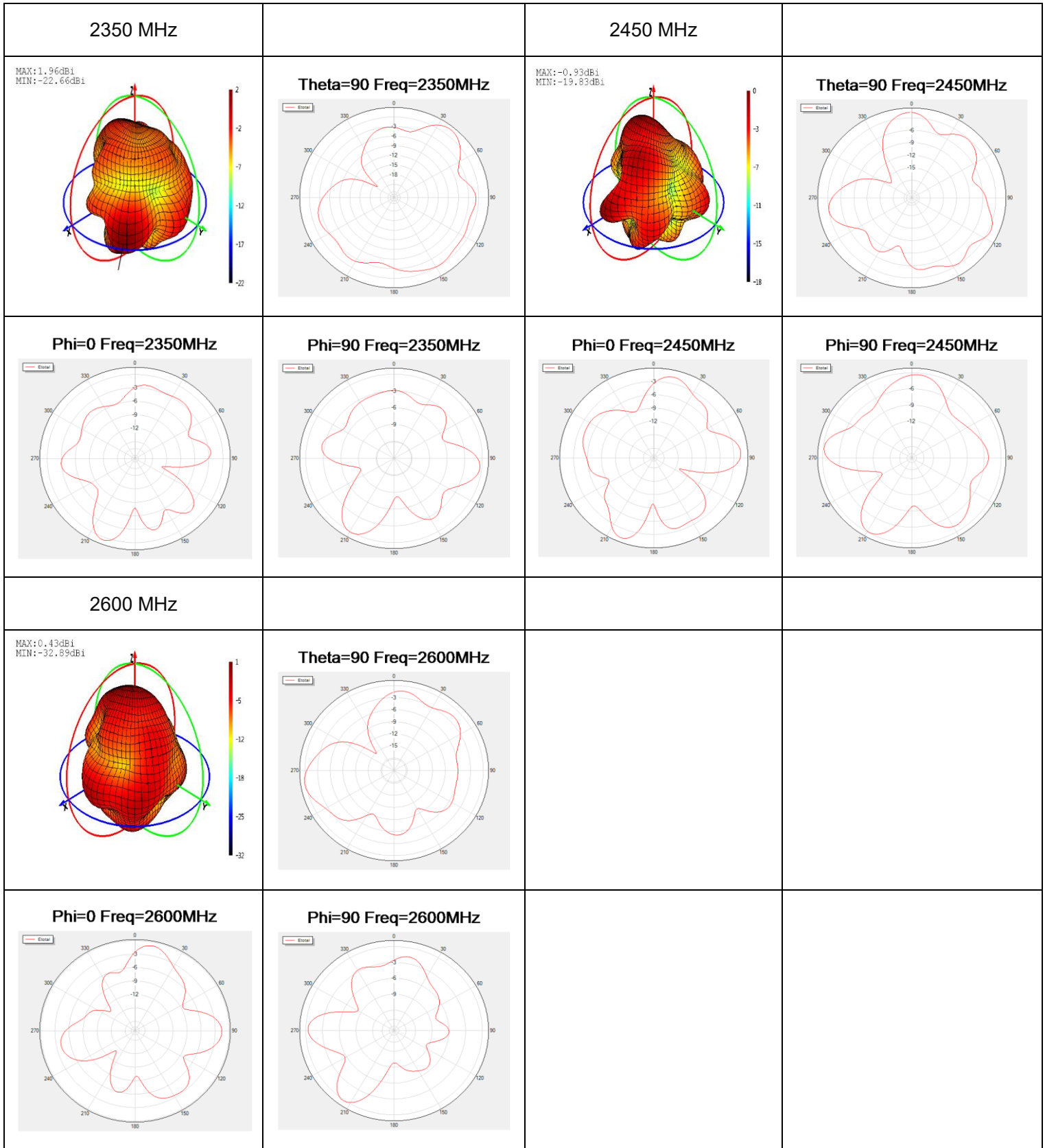

● **GNSS**

1561 MHz

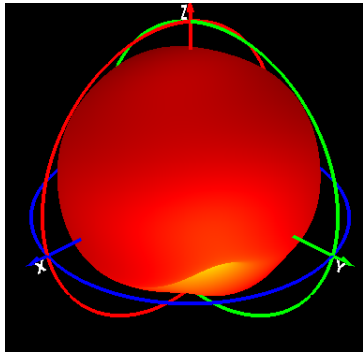

**Phi=0 freq=1561MHz**

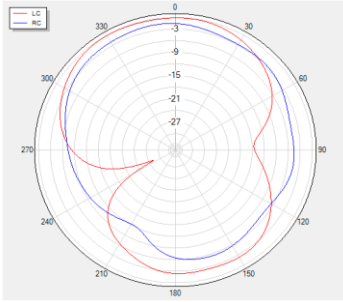

1575 MHz

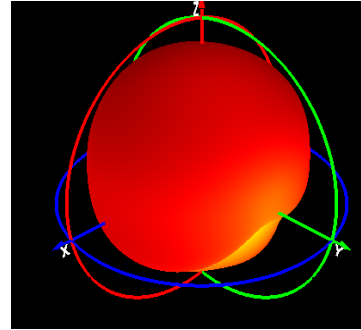

**Phi=0 freq=1575MHz**

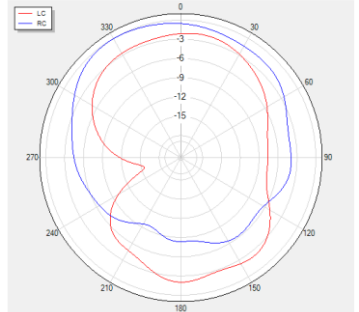

**Phi=90 freq=1561MHz**

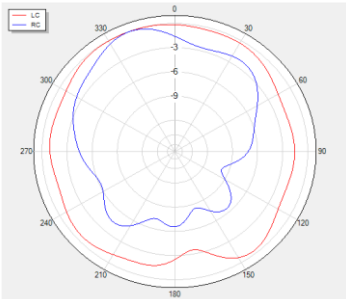

**Theta=90 freq=1561MHz**

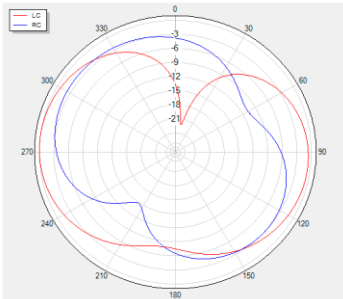

**Phi=90 freq=1575MHz**

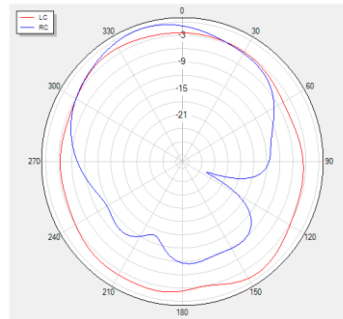

**Theta=90 freq=1575MHz**

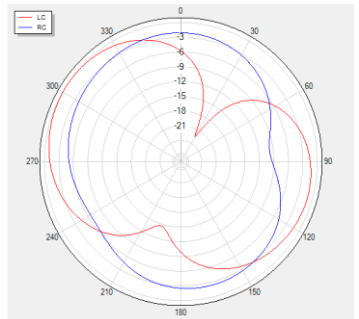

1602 MHz

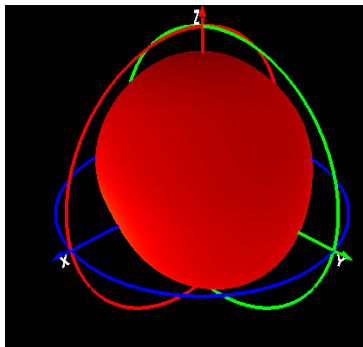

**Phi=0 freq=1602MHz**

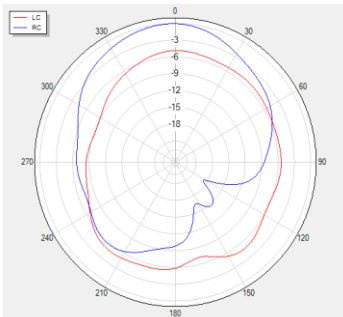

**Phi=90 freq=1602MHz**

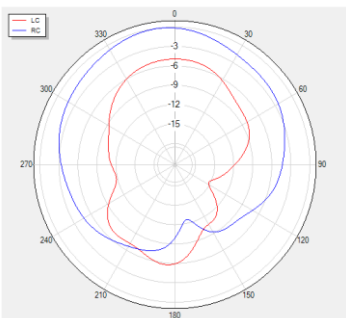

**Theta=90 freq=1602MHz**

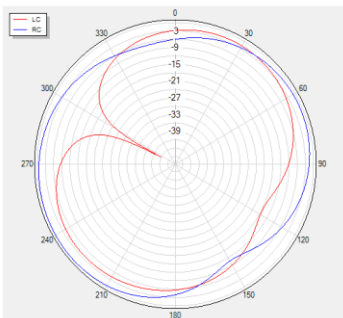

### 3.2.5. 3D & 2D Radiation Pattern

- Test Condition: On 300 mm × 300 mm Metal Plane
- Test Chamber: FS-S-1(LTE)

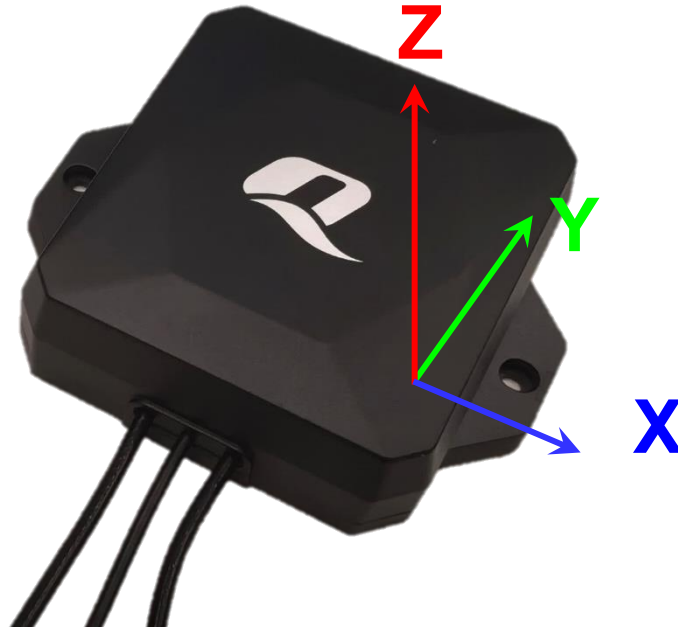

● **LTE-1**

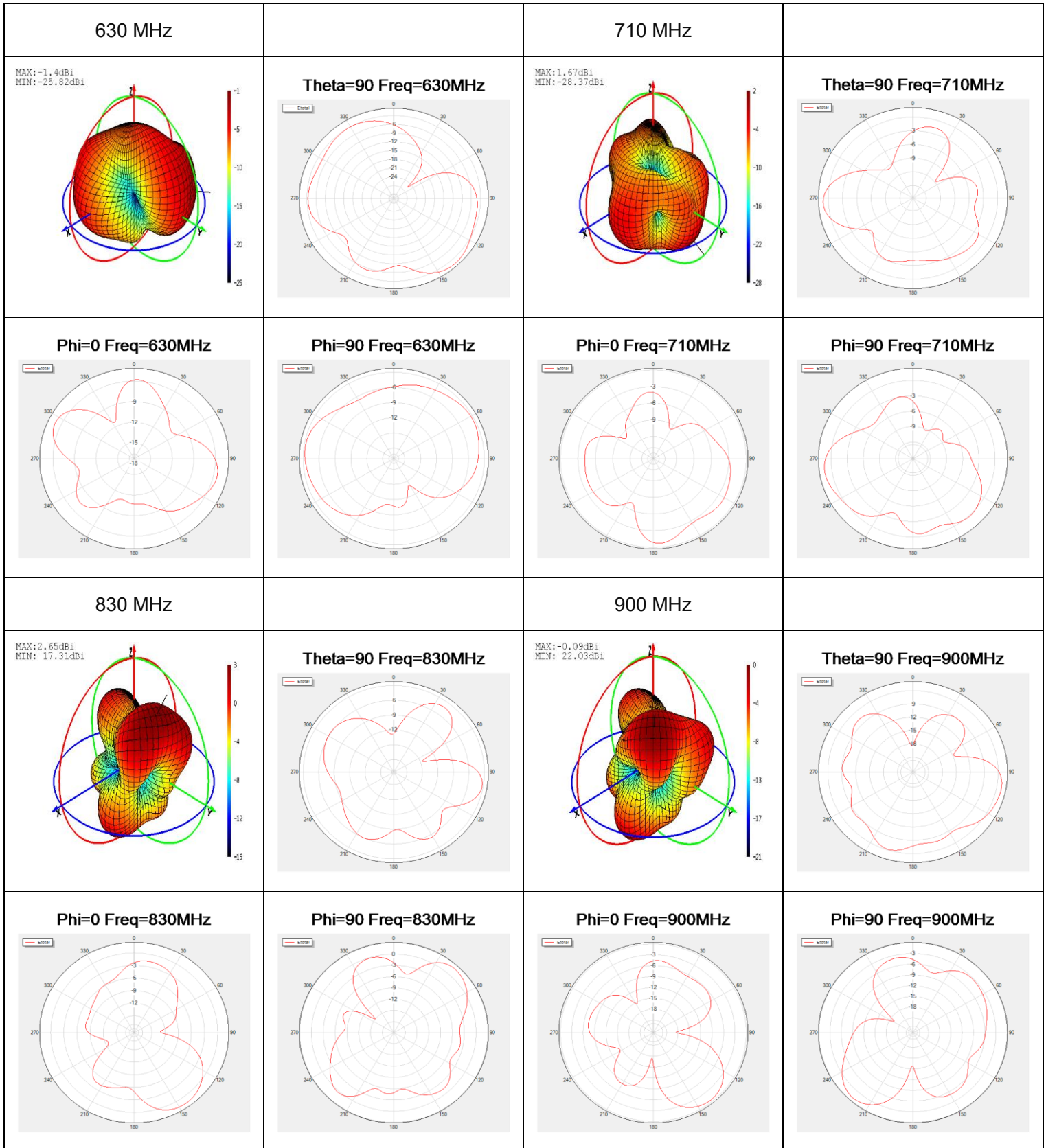

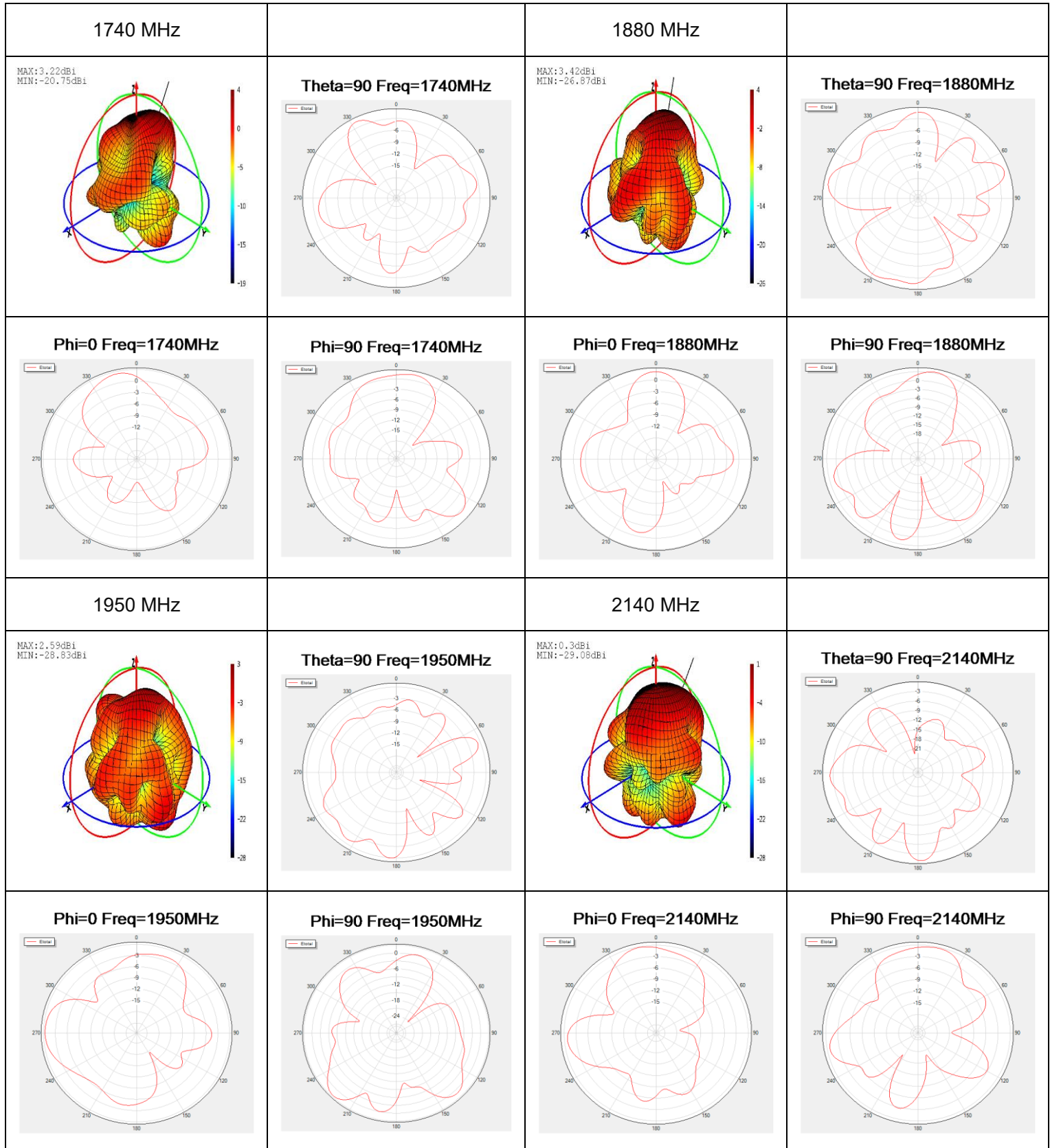

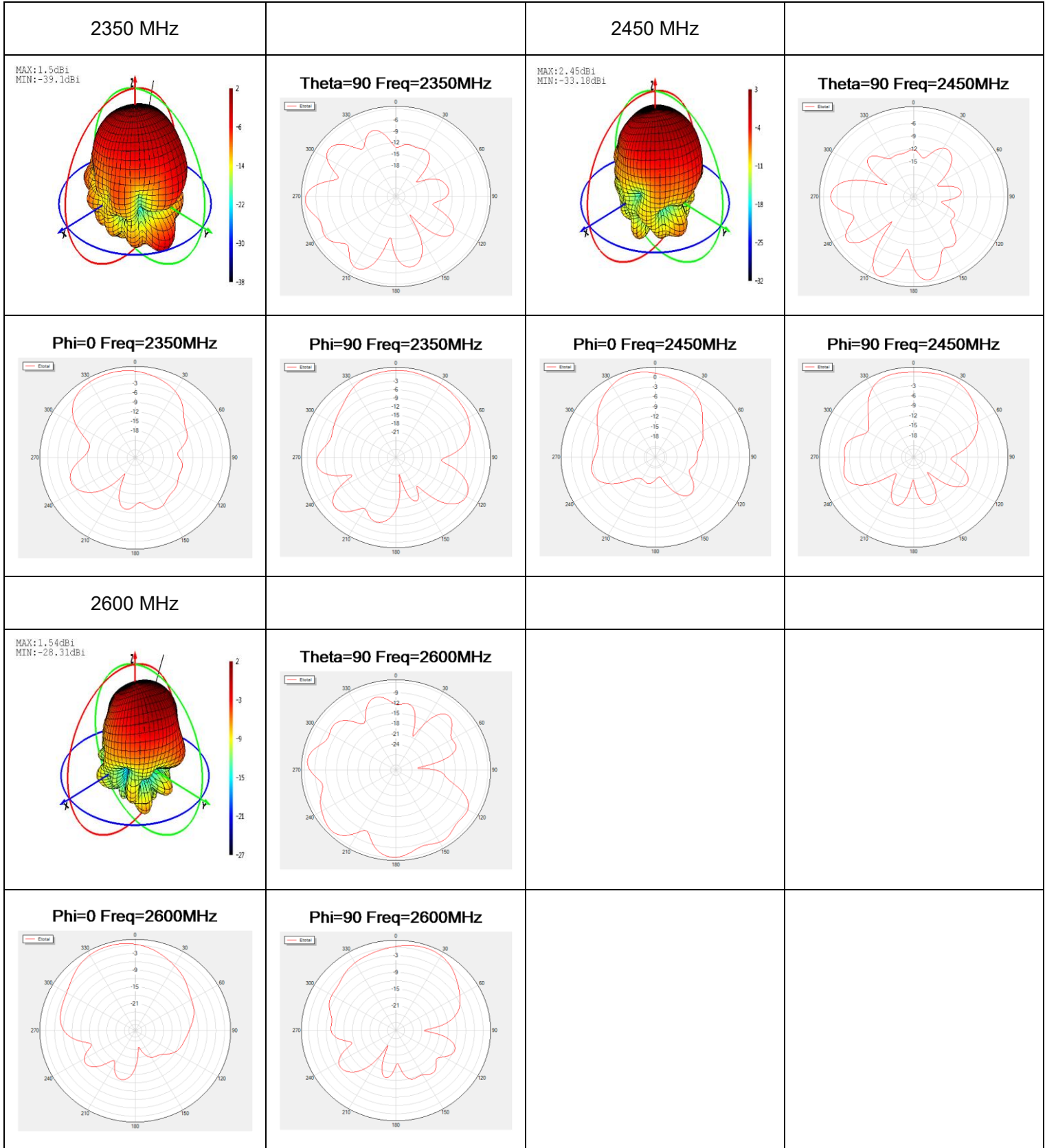

● **LTE-2**

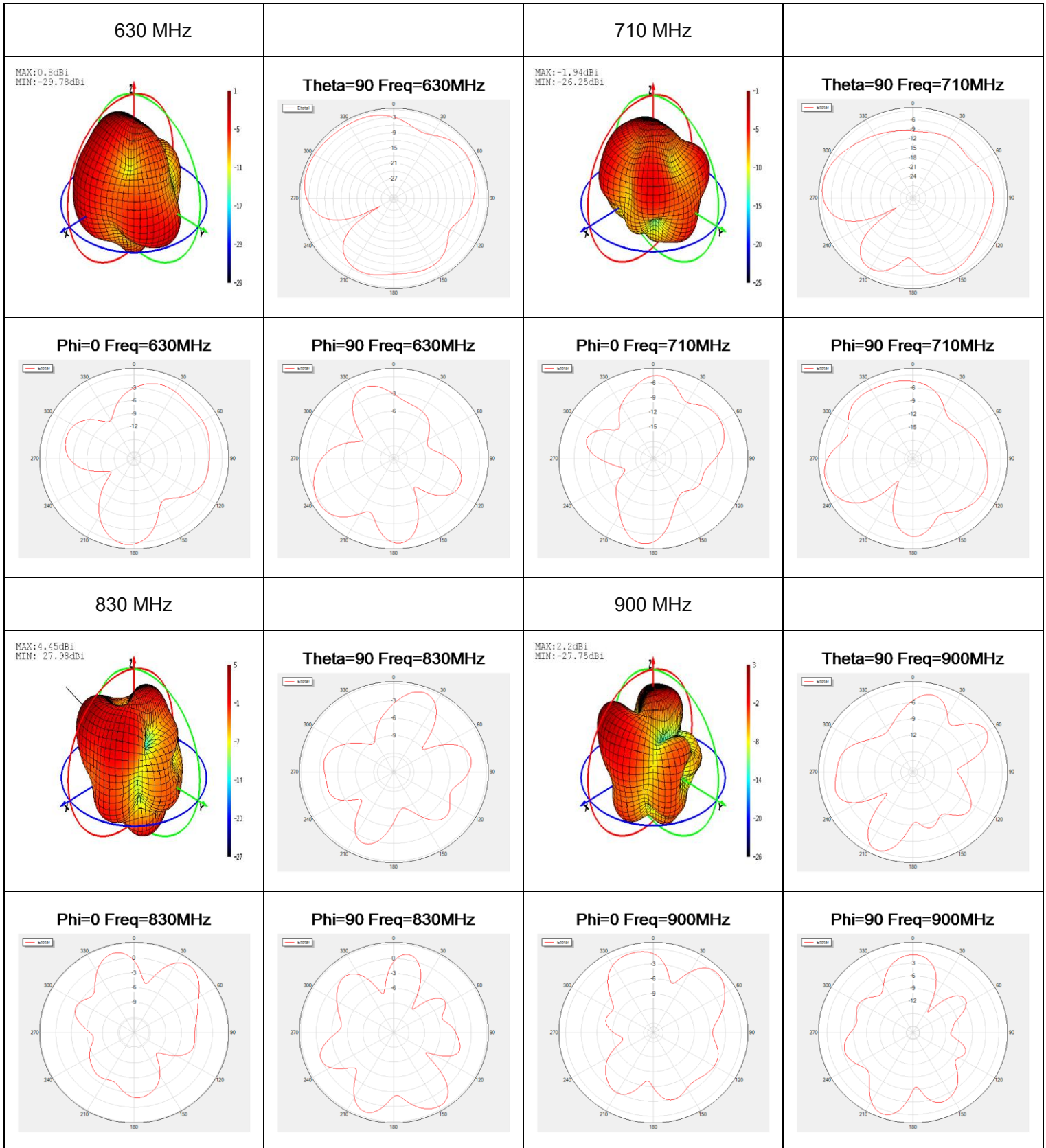

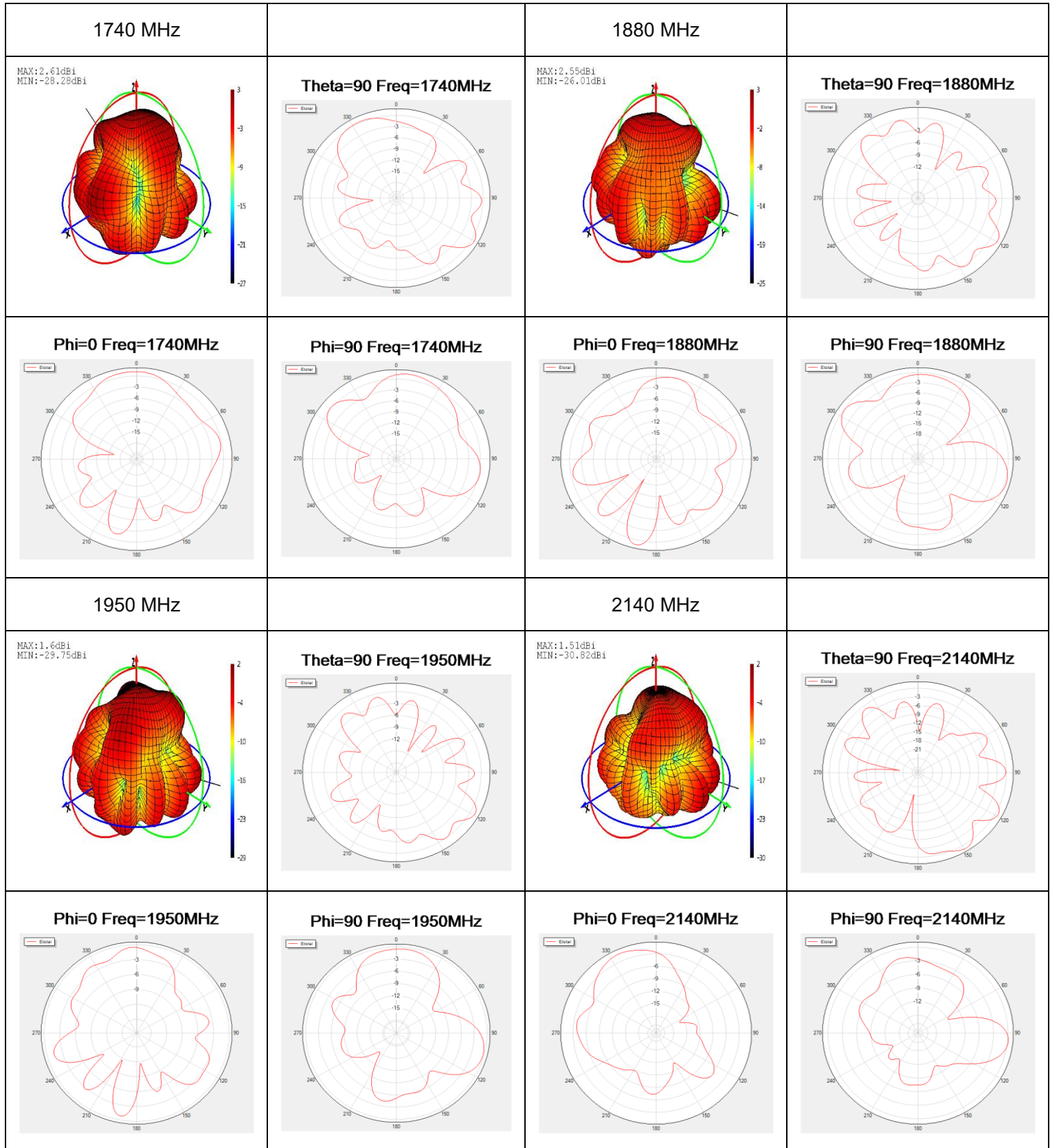

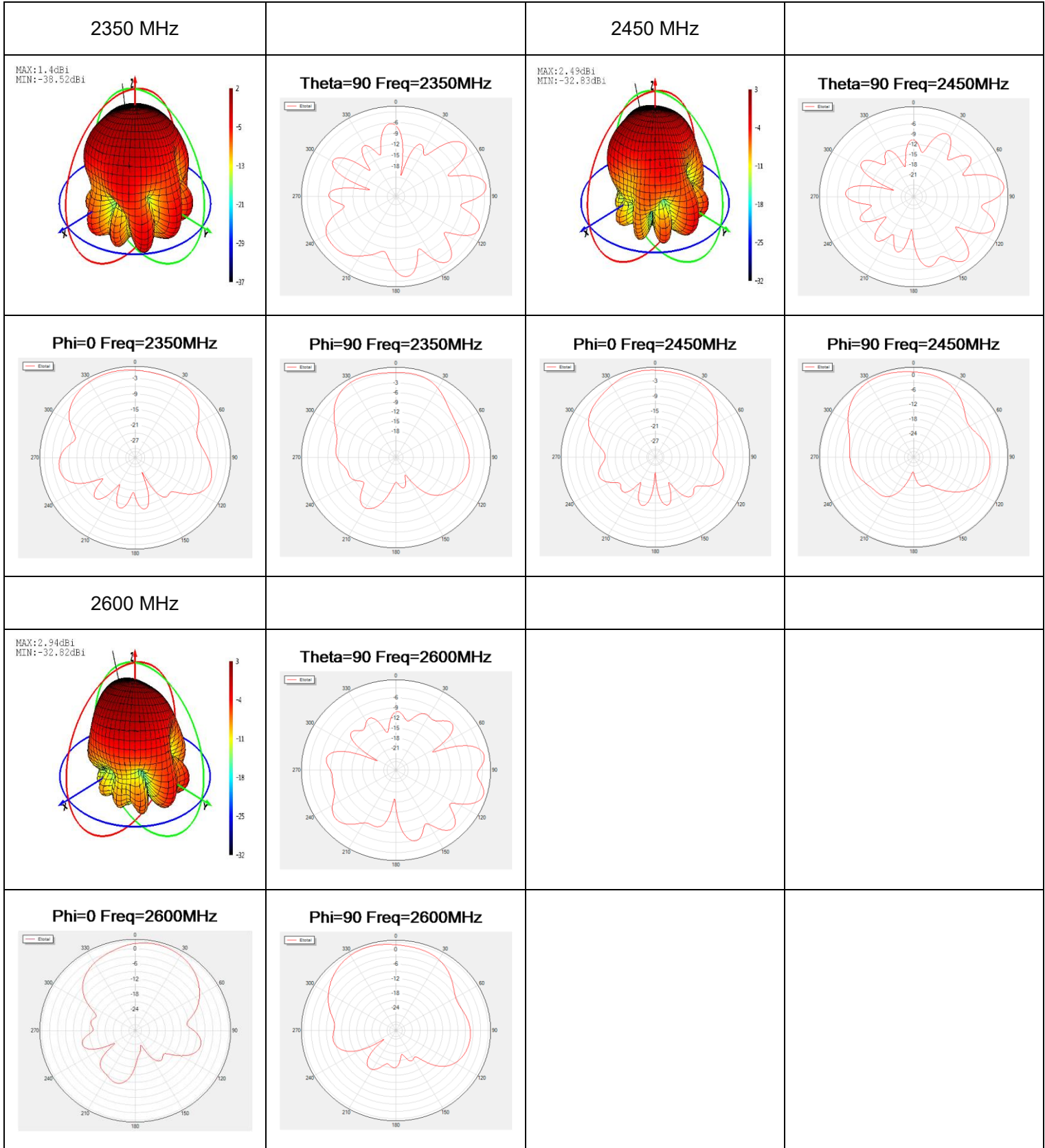

# 4 Installation

Below are three installation methods that can be combined.

- Magnet

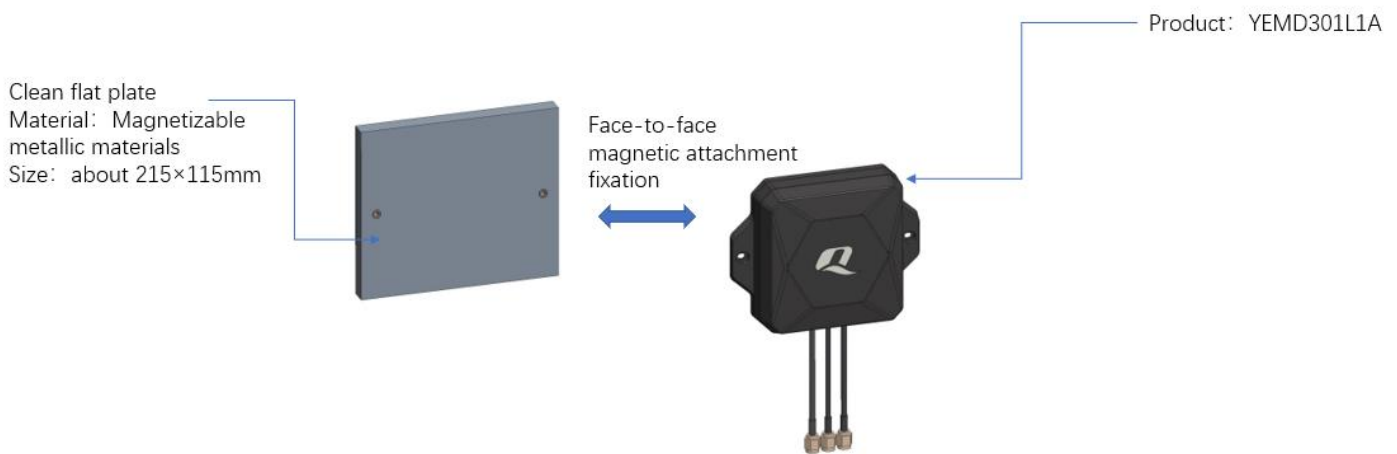

- Adhesive

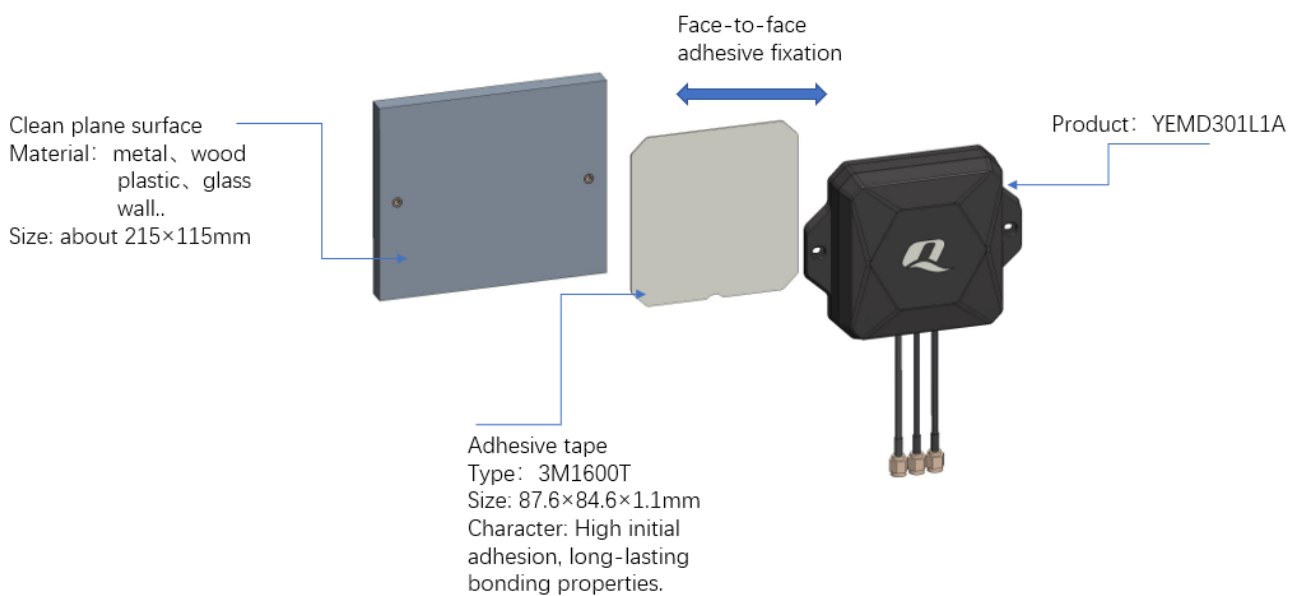

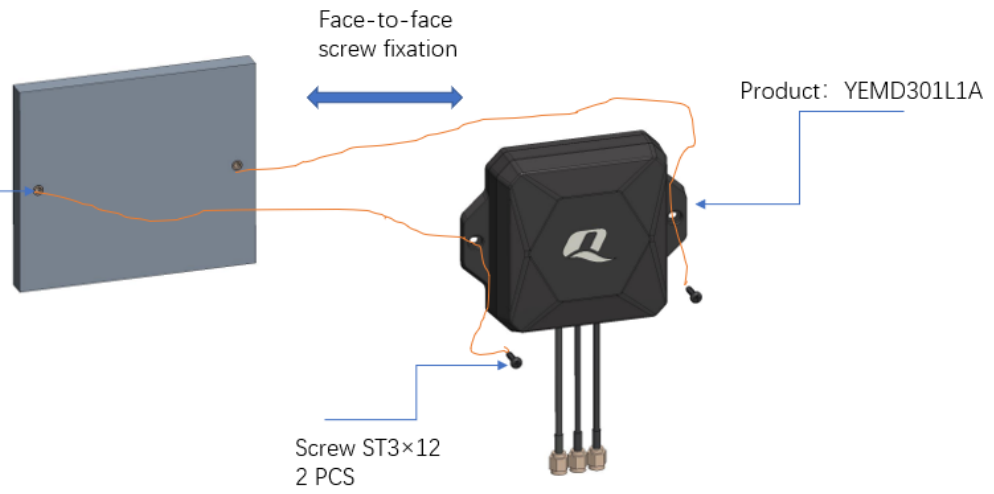

● Screw

Clean flat plate  
Material: metal, wood  
plastic, glass  
wall...  
Size: about 215×115mm  
Plastic stopper  
Quantity: 2  
Suitable for ST3 screw

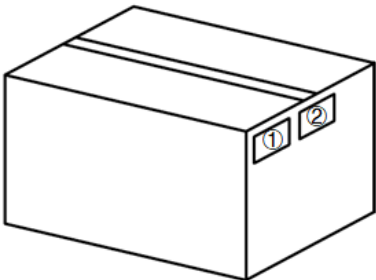

# 5 Packaging

Step	Packaging Picture / 2D Picture	Description
1		<p>1 antenna product in a PE bag. (1 Antenna / PE Bag)</p>
2		<p>5 antenna products in an inner box. (5 Antennas / Inner Box)</p>
3		<p>(6 Inner Boxes / Carton Box) (30 Antennas/ Carton Box)</p> <p><u>Carton Size:</u> <u>L × W × H = 600 × 404 × 164 mm</u></p>
4		<p><b>Position for Attaching Labels</b></p> <ul style="list-style-type: none"> <li>① Carton Label</li> <li>② Quality Label</li> </ul>

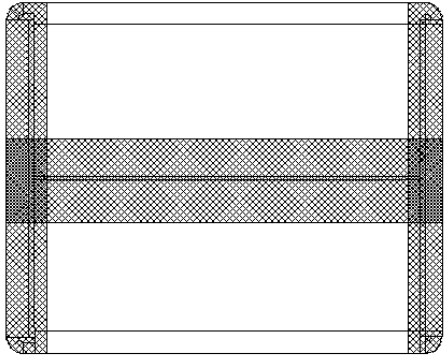
5	 A technical drawing of an H-shaped sealing carton. It consists of two vertical rectangular sections connected by two horizontal rectangular sections, forming an 'H' shape. The entire structure is filled with a fine cross-hatched pattern, indicating a mesh or woven material. The corners of the vertical sections are rounded.	<p><b>Sealing Cartons</b> H-shaped sealing cartons</p>
---	--	--

# Contact Us

At Quectel, our aim is to provide timely and comprehensive services to our customers. If you require any assistance, please contact our headquarters:

**Quectel Wireless Solutions Co., Ltd.**

Building 5, Shanghai Business Park Phase III (Area B), No.1016 Tianlin Road, Minhang District, Shanghai 200233, China

Tel: +86 21 5108 6236

Email: [info@quectel.com](mailto:info@quectel.com)

**Or our local offices. For more information, please visit:**

<http://www.quectel.com/support/sales.htm>.

**For technical support, or to report documentation errors, please visit:**

<http://www.quectel.com/support/technical.htm>.

Or email us at: [support@quectel.com](mailto:support@quectel.com).

# Legal Notices

We offer information as a service to you. The provided information is based on your requirements and we make every effort to ensure its quality. You agree that you are responsible for using independent analysis and evaluation in designing intended products, and we provide reference designs for illustrative purposes only. Before using any hardware, software or service guided by this document, please read this notice carefully. Even though we employ commercially reasonable efforts to provide the best possible experience, you hereby acknowledge and agree that this document and related services hereunder are provided to you on an “as available” basis. We may revise or restate this document from time to time at our sole discretion without any prior notice to you.

## Use and Disclosure Restrictions

### License Agreements

Documents and information provided by us shall be kept confidential, unless specific permission is granted. They shall not be accessed or used for any purpose except as expressly provided herein.

### Copyright

Our and third-party products hereunder may contain copyrighted material. Such copyrighted material shall not be copied, reproduced, distributed, merged, published, translated, or modified without prior written consent. We and the third party have exclusive rights over copyrighted material. No license shall be granted or conveyed under any patents, copyrights, trademarks, or service mark rights. To avoid ambiguities, purchasing in any form cannot be deemed as granting a license other than the normal non-exclusive, royalty-free license to use the material. We reserve the right to take legal action for noncompliance with abovementioned requirements, unauthorized use, or other illegal or malicious use of the material.

### Trademarks

Except as otherwise set forth herein, nothing in this document shall be construed as conferring any rights to use any trademark, trade name or name, abbreviation, or counterfeit product thereof owned by Quectel or any third party in advertising, publicity, or other aspects.

### Third-Party Rights

This document may refer to hardware, software and/or documentation owned by one or more third parties (“third-party materials”). Use of such third-party materials shall be governed by all restrictions and obligations applicable thereto.

We make no warranty or representation, either express or implied, regarding the third-party materials, including but not limited to any implied or statutory, warranties of merchantability or fitness for a particular purpose, quiet enjoyment, system integration, information accuracy, and non-infringement of any third-party intellectual property rights with regard to the licensed technology or use thereof. Nothing herein constitutes a representation or warranty by us to either develop, enhance, modify, distribute, market, sell, offer for sale, or otherwise maintain production of any our products or any other hardware, software, device, tool, information, or product. We moreover disclaim any and all warranties arising from the course of dealing or usage of trade.

## Privacy Policy

To implement module functionality, certain device data are uploaded to Quectel's or third-party's servers, including carriers, chipset suppliers or customer-designated servers. Quectel, strictly abiding by the relevant laws and regulations, shall retain, use, disclose or otherwise process relevant data for the purpose of performing the service only or as permitted by applicable laws. Before data interaction with third parties, please be informed of their privacy and data security policy.

## Disclaimer

- a) We acknowledge no liability for any injury or damage arising from the reliance upon the information.
- b) We shall bear no liability resulting from any inaccuracies or omissions, or from the use of the information contained herein.
- c) While we have made every effort to ensure that the functions and features under development are free from errors, it is possible that they could contain errors, inaccuracies, and omissions. Unless otherwise provided by valid agreement, we make no warranties of any kind, either implied or express, and exclude all liability for any loss or damage suffered in connection with the use of features and functions under development, to the maximum extent permitted by law, regardless of whether such loss or damage may have been foreseeable.
- d) We are not responsible for the accessibility, safety, accuracy, availability, legality, or completeness of information, advertising, commercial offers, products, services, and materials on third-party websites and third-party resources.

**Copyright © Quectel Wireless Solutions Co., Ltd. 2025. All rights reserved.**

# Revision History

Version	Date	Author	Note
-	2024-06-05	Mordecai Liu/ Junsen Li/ Rojin Luo/ David Liu/ Rainey Liao	Creation of the document
1.0	2024-06-05	Mordecai Liu/ Junsen Li/ Rojin Luo/ David Liu/ Rainey Liao	First official release
1.1	2024-11-07	Junsen Li	<ol style="list-style-type: none"> <li>Updated block diagram (Chapter 1.3).</li> <li>Added 1561 MHz test data.</li> </ol>
2.0	2025-02-06	Mordecai Liu	Numerous changes were made to this document. It should be read in its entirety.
2.1	2025-06-12	Rojin Luo/ Rainey Liao	<ol style="list-style-type: none"> <li>Updated the antenna image (Cover page).</li> <li>Updated the drawing (Chapter 2).</li> <li>Added antenna installation method (Chapter 4).</li> </ol>
2.2	2025-10-14	Junsen Li	Added LNA gains according to different supply voltages (Chapter 1.1.3).

**QUECTEL**

[www.quectel.com](http://www.quectel.com)