



# Antenna Datasheet

**Product OC** (Antenna Only): YXU00A0AA

**Product OC** (Antenna + Rectangular EVB): YXU00A0EVBAA

**Version:** 2.0

**Date:** 2023-10-20

**Status:** Released

**Product Name:** Wi-Fi SMD Antenna

**Key Features:**

Frequency Band: 2400–2500 MHz; 5150–7125 MHz

Dimensions: 8.0 mm × 6.6 mm × 1.6 mm

Efficiency: Up to 71%

RoHS and Compliant

# Overview

Quectel Wi-Fi antenna covers 2.4 GHz, 5 GHz, and up to 7 GHz bands, fully satisfying customers' requirements for Wi-Fi 5, Wi-Fi 6, and Wi-Fi 6E/Wi-Fi 7. There are various antenna types, including built-in FPC/PCB antenna, ceramic patch antenna, and other external antennas of different shapes or sizes. The antenna performance meets the customers' demands for efficiency, gain, and radiation and ensures the superior experience of the customers' products in use.

# Contents

Overview.....	1
Contents.....	2
<b>1 Specification.....</b>	<b>3</b>
1.1. Electrical.....	3
1.2. Mechanical & Environmental .....	4
<b>2 Drawing .....</b>	<b>5</b>
2.1. Antenna.....	5
2.2. Rectangular EVB.....	7
<b>3 Detailed Performance.....</b>	<b>8</b>
3.1. S-Parameter Test .....	8
3.1.1. VSWR .....	8
3.1.2. Return Loss .....	9
3.2. Radiation Performance Test.....	10
3.2.1. Efficiency.....	10
3.2.2. Average Gain .....	11
3.2.3. Peak Gain .....	12
3.3.4. 3D & 2D Radiation Pattern .....	13
<b>4 Schematic Symbol and Pin Definition .....</b>	<b>16</b>
<b>5 Transmission Line .....</b>	<b>17</b>
<b>6 Recommended PCB Layout.....</b>	<b>18</b>
<b>7 Matching Circuit.....</b>	<b>19</b>
7.1. 60 × 50 mm EVB.....	19
<b>8 Soldering Temperature.....</b>	<b>20</b>
<b>9 Reflow Profile .....</b>	<b>21</b>
<b>10 Packaging .....</b>	<b>22</b>
<b>Contact Us.....</b>	<b>24</b>
<b>Legal Notices .....</b>	<b>25</b>
<b>Revision History .....</b>	<b>27</b>

# 1 Specification

Test Condition: Assembled on 60 × 50 mm EVB

## 1.1. Electrical

Electrical	
Frequency Range	2400–2500 MHz; 5150–7125 MHz
Impedance	50 Ω
Polarization	Linear
Radiation Pattern	Omni-directional

Specification	Band	Band	Wi-Fi 2.4G	Wi-Fi 5G	Wi-Fi 6e
		Freq. (MHz)	2400–2500	5150–5850	5925–7125
Max. VSWR	FS		2.1	2.4	3.3
Max. Return Loss (dB)	FS		-9.0	-7.6	-5.4
AVG Eff. (%)	FS		54.4	67.0	50.8
AVG Gain (dB)	FS		-2.6	-1.7	-3.0
Max. Peak Gain (dBi)	FS		0.5	2.4	3.6
VSWR	FS		≤ 3.3		
Return Loss	FS		≤ -5.4 dB		
Peak Gain	FS		≤ 3.6 dBi		

## 1.2. Mechanical & Environmental

Mechanical	
Antenna Size	8.0 × 6.6 × 1.6 mm
Antenna Material & Color	PCB & Black
Antenna Weight	Typ. 0.18 g
Mounting Type	SMD
Recommended EVB Size	60 × 50 × 1.6mm
Environmental	
Operation Temperature	-40 °C to +85 °C
Storage Temperature	-40 °C to +85 °C
RoHS & Compliant	Yes

# 2 Drawing

## 2.1. Antenna

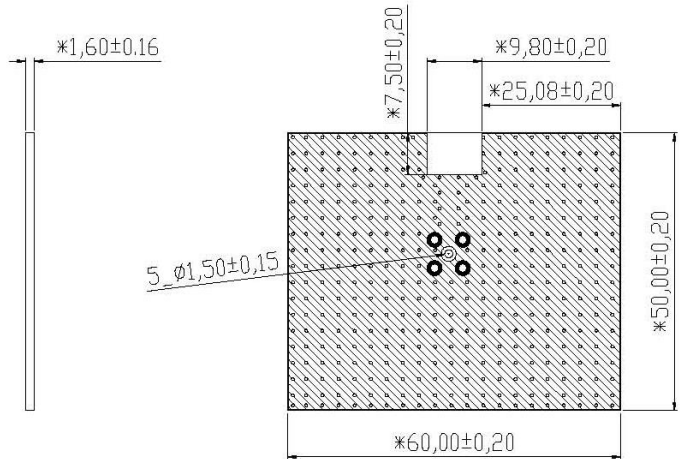
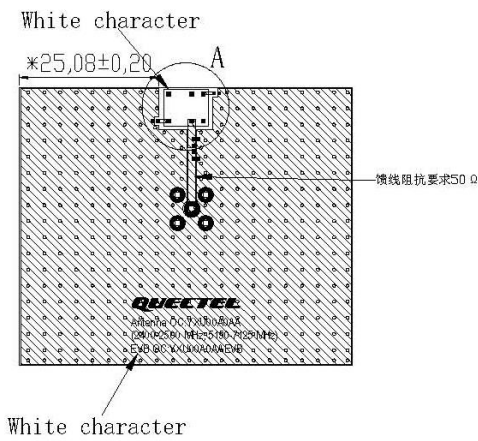
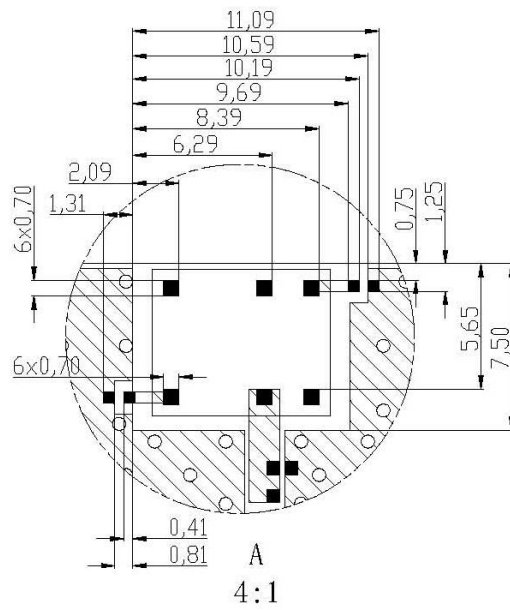

ROHS

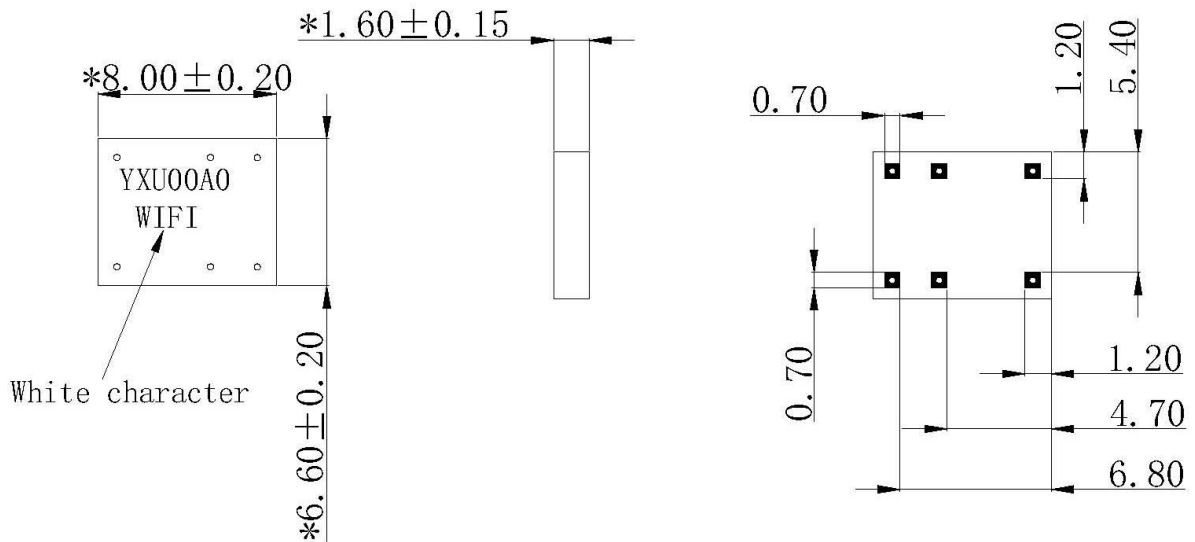

Name	Material	Brand	QTY	Model
Antenna	FR4 1.6t	Quectel	1	YXU00A0AA
PCB	FR4 1.6t	Quectel	1	YXU00A0AA EVB
SMA Female Connector	Brass	Quectel	1	-
1.8 nH	Ceramics	Murata	1	LQG15HS1N8B02D
1.5 pF	Ceramics	Murata	1	GJM1555C1H1R5BB01
0Ω	Ceramics	Murata	1	-

## 2.2. Rectangular EVB

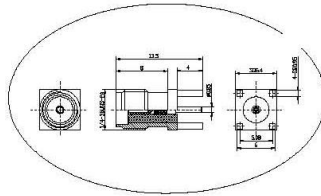

Frequency range: 0~8 GHz

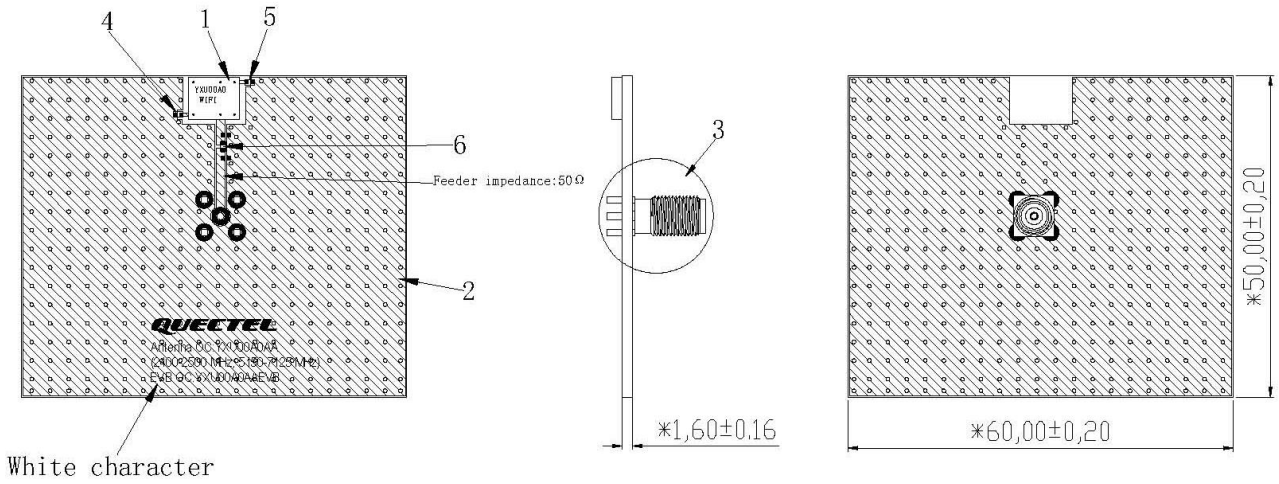

# 3 Detailed Performance

## 3.1. S-Parameter Test

### 3.1.1. VSWR

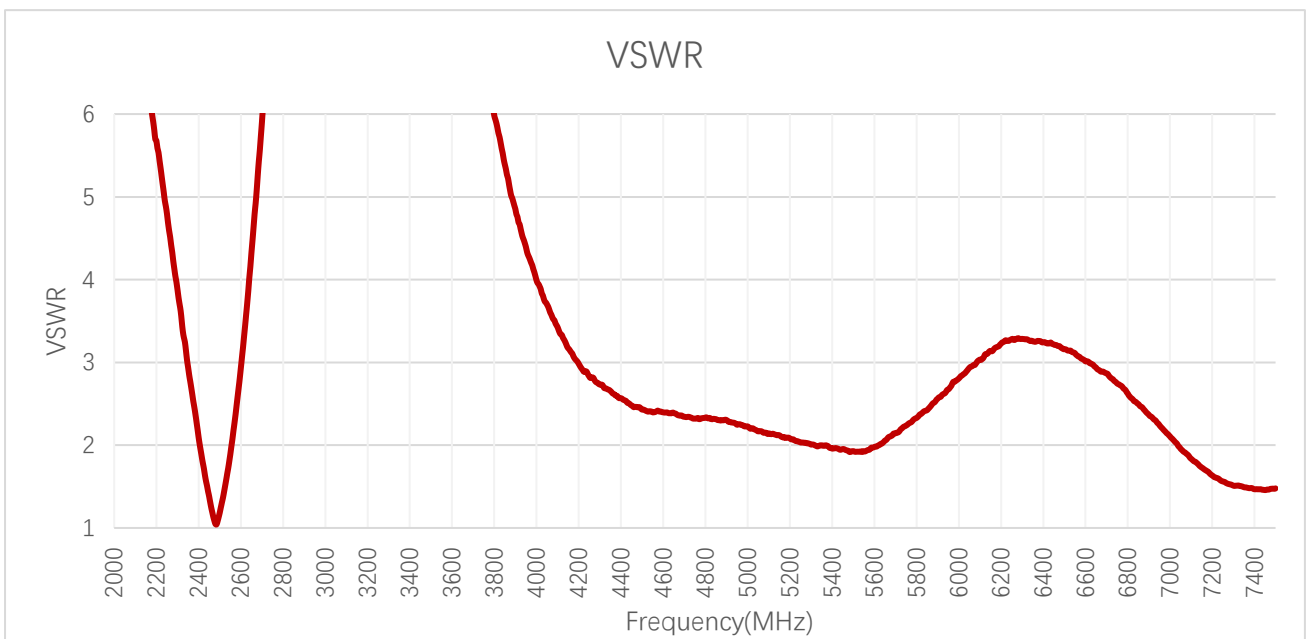

**VSWR**

Frequency (MHz)	2400	2450	2500	5150	5500	5850	5925	6325	6725	7125
<b>VSWR</b>	2.1	1.4	1.2	2.1	1.9	2.4	2.6	3.3	2.8	1.8

**3.1.2. Return Loss**

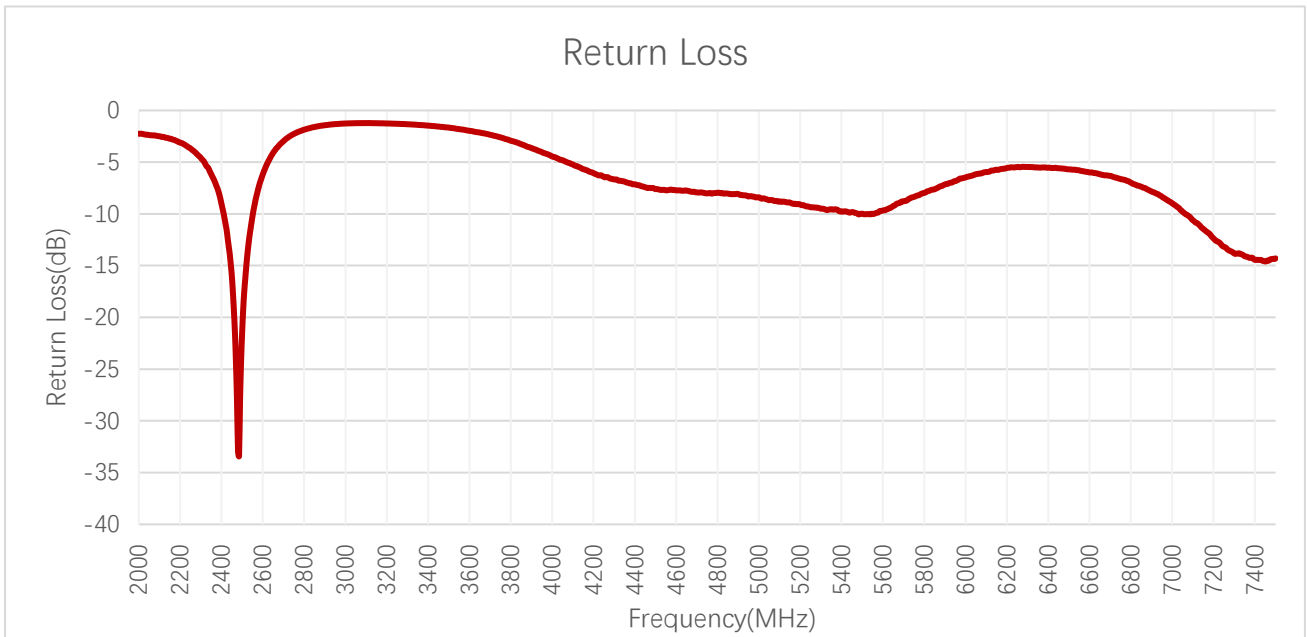

**Return Loss (dB)**

Frequency (MHz)	2400	2450	2500	5150	5500	5850	5925	6325	6725	7125
Return Loss (dB)	-9.0	-16.0	-21.5	-8.9	-10.0	-7.6	-7.0	-5.5	-6.5	-11.0

### 3.2. Radiation Performance Test

#### 3.2.1. Efficiency

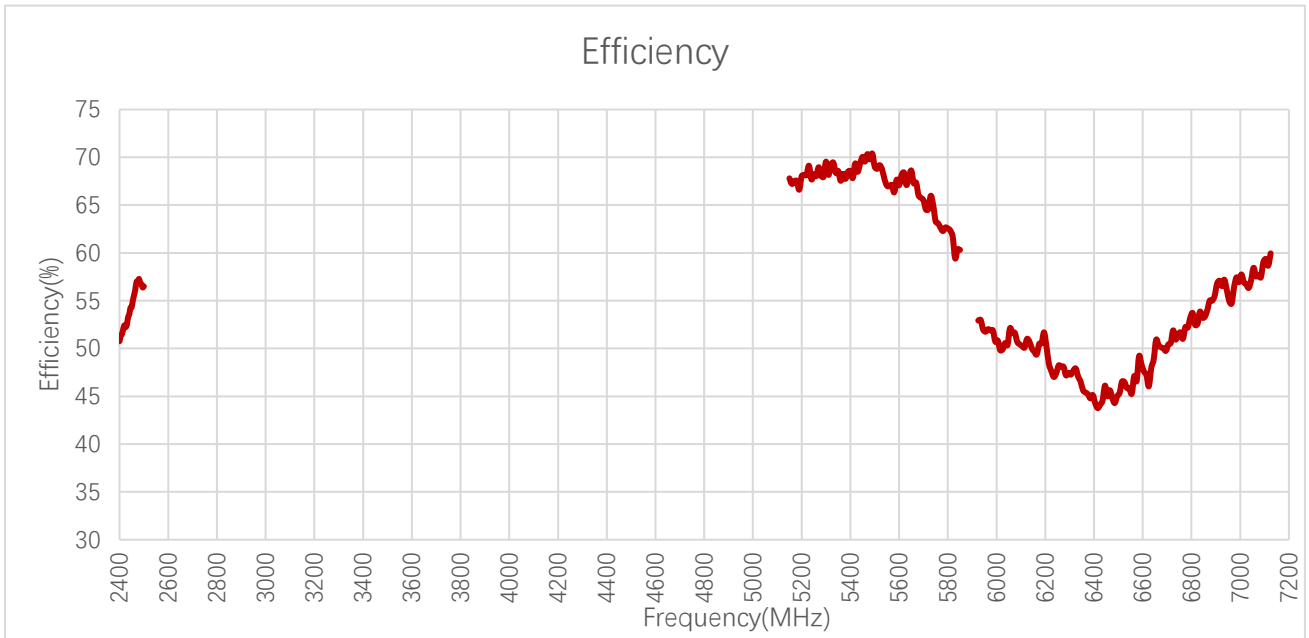

**Efficiency (%)**

Frequency (MHz)	2400	2450	2500	5150	5500	5850	5925	6325	6725	7125
Efficiency (%)	50.8	54.3	56.5	67.8	69.0	60.3	52.9	47.9	51.9	60.0

**3.2.2. Average Gain**

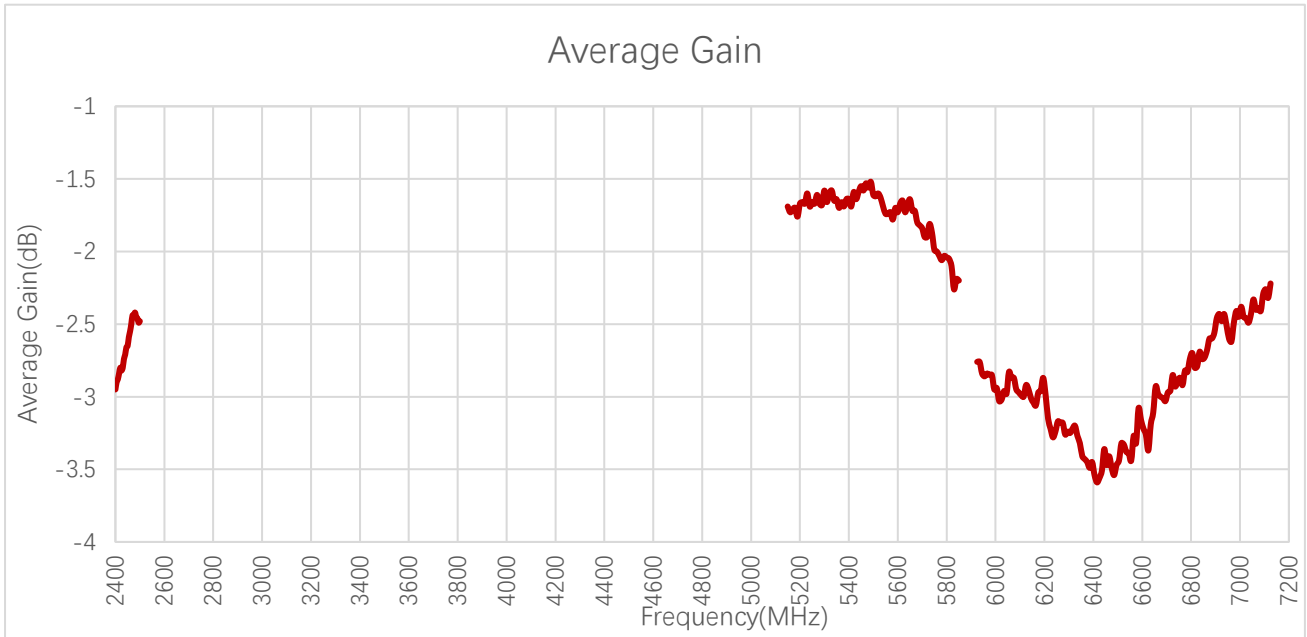

**Average Gain (dB)**

Frequency (MHz)	2400	2450	2500	5150	5500	5850	5925	6325	6725	7125
Average Gain (dB)	-3.0	-2.7	-2.5	-1.7	-1.6	-2.2	-2.8	-3.2	-2.9	-2.2

**3.2.3. Peak Gain**

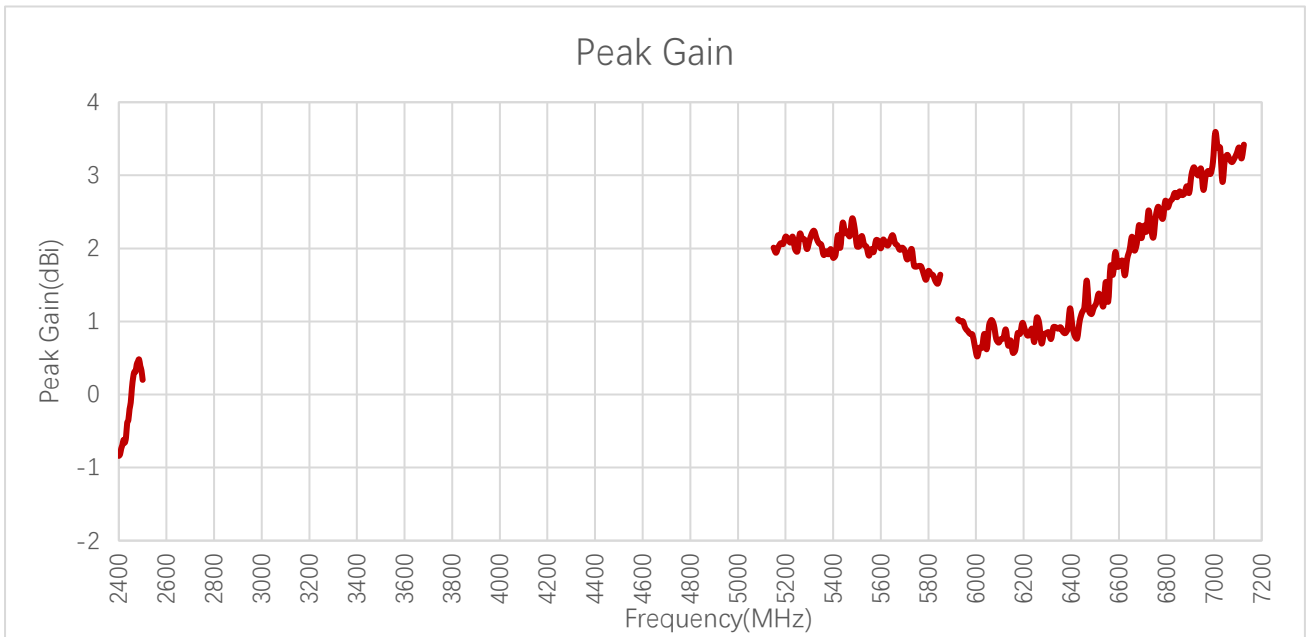

**Peak Gain (dBi)**

Frequency (MHz)	2400	2450	2500	5150	5500	5850	5925	6325	6725	7125
Peak Gain (dBi)	-0.8	-0.1	0.2	2.0	2.0	1.6	1.0	0.9	2.5	3.4

### 3.3.4. 3D & 2D Radiation Pattern

- Test Status: Assembled on 60 × 50 mm EVB

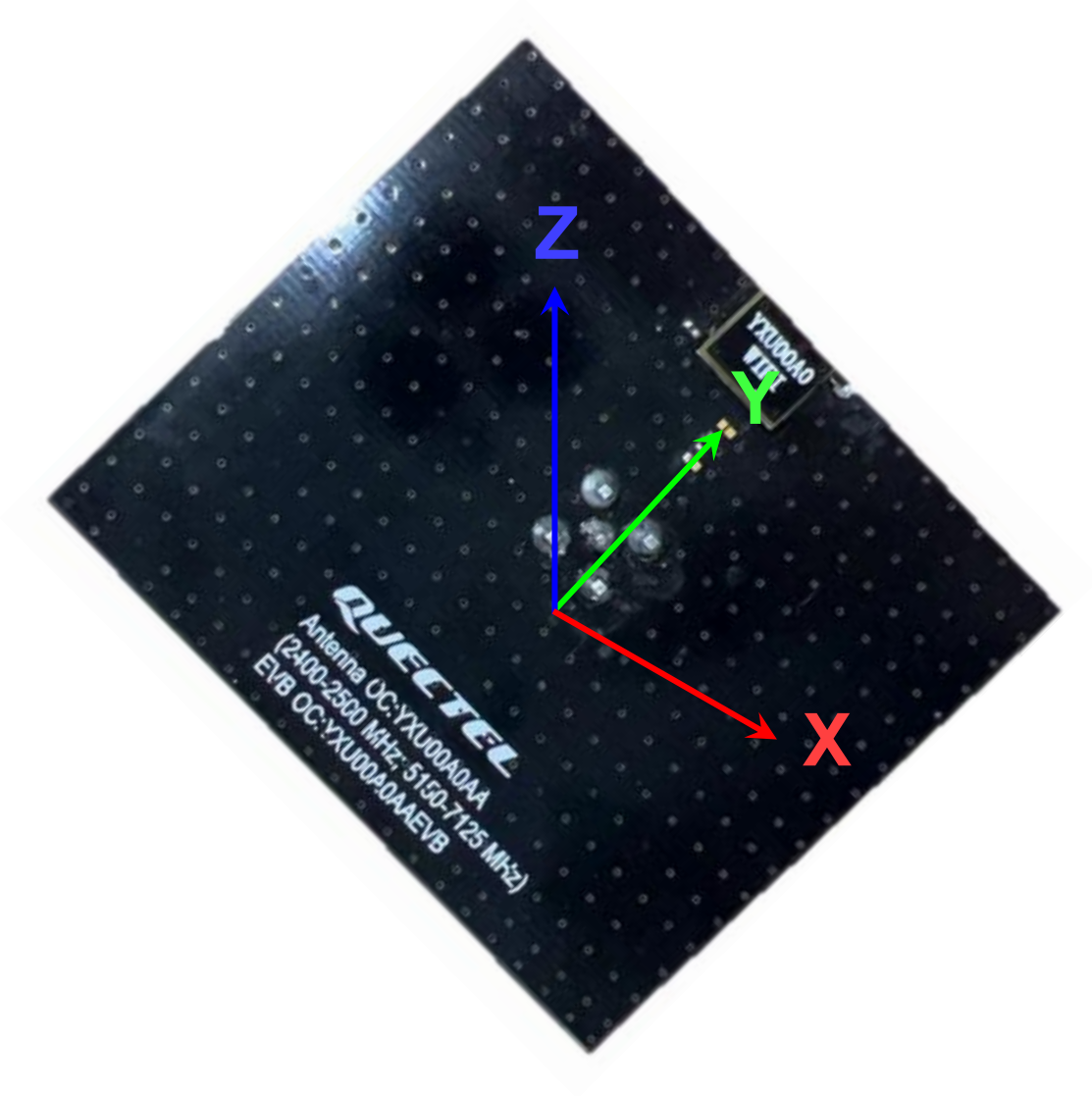

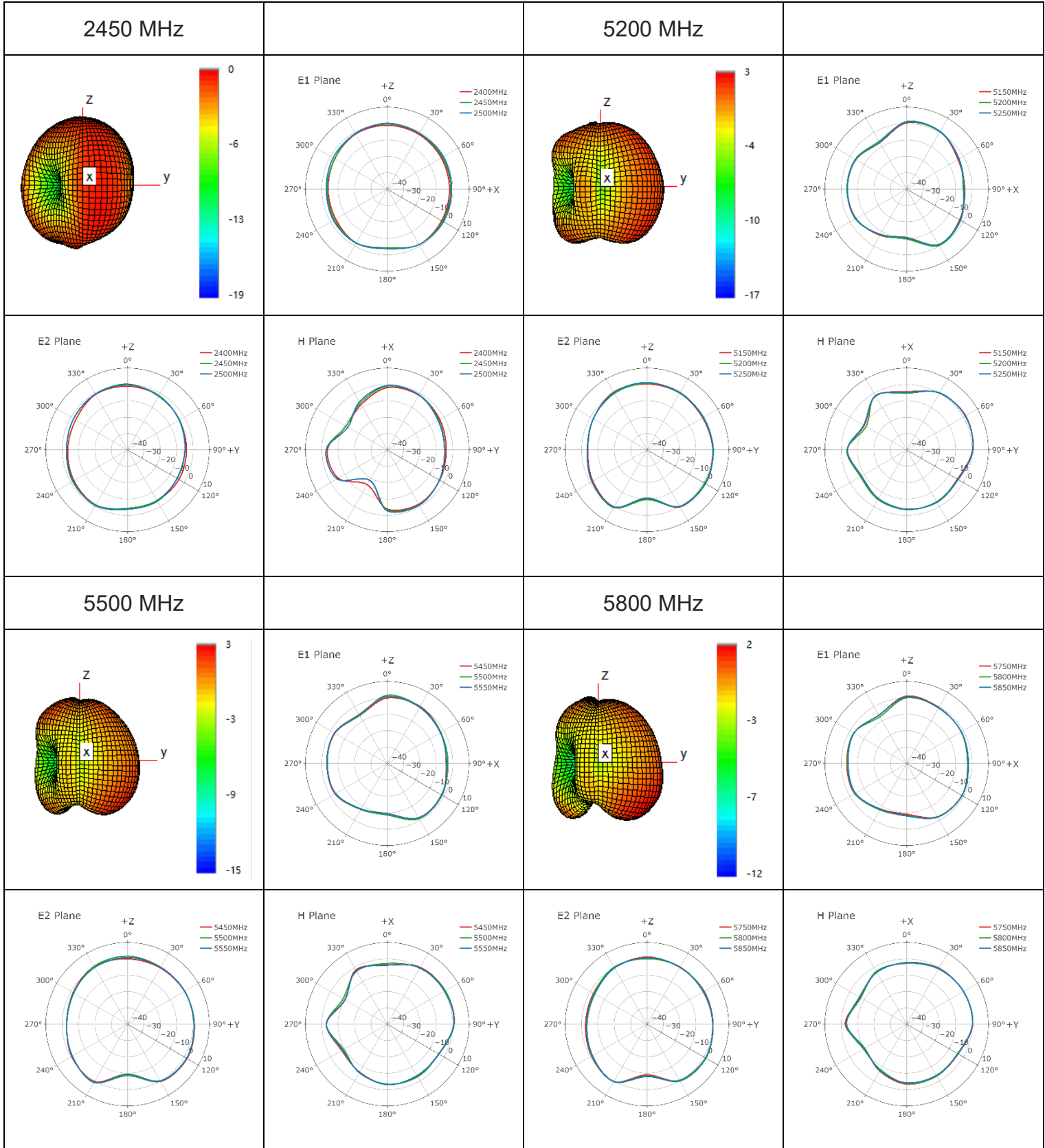

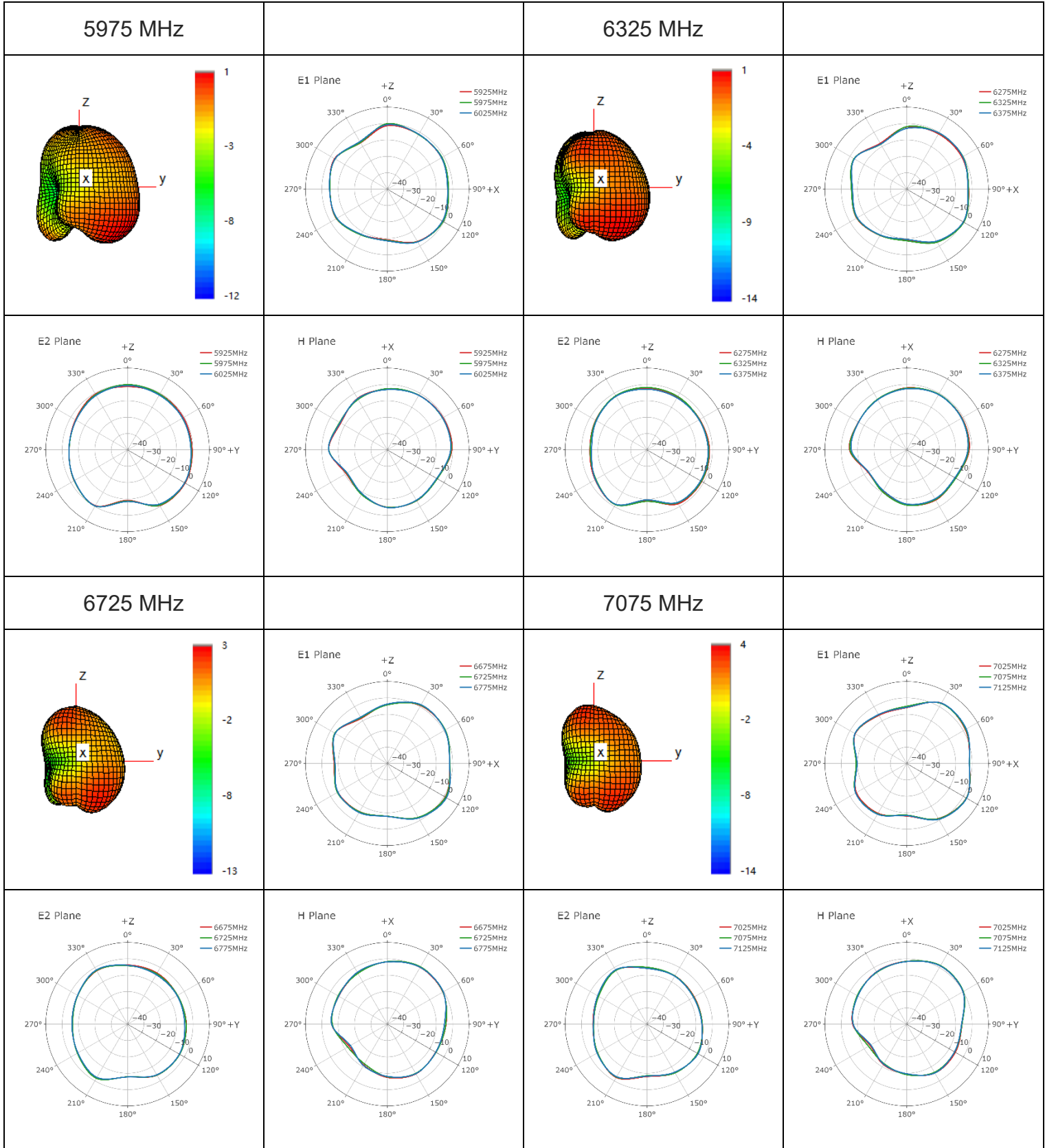

# 4 Schematic Symbol and Pin Definition

- The pin assignment for the antenna is as follows.
- The antenna has 6 pins and only three work.
- All other pins are designed for mechanical strength.

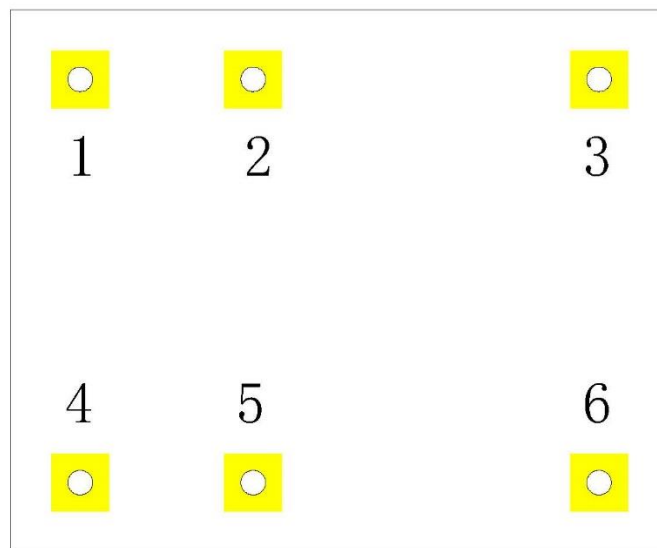

Pin No.	Description
1, 6	Antenna Tuning
2, 3, 4	Not used (Mechanical only)
5	FEED

## 5 Transmission Line

The characteristic impedance of all transmission lines shall be designed as 50  $\Omega$ .

- The length of the transmission lines should be kept as short as possible.
- Any other part of the RF system, such as transceiver, power amplifiers, etc., shall also be designed with an impedance of 50  $\Omega$ .

Once the material for the PCB has been chosen (PCB thickness and dielectric constant), a coplanar transmission line can easily be designed using any of the commercial software packages for transmission line design. For the chosen PCB thickness, copper thickness and substrate dielectric constant, the program will calculate the appropriate transmission line width and gaps on either side of the track so the characteristic impedance of the coplanar transmission is 50  $\Omega$ .

# 6 Recommended PCB Layout

The host PCB must be designed using the PCB footprint shown with the correct clearances. An example of the PCB layout shows the antenna footprint. Please note this clearance area is critical to the performance of the antenna and must be applied through all layers of the PCB.

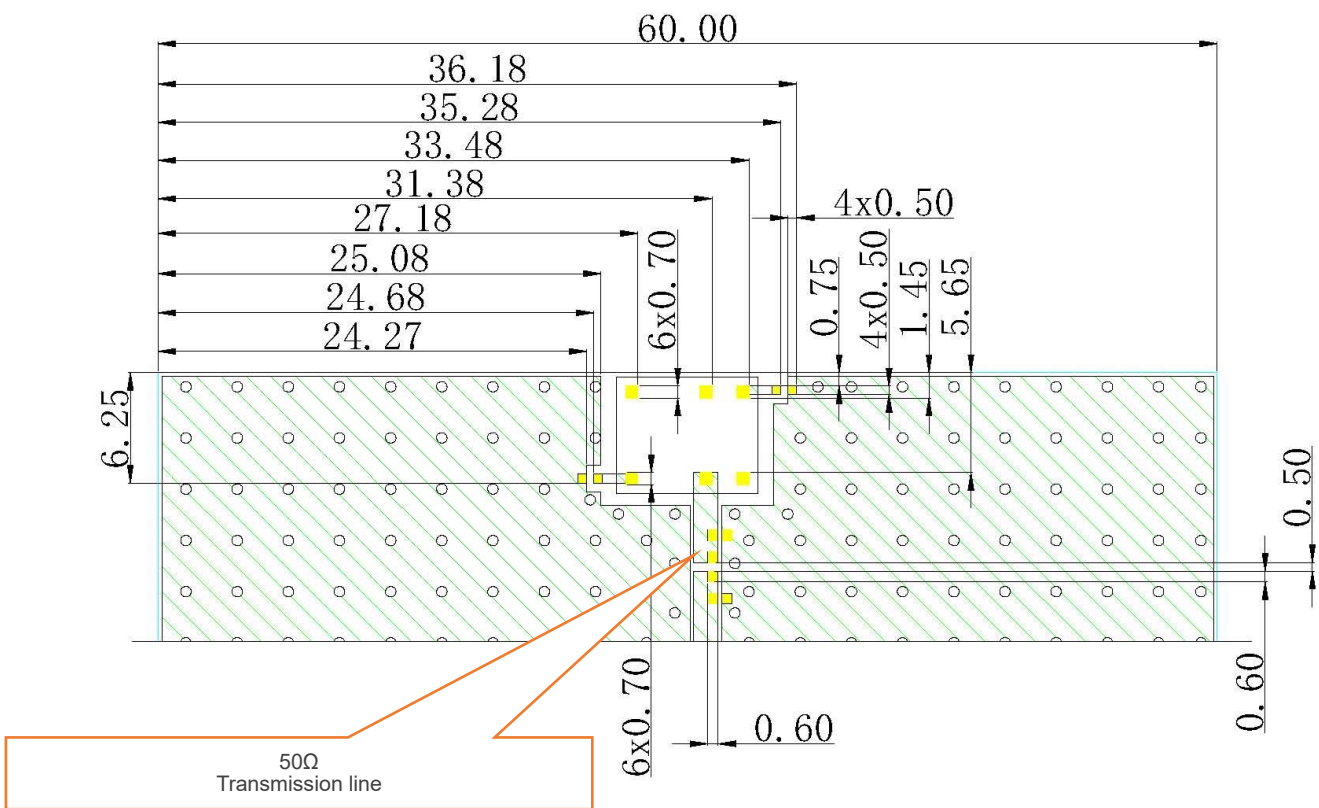

All dimensions in (mm)

# 7 Matching Circuit

## 7.1. 60 × 50 mm EVB

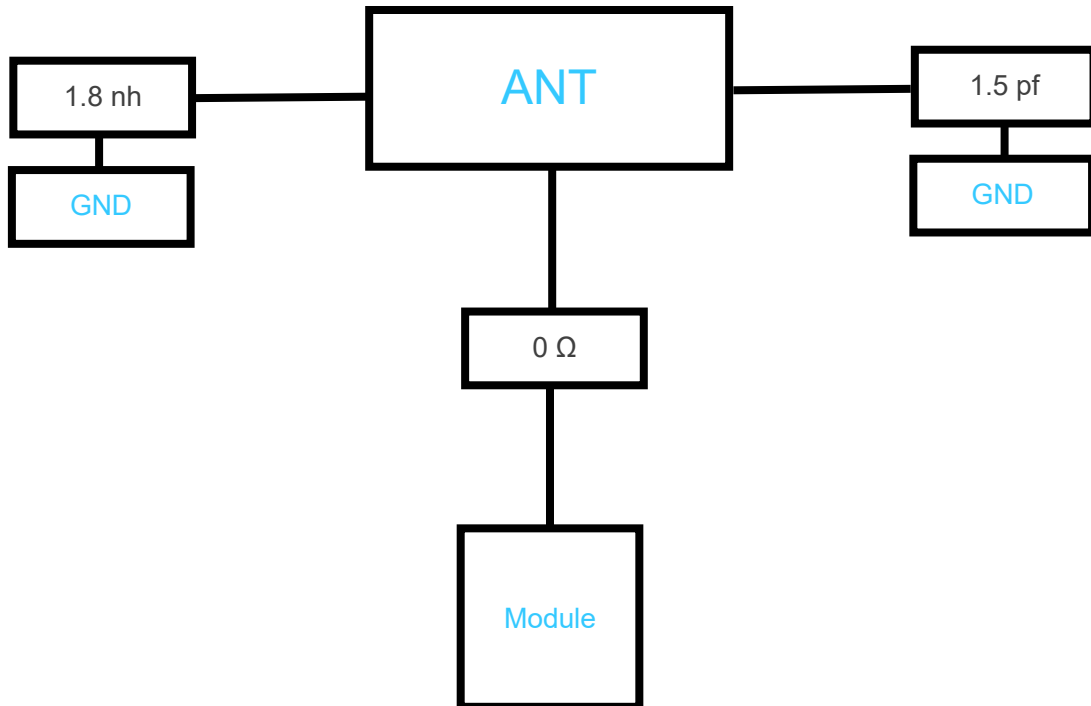



## 8 Soldering Temperature

Phase	Profile Features	PB-Free Assembly
RAMP-UP	Avg. Ramp-up Rate (T <sub>smax</sub> to T <sub>p</sub> )	3 °C/second (Max.)
PREHEAT	Temperature Min (T <sub>smin</sub> ) Temperature Max (T <sub>smax</sub> ) Time (t <sub>smin</sub> to t <sub>smax</sub> )	150 °C 190 °C 110 seconds (Max.)
REFLOW	Temperature (TL) Total Time above TL (tl)	220 °C 90 seconds (Max.)
PEAK	Temperature (T <sub>p</sub> )	230–250 °C
RAMP-DOWN	Rate	-1 °C/second (Max.)

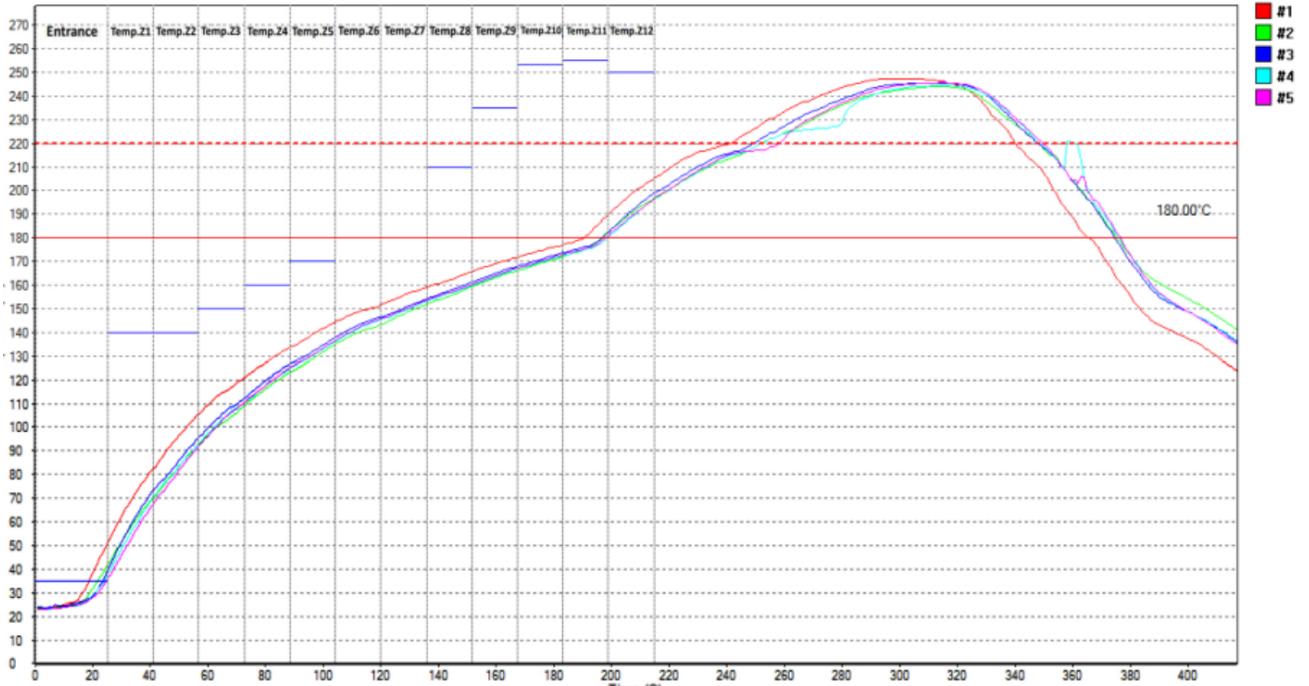
# 9 Reflow Profile

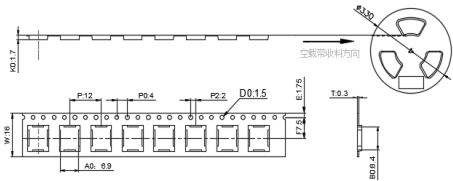
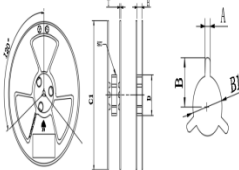

# 10 Packaging

Step	Packaging Picture / 2D Picture	Description																																																																																	
1		<p>Each carrier tape packs 3000 products.</p> <p>Place desiccant in vacuum package and vacuum.</p> <p>(3000 Antennas / Reel)</p>																																																																																	
2	<table border="1" data-bbox="323 1104 579 1350"> <thead> <tr> <th></th> <th colspan="8">V</th> </tr> <tr> <th>SPEC</th> <th>12</th> <th>18</th> <th>24</th> <th>32</th> <th>44</th> <th>56</th> <th>72</th> <th>88</th> </tr> </thead> <tbody> <tr> <td>C1±0</td> <td>330</td> <td>330</td> <td>330</td> <td>330</td> <td>330</td> <td>330</td> <td>330</td> <td>330</td> </tr> <tr> <td>H±0.5</td> <td>12.5</td> <td>16.5</td> <td>24.5</td> <td>32.5</td> <td>44.5</td> <td>56.5</td> <td>72.5</td> <td>88.5</td> </tr> <tr> <td>A±0.3</td> <td>2.3</td> <td>2.3</td> <td>2.3</td> <td>2.3</td> <td>2.3</td> <td>2.3</td> <td>2.3</td> <td>2.3</td> </tr> <tr> <td>B±0.3</td> <td>10.75</td> <td>10.75</td> <td>10.75</td> <td>10.75</td> <td>10.75</td> <td>10.75</td> <td>10.75</td> <td>10.75</td> </tr> <tr> <td>B1±0.2</td> <td>φ13.0</td> <td>φ13.0</td> <td>φ13.0</td> <td>φ13.0</td> <td>φ13.0</td> <td>φ13.0</td> <td>φ13.0</td> <td>φ13.0</td> </tr> <tr> <td>T±0.2</td> <td>2.0</td> <td>2.0</td> <td>2.0</td> <td>2.0</td> <td>2.0</td> <td>2.0</td> <td>2.0</td> <td>2.0</td> </tr> <tr> <td>D±1</td> <td>φ100</td> <td>φ100</td> <td>φ100</td> <td>φ100</td> <td>φ100</td> <td>φ100</td> <td>φ100</td> <td>φ100</td> </tr> </tbody> </table> 		V								SPEC	12	18	24	32	44	56	72	88	C1±0	330	330	330	330	330	330	330	330	H±0.5	12.5	16.5	24.5	32.5	44.5	56.5	72.5	88.5	A±0.3	2.3	2.3	2.3	2.3	2.3	2.3	2.3	2.3	B±0.3	10.75	10.75	10.75	10.75	10.75	10.75	10.75	10.75	B1±0.2	φ13.0	φ13.0	φ13.0	φ13.0	φ13.0	φ13.0	φ13.0	φ13.0	T±0.2	2.0	2.0	2.0	2.0	2.0	2.0	2.0	2.0	D±1	φ100	φ100	φ100	φ100	φ100	φ100	φ100	φ100	<p>Put the packaged products into the pizza box.</p> <p>Pack 2 carrier tapes on each pizza box.</p> <p>(6000 Antennas / Pizza Box)</p>
	V																																																																																		
SPEC	12	18	24	32	44	56	72	88																																																																											
C1±0	330	330	330	330	330	330	330	330																																																																											
H±0.5	12.5	16.5	24.5	32.5	44.5	56.5	72.5	88.5																																																																											
A±0.3	2.3	2.3	2.3	2.3	2.3	2.3	2.3	2.3																																																																											
B±0.3	10.75	10.75	10.75	10.75	10.75	10.75	10.75	10.75																																																																											
B1±0.2	φ13.0	φ13.0	φ13.0	φ13.0	φ13.0	φ13.0	φ13.0	φ13.0																																																																											
T±0.2	2.0	2.0	2.0	2.0	2.0	2.0	2.0	2.0																																																																											
D±1	φ100	φ100	φ100	φ100	φ100	φ100	φ100	φ100																																																																											
3		<p>One box contains 2 inner boxes, a total of 12000 products.</p> <p>(2 Pizza Boxes / Carton Box)</p> <p>(12000 Antennas / Carton Box)</p> <p>Estimated quantity</p> <p>Products that cannot fill the entire carton box are packed in a suitable size carton box.</p> <p><u>Carton Size:</u></p>																																																																																	

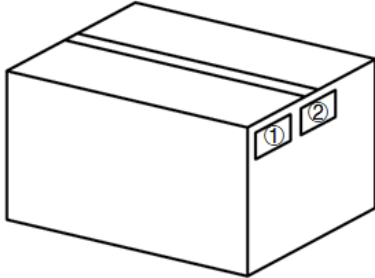
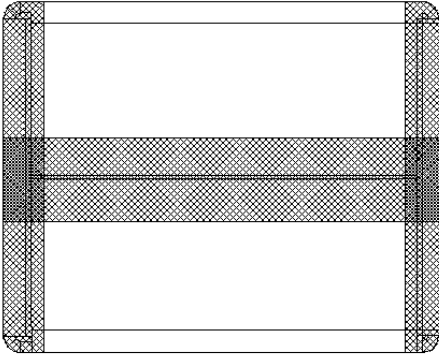
		<u>L × W × H = 390 × 390 × 160 mm</u>
4		<p><b>Position for Attaching Labels</b></p> <ul style="list-style-type: none"> <li>① Carton Label</li> <li>② Quality Label</li> </ul>
5		<p><b>Sealing Cartons</b></p> <p>“I” type sealing cartons</p>
Note	The initial packaging method described above is for reference only, and the final actual packaging method shall be subject to the actual shipping packaging.	

## Contact Us

At Quectel, our aim is to provide timely and comprehensive services to our customers. If you require any assistance, please contact our headquarters:

**Quectel Wireless Solutions Co., Ltd.**

Building 5, Shanghai Business Park Phase III (Area B), No.1016 Tianlin Road, Minhang District, Shanghai 200233, China

Tel: +86 21 5108 6236

Email: [info@quectel.com](mailto:info@quectel.com)

**Or our local offices. For more information, please visit:**

<http://www.quectel.com/support/sales.htm>.

**For technical support, or to report documentation errors, please visit:**

<http://www.quectel.com/support/technical.htm>.

Or email us at: [support@quectel.com](mailto:support@quectel.com).

# Legal Notices

We offer information as a service to you. The provided information is based on your requirements and we make every effort to ensure its quality. You agree that you are responsible for using independent analysis and evaluation in designing intended products, and we provide reference designs for illustrative purposes only. Before using any hardware, software or service guided by this document, please read this notice carefully. Even though we employ commercially reasonable efforts to provide the best possible experience, you hereby acknowledge and agree that this document and related services hereunder are provided to you on an “as available” basis. We may revise or restate this document from time to time at our sole discretion without any prior notice to you.

## Use and Disclosure Restrictions

### License Agreements

Documents and information provided by us shall be kept confidential, unless specific permission is granted. They shall not be accessed or used for any purpose except as expressly provided herein.

### Copyright

Our and third-party products hereunder may contain copyrighted material. Such copyrighted material shall not be copied, reproduced, distributed, merged, published, translated, or modified without prior written consent. We and the third party have exclusive rights over copyrighted material. No license shall be granted or conveyed under any patents, copyrights, trademarks, or service mark rights. To avoid ambiguities, purchasing in any form cannot be deemed as granting a license other than the normal non-exclusive, royalty-free license to use the material. We reserve the right to take legal action for noncompliance with abovementioned requirements, unauthorized use, or other illegal or malicious use of the material.

### Trademarks

Except as otherwise set forth herein, nothing in this document shall be construed as conferring any rights to use any trademark, trade name or name, abbreviation, or counterfeit product thereof owned by Quectel or any third party in advertising, publicity, or other aspects.

### Third-Party Rights

This document may refer to hardware, software and/or documentation owned by one or more third parties (“third-party materials”). Use of such third-party materials shall be governed by all restrictions and obligations applicable thereto.

We make no warranty or representation, either express or implied, regarding the third-party materials, including but not limited to any implied or statutory, warranties of merchantability or fitness for a particular purpose, quiet enjoyment, system integration, information accuracy, and non-infringement of any third-party intellectual property rights with regard to the licensed technology or use thereof. Nothing herein constitutes a representation or warranty by us to either develop, enhance, modify, distribute, market, sell, offer for sale, or otherwise maintain production of any our products or any other hardware, software, device, tool, information, or product. We moreover disclaim any and all warranties arising from the course of dealing or usage of trade.

## Privacy Policy

To implement module functionality, certain device data are uploaded to Quectel's or third-party's servers, including carriers, chipset suppliers or customer-designated servers. Quectel, strictly abiding by the relevant laws and regulations, shall retain, use, disclose or otherwise process relevant data for the purpose of performing the service only or as permitted by applicable laws. Before data interaction with third parties, please be informed of their privacy and data security policy.

## Disclaimer

- a) We acknowledge no liability for any injury or damage arising from the reliance upon the information.
- b) We shall bear no liability resulting from any inaccuracies or omissions, or from the use of the information contained herein.
- c) While we have made every effort to ensure that the functions and features under
- d) development are free from errors, it is possible that they could contain errors, inaccuracies, and omissions. Unless otherwise provided by valid agreement, we make no warranties of any kind, either implied or express, and exclude all liability for any loss or damage suffered in connection with the use of features and functions under development, to the maximum extent permitted by law, regardless of whether such loss or damage may have been foreseeable.
- e) We are not responsible for the accessibility, safety, accuracy, availability, legality, or completeness of information, advertising, commercial offers, products, services, and materials on third-party websites and third-party resources.

**Copyright © Quectel Wireless Solutions Co., Ltd. 2023. All rights reserved.**

# Revision History

Version	Date	Author	Note
-	2022-01-19	Christopher Yao	Creation of the document
1.0	2022-02-11	Toby Wang	First official release
1.1	2023-06-13	Toby Wang	Added Chapter 6 and updated Chapter 5.
2.0	2023-10-20	Christopher YAO/ Toby WANG/ David LIU/ Vinnie LIU	Updated the template and all test data.

**QUECTEL**

[www.quectel.com](http://www.quectel.com)