

Antenna Datasheet

Product OC: YFGA245E3AM

Version: 1.3

Date: 2025-10-27

Status: Released

Product Name: GNSS L1&L5 Screw Mount Ceramic Patch + Cable
Active Embedded Antenna

Key Features:

Frequency Band: 1164–1189 MHz, 1559–1606 MHz

Dimensions: 59 mm × 59 mm × 14.2 mm

RoHS Compliant

LNA Gain: 17 ±3 dB

Overview

The Quectel YFGA245E3AM is a high-performance GNSS active embedded antenna designed for precise positioning. Operating across frequency bands 1164–1189 MHz and 1559–1606 MHz, it supports multiple GNSS systems including GPS, GLONASS, Galileo, BDS, QZSS, and IRNSS.

With dimensions 59 mm × 59 mm × 14.2 mm and a screw-mount design, it combines a ceramic patch, PCB, and 100mm black RF cable with an IPEX MHF 1 connector, weighing typically 74.6 g.

Featuring RHCP polarization and a directional radiation pattern, it delivers strong performance: 17 ± 3 dB LNA gain, ≤ 2.5 dB noise figure, and up to 74 % efficiency (at 1575 MHz). It ensures reliable operation in harsh environments, with a -40 °C to $+85$ °C temperature range, and is RoHS compliant. Ideal for applications demanding accurate, stable positioning.

Quectel provides comprehensive antenna design support such as simulation, testing and manufacturing for custom antenna solutions to meet your specific application needs. We have regional R & D centers to offer quick response to meet your requirements. Please contact our sales & FAEs if you have any requests.

Contents

Overview	1
Contents	2
1 Specification	3
1.1. Electrical.....	3
1.2. Mechanical & Environmental	4
1.3. Block Diagram (Active Antenna).....	5
1.4. Supported GNSS Frequency Bands.....	6
2 Drawing	8
3 Detailed Performance	9
3.1. S-Parameter Test	9
3.1.1. VSWR.....	9
3.1.2. Return Loss	10
3.1.3. GNSS LNA Gain.....	11
3.1.4. Noise Figure	12
3.2. Radiation Performance Test.....	13
3.2.1. Efficiency	13
3.2.2. Peak Gain.....	14
3.2.3. Axial Ratio	15
3.2.4. 2D RHCP and LHCP Gain	16
3.2.5. 3D & 2D Radiation Pattern.....	17
4 Packaging	19
Contact Us	21
Legal Notices	22
Revision History	24

1 Specification

Test Condition: Free Space

1.1. Electrical

Electrical	
Frequency Range	1164–1189 MHz, 1559–1606 MHz
Impedance	50 Ω
Polarization	RHCP
Radiation Pattern	Directional

Frequency (MHz)	Band	GPS L5	GALILEO	GPS L2	GLONASS	BDS B3	BDS B1I	GPS L1	GLONASS
		GALILEO E5a BDS B2a- B2I QZSS L5 IRNSS L5	GALILEO E5b BDS B2b	QZSS L2C	G2			E1 BDS B1C QZSS L1	G1
		1176	1207	1227	1248	1268	1561	1575	1602
VSWR		1.13	-	-	-	-	1.41	1.52	1.68
Return Loss (dB)		-24.2	-	-	-	-	-15.3	-13.6	-11.8
Efficiency (%)		54.9	-	-	-	-	62	74	48.9
Peak Gain (dBi)		1.9	-	-	-	-	2.68	3.53	2.39
Axial Ratio (dB)		2.17	-	-	-	-	1.4	1.4	0.88

LNA Electrical	
LNA Gain	17 ±3 dB @ 3–5 V 15 ±3 dB @ 1.8 V
Noise Figure	≤ 2.5 dB
Output VSWR	< 2.0
Filter Out-of-Band Attenuation	≥ 40 dB f0 ±100 MHz f0 (1176 MHz, 1580 MHz)
Working Voltage	1.8–5 V
Working Current	16.5 ±4 mA @ 3–5 V 11.5 ±3 Ma @ 1.8 V
Impedance	50 Ω

1.2. Mechanical & Environmental

Mechanical	
Antenna Dimensions	59 mm × 59 mm × 14.2 mm
Material	PCB + Ceramic + RF Cable
Cable Type & Color & Length	Φ 1.13 & Black & 100 mm
Connector Type	IPEX MHF 1
Mounting Type	Screw
Weight	Typ. 74.6 g
Environmental	
Operation Temperature	-40 °C to +85 °C
Storage Temperature	-40 °C to +85 °C
RoHS & REACH Compliant	Yes

1.3. Block Diagram (Active Antenna)

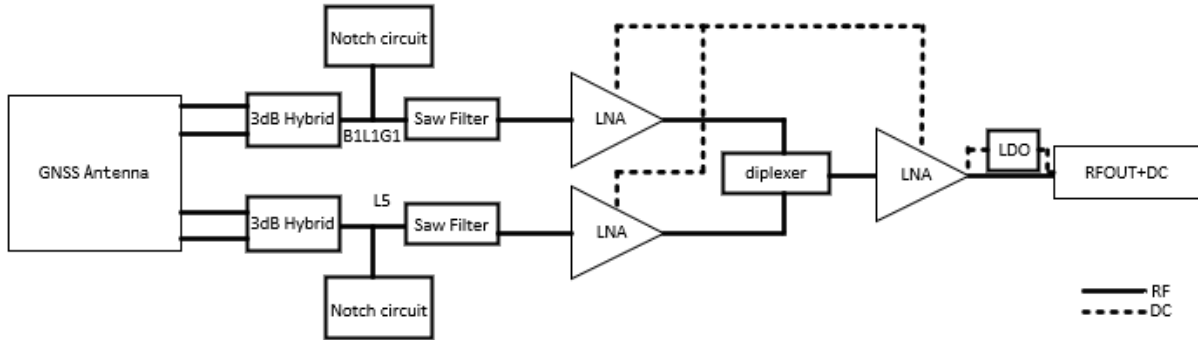

1.4. Supported GNSS Frequency Bands

GNSS Frequency Bands (MHz)					
GPS	L1 Centre 1575.42 (1565–1586)	L2 Centre 1227.6 (1217–1238)	L5 Centre 1176.45 (1164–1189)		
	√	-	√		
GLONASS	G1-L10C-L10F Centre 1601 (1595–1606)	G2-L20C-L20F Centre 1248.06 (1241–1255)	G3-L30C Centre 1202.025 (1189–1213)		
	√	-	-		
GALILEO	E1 Centre 1575.42 (1563–1588)	E5a Centre 1176.45 (1166–1187)	E5b Centre 1207.14 (1197–1218)	E6 Centre 1278.75 (1258–1300)	
	√	√	-	-	
BDS	B1I Centre 1561.098 (1559–1564)	B1C (BDS-3) Centre 1575.42 (1559–1592)	B2a Centre 1176.45 (1166–1187)	B2b-B2I Centre 1207.14 (1197–1217)	B3 Centre 1268.52 (1258–1279)
	√	√	√	-	-
QZSS	L1 Centre 1575.42 (1573–1578)	L2C Centre 1227.6 (1226–1229)	L5 Centre 1176.45 (1166–1187)	L6 Centre 1278.75 (1257–1300)	
	√	-	√	-	
IRNSS	L5 Centre 1176.45 (1164–1189)				
	√				

GNSS Bands and Constellations

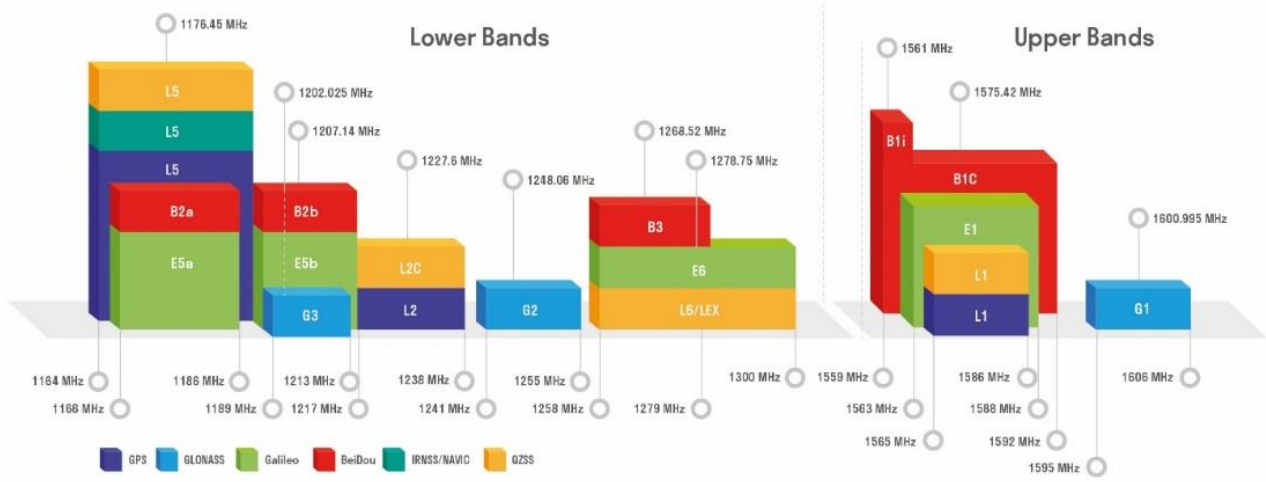

2 Drawing

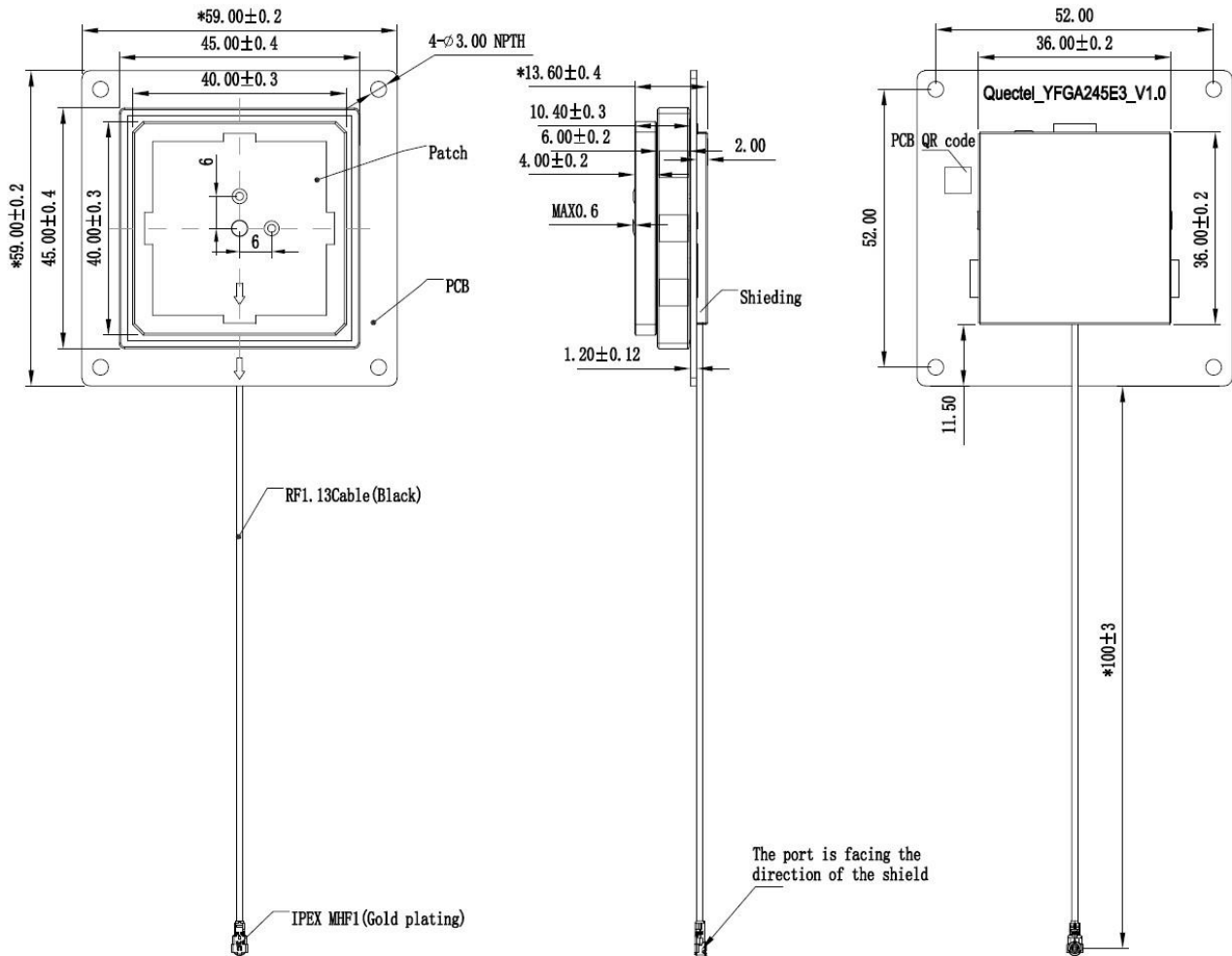

3 Detailed Performance

3.1. S-Parameter Test

3.1.1. VSWR

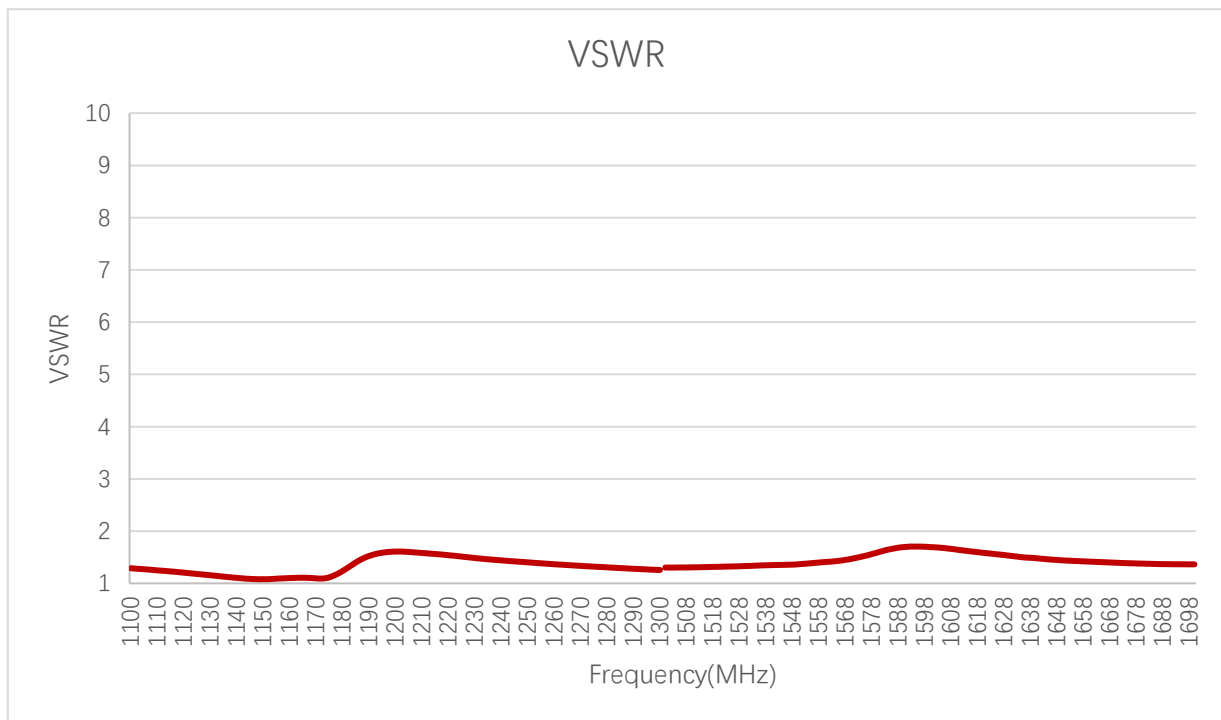

VSWR

Frequency (MHz)	1176	1207	1227	1248	1268	1561	1575	1602
VSWR	1.13	-	-	-	-	1.41	1.52	1.68

3.1.2. Return Loss

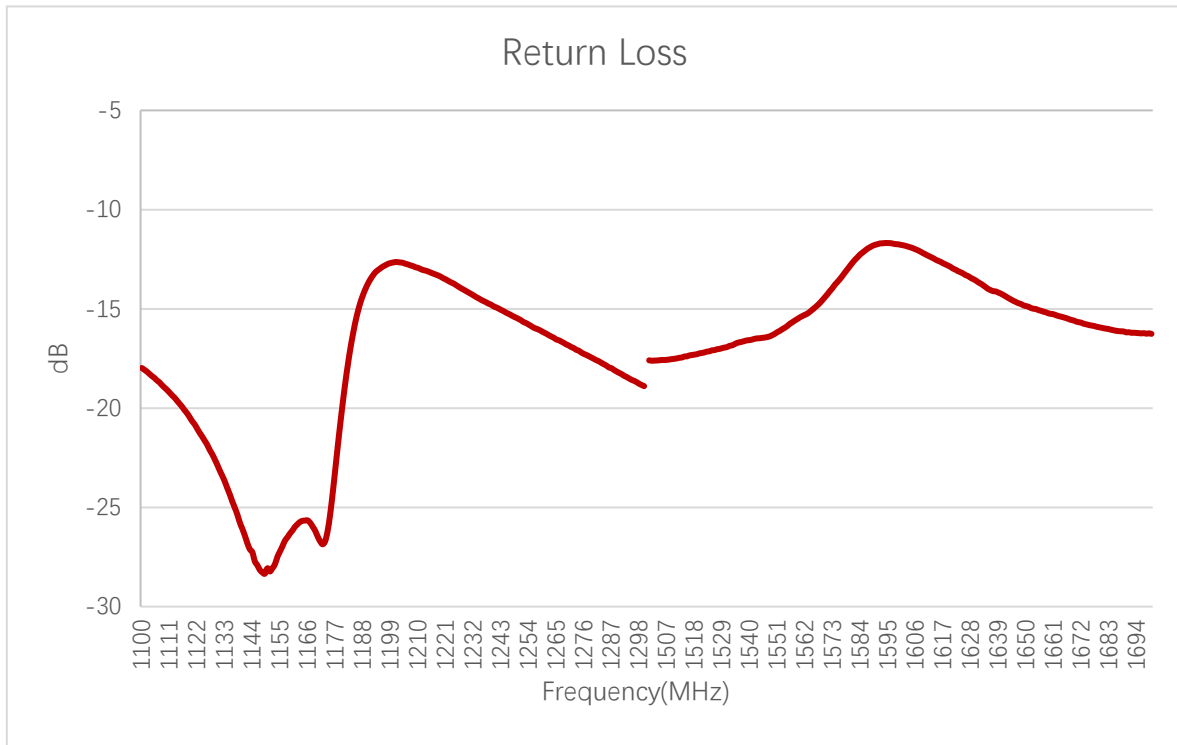

Return Loss (dB)

Frequency (MHz)	1176	1207	1227	1248	1268	1561	1575	1602
Return Loss (dB)	-24.2	-	-	-	-	-15.3	-13.6	-11.8

3.1.3. GNSS LNA Gain

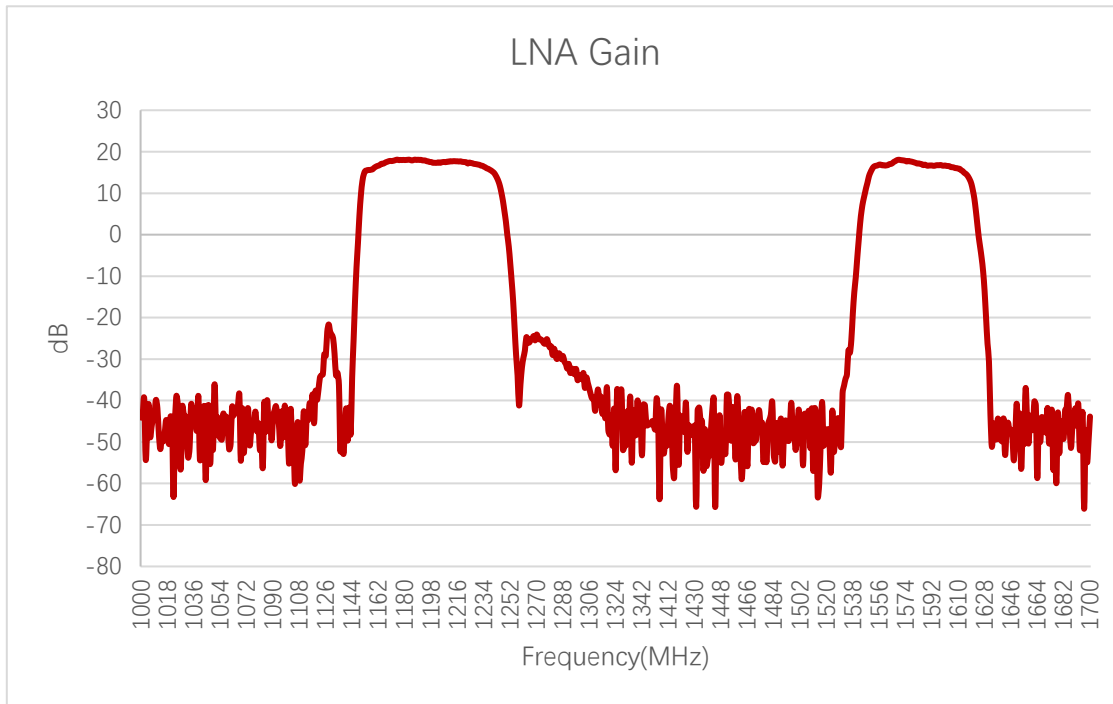

LNA Gain (dB)

Frequency (MHz)	1176	1207	1227	1248	1268	1561	1575	1602
LNA Gain (dB)	17.9	-	-	-	-	16.7	17.6	16.5

3.1.4. Noise Figure

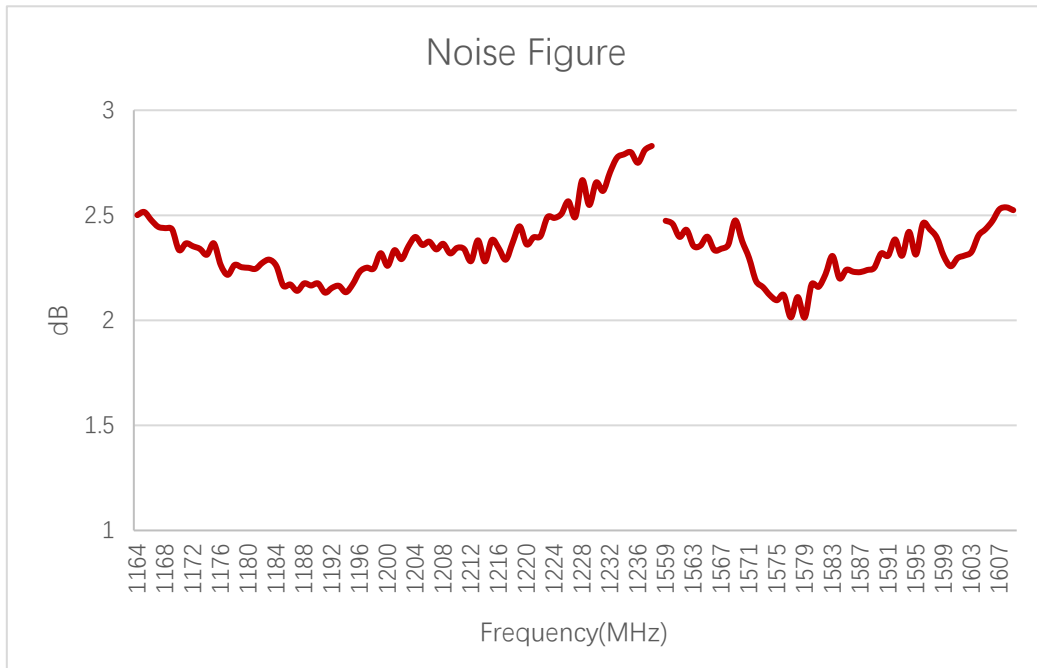

Noise Figure (dB)

Frequency (MHz)	1176	1207	1227	1248	1268	1561	1575	1602
Noise Figure (dB)	2.26	-	-	-	-	2.39	2.09	2.3

3.2. Radiation Performance Test

3.2.1. Efficiency

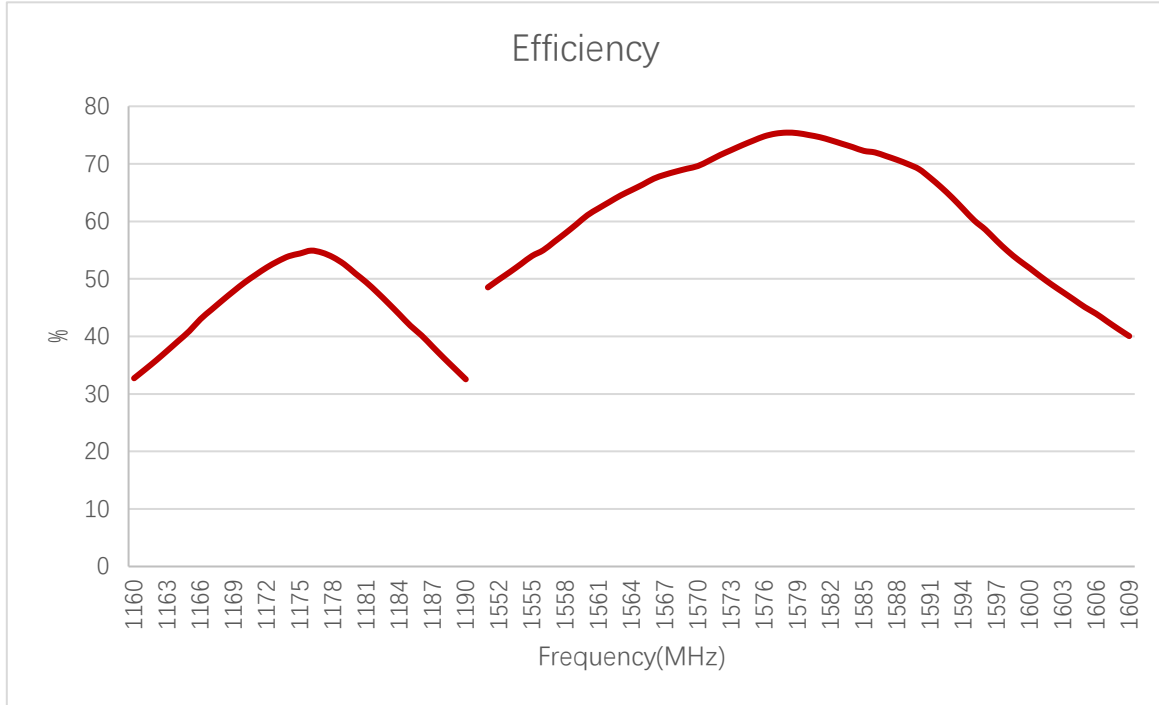

Efficiency (%)

Frequency (MHz)	1176	1207	1227	1248	1268	1561	1575	1602
Efficiency (%)	54.9	-	-	-	-	62	74	48.9

3.2.2. Peak Gain

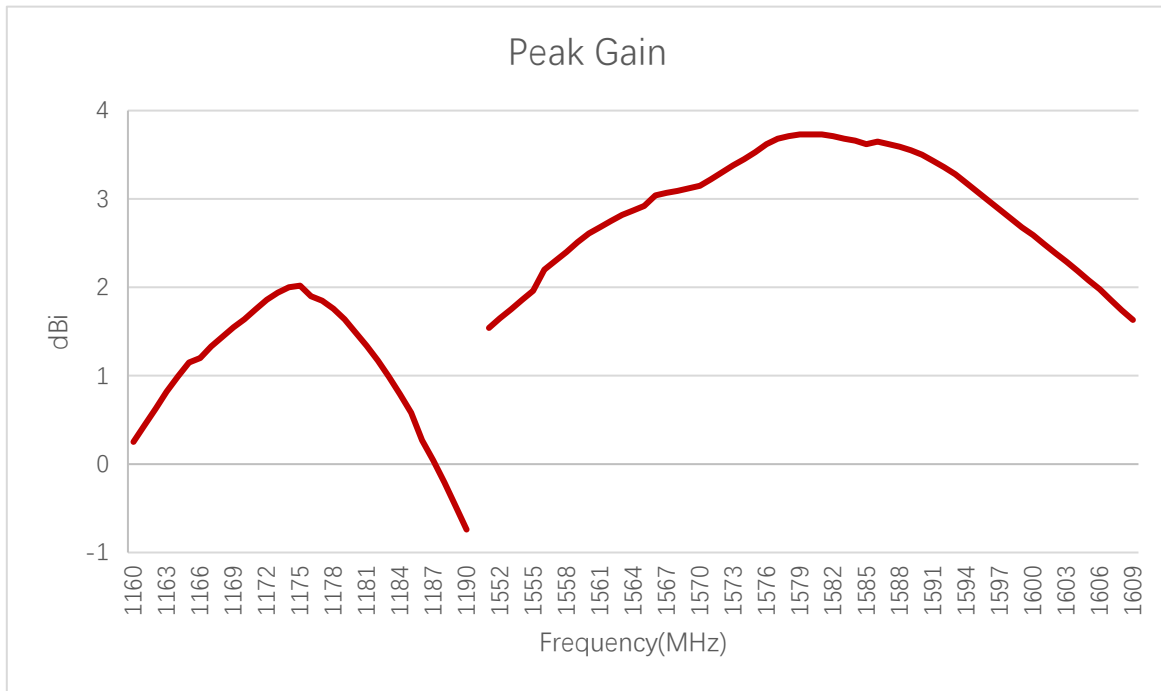

Peak Gain (dBi)

Frequency (MHz)	1176	1207	1227	1248	1268	1561	1575	1602
Peak Gain (dBi)	1.9	-	-	-	-	2.68	3.53	2.39

3.2.3. Axial Ratio

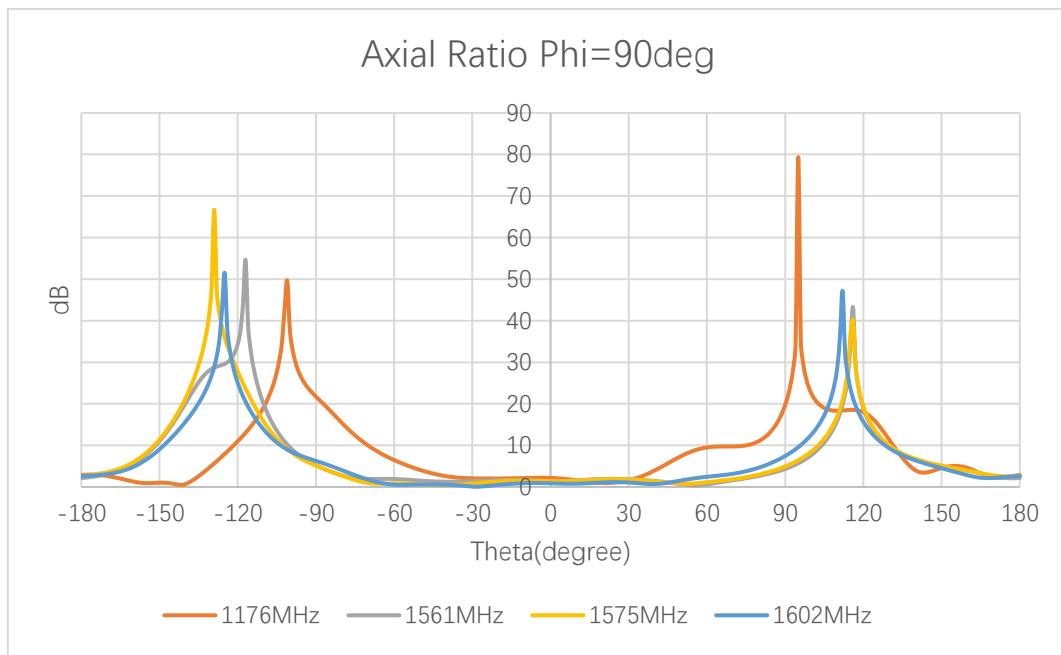
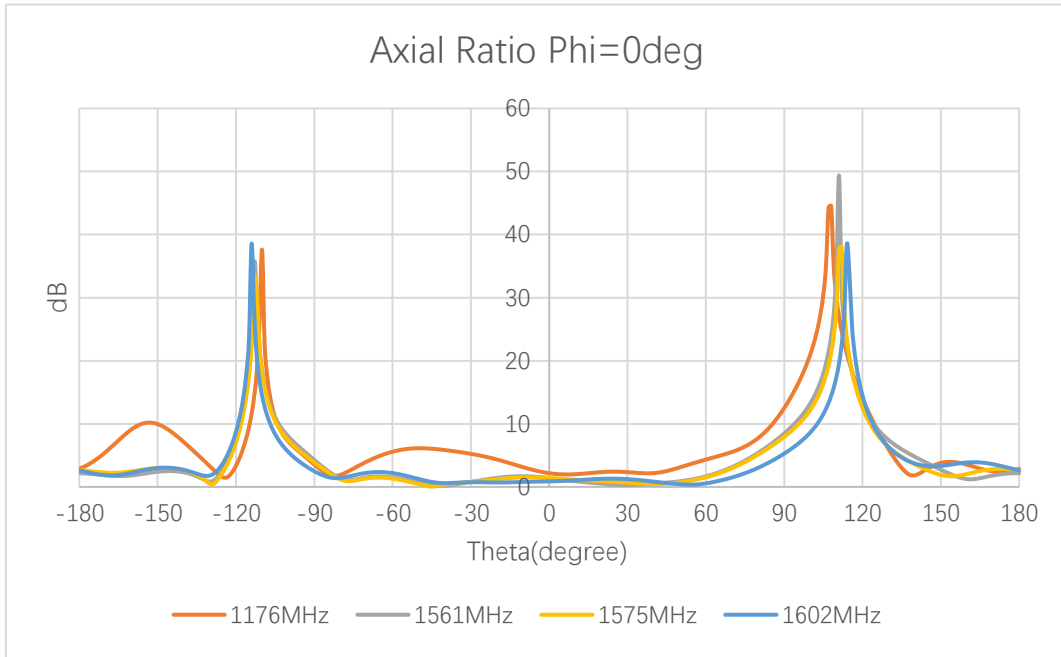

Axial Ratio (dB)

Frequency (MHz)		1176	1207	1227	1248	1268	1561	1575	1602
Axial Ratio (dB)	Phi = 0 (deg) Theta = 0 (deg)	2.1	-	-	-	-	1.4	1.4	0.88
	Phi = 90 (deg) Theta = 0 (deg)	2.1	-	-	-	-	1.4	1.4	0.88

3.2.4. 2D RHCP and LHCP Gain

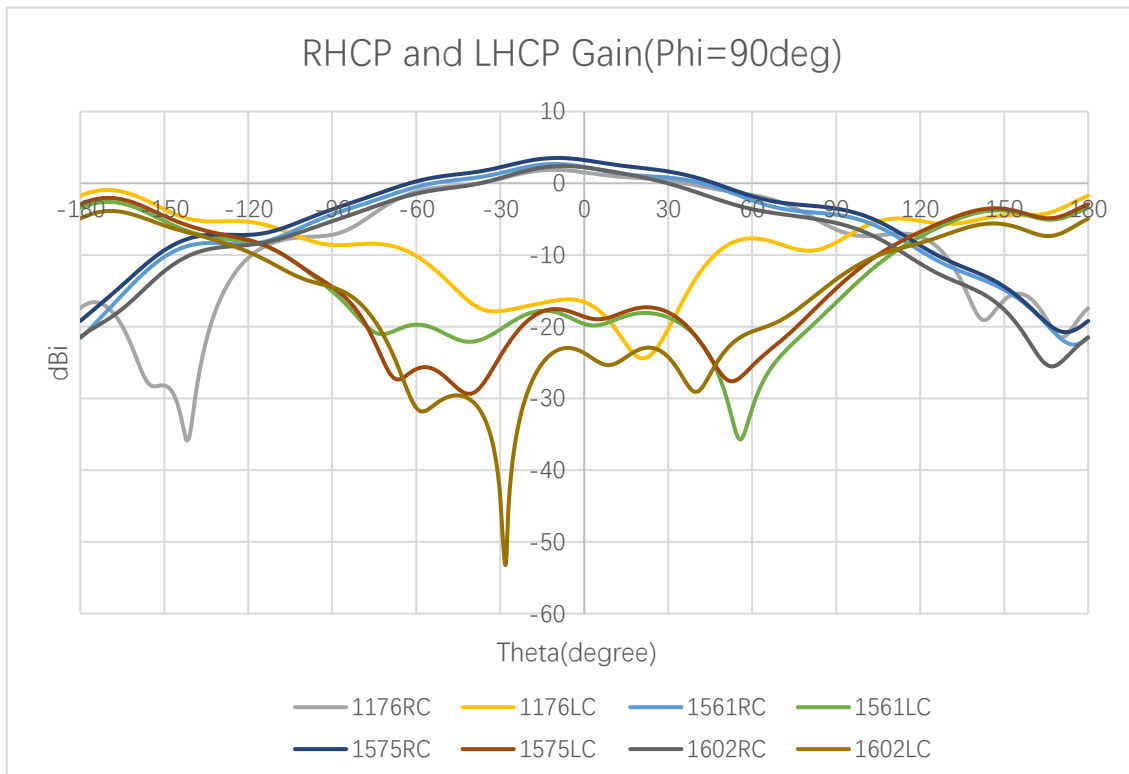
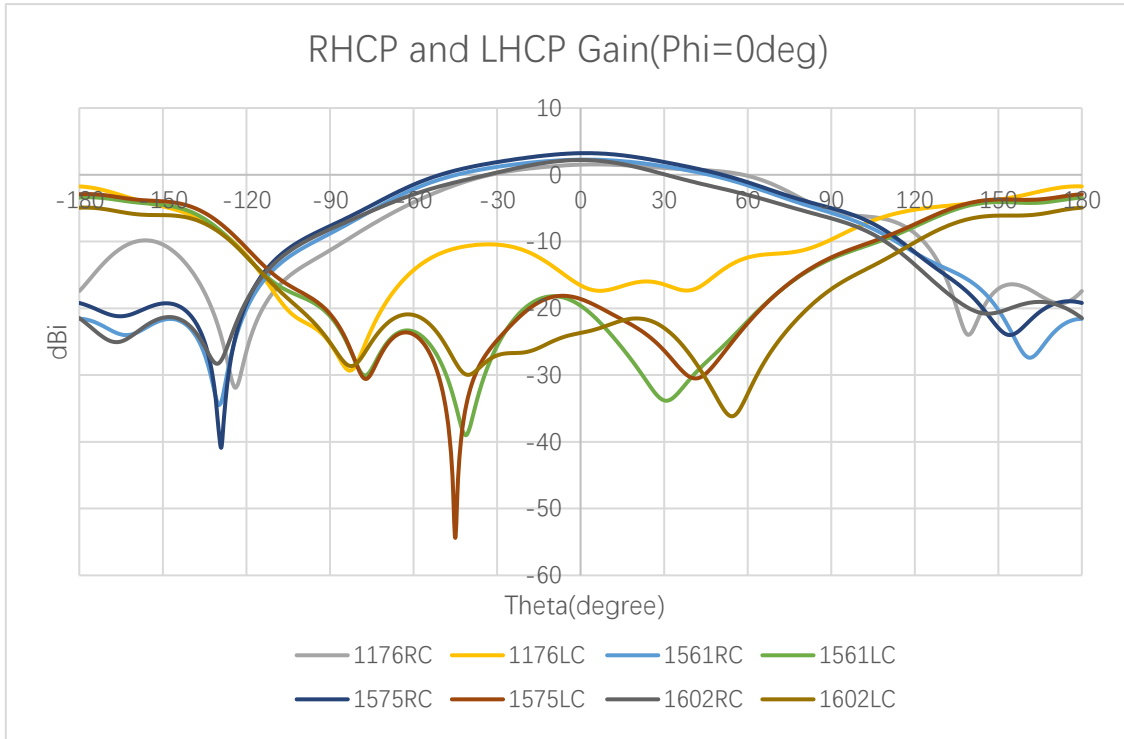

2D RHCP and LHCP Gain (dBi)

Frequency (MHz)		1176	1207	1227	1248	1268	1561	1575	1602
RC Gain (dBi)	Phi = 0 (deg) Theta = 0 (deg)	1.52	-	-	-	-	2.27	3.24	2.22
	Phi = 90 (deg) Theta = 0 (deg)	1.52	-	-	-	-	2.27	3.24	2.22
LC Gain (dBi)	Phi = 0 (deg) Theta = 0 (deg)	-16.56	-	-	-	-	-19.6	-18.6	-23.6
	Phi = 90 (deg) Theta = 0 (deg)	-16.56	-	-	-	-	-19.6	-18.6	-23.6

3.2.5. 3D & 2D Radiation Pattern

- Test Condition: Free Space
- Test Chamber: SH-SY-16M

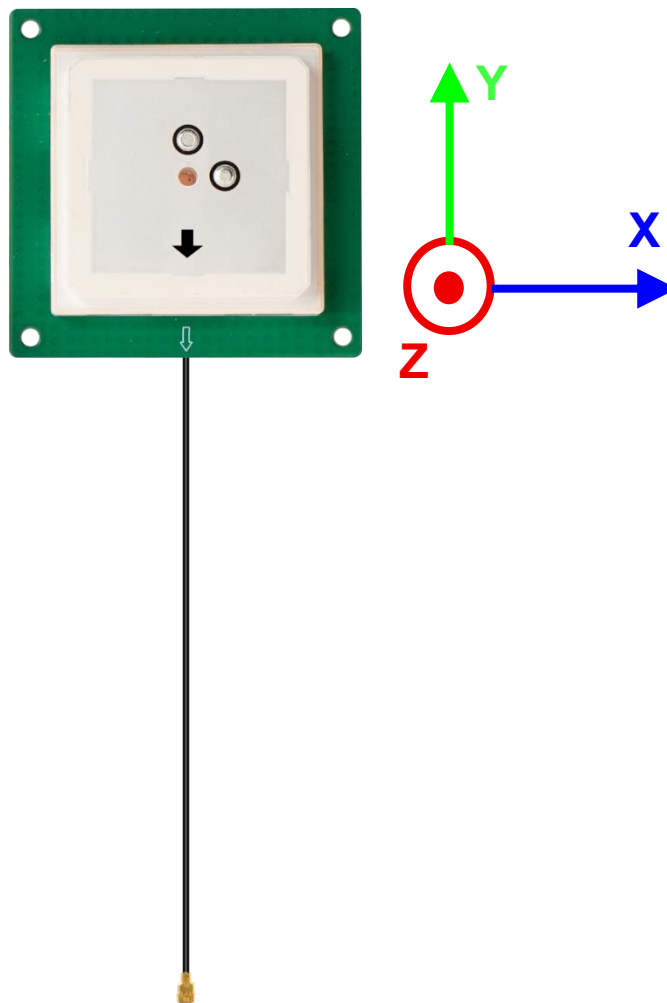

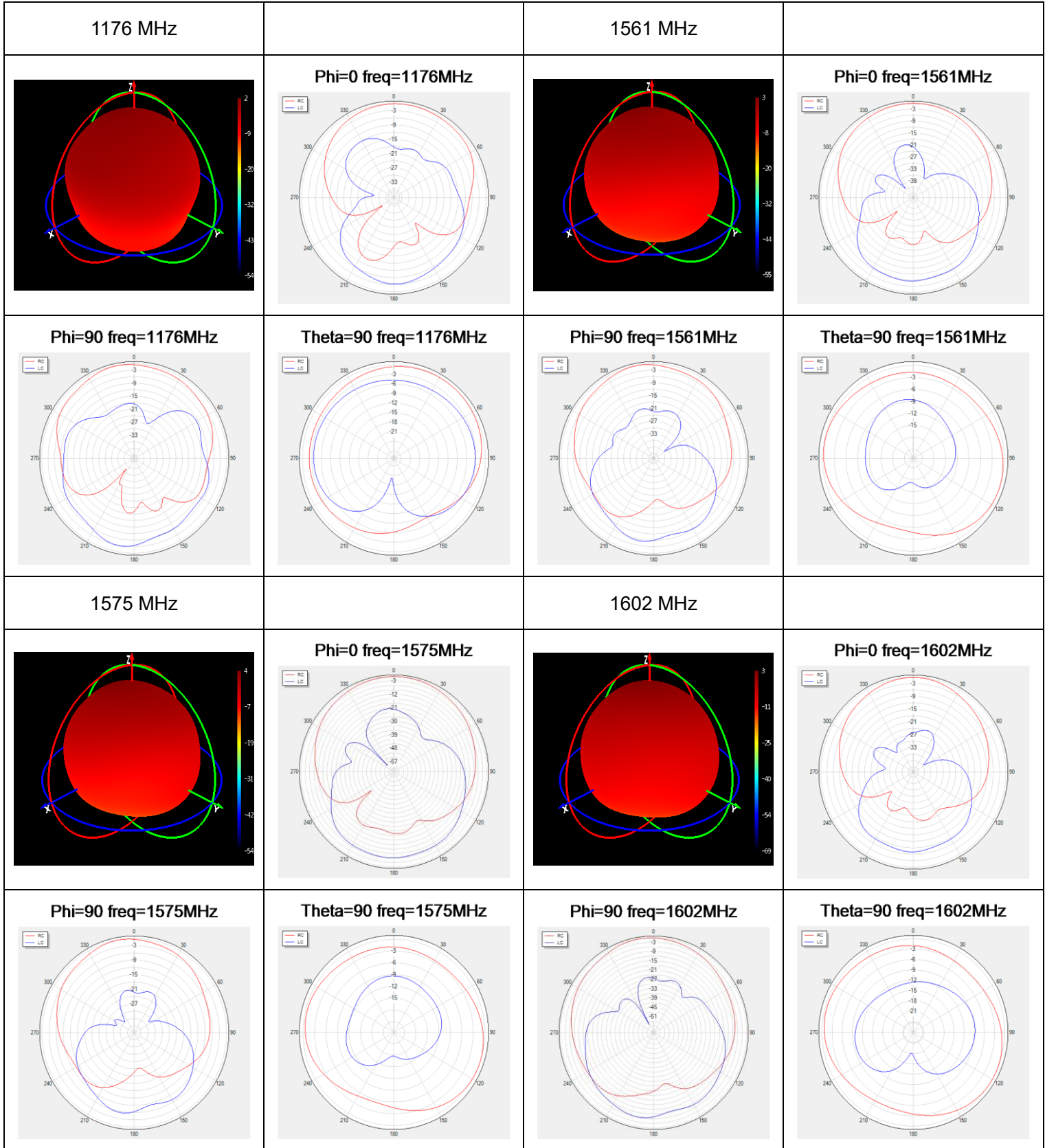

4 Packaging

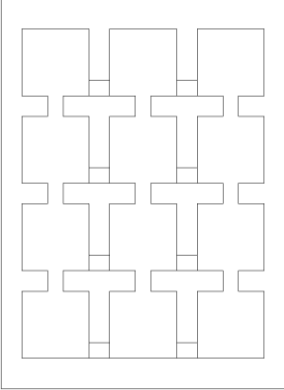
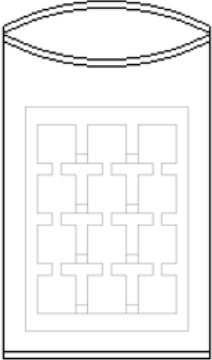
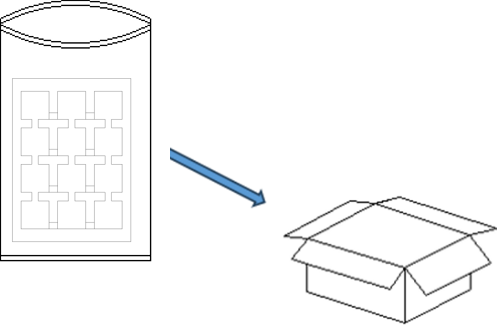
Step	Packaging Picture/2D Picture	Description
1		(12 Antennas / Pearl Cotton Tray)
2		The pearl cotton tray is vacuumed in a vacuum bag.
3		(4 Pearl Cotton Trays / Carton Box) (48 Antennas / Carton Box) <u>Carton Size:</u> <u>L × W × H = 405 × 293 × 185 mm</u>

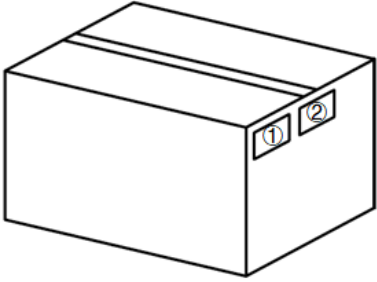
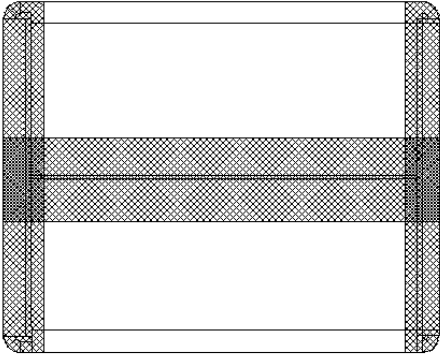
4	 A 3D perspective drawing of a rectangular carton. On the front face, there are two small rectangular labels. The left label is marked with a circled '1' and the right label is marked with a circled '2'.	<p>Position for Attaching Labels</p> <ul style="list-style-type: none">① Carton Label② Quality Label
5	 A 2D perspective drawing of a rectangular carton. The top and bottom edges are shaded with a cross-hatch pattern, indicating they are sealed. The front and back edges are also shaded with a cross-hatch pattern, indicating they are sealed.	<p>Sealing Cartons H-shaped sealing cartons</p>

Contact Us

At Quectel, our aim is to provide timely and comprehensive services to our customers. If you require any assistance, please contact our headquarters:

Quectel Wireless Solutions Co., Ltd.

Building 5, Shanghai Business Park Phase III (Area B), No.1016 Tianlin Road, Minhang District, Shanghai 200233, China

Tel: +86 21 5108 6236

Email: info@quectel.com

Or our local offices. For more information, please visit:

<http://www.quectel.com/support/sales.htm>.

For technical support, or to report documentation errors, please visit:

<http://www.quectel.com/support/technical.htm>.

Or email us at: support@quectel.com.

Legal Notices

We offer information as a service to you. The provided information is based on your requirements and we make every effort to ensure its quality. You agree that you are responsible for using independent analysis and evaluation in designing intended products, and we provide reference designs for illustrative purposes only. Before using any hardware, software or service guided by this document, please read this notice carefully. Even though we employ commercially reasonable efforts to provide the best possible experience, you hereby acknowledge and agree that this document and related services hereunder are provided to you on an “as available” basis. We may revise or restate this document from time to time at our sole discretion without any prior notice to you.

Use and Disclosure Restrictions

License Agreements

Documents and information provided by us shall be kept confidential, unless specific permission is granted. They shall not be accessed or used for any purpose except as expressly provided herein.

Copyright

Our and third-party products hereunder may contain copyrighted material. Such copyrighted material shall not be copied, reproduced, distributed, merged, published, translated, or modified without prior written consent. We and the third party have exclusive rights over copyrighted material. No license shall be granted or conveyed under any patents, copyrights, trademarks, or service mark rights. To avoid ambiguities, purchasing in any form cannot be deemed as granting a license other than the normal non-exclusive, royalty-free license to use the material. We reserve the right to take legal action for noncompliance with abovementioned requirements, unauthorized use, or other illegal or malicious use of the material.

Trademarks

Except as otherwise set forth herein, nothing in this document shall be construed as conferring any rights to use any trademark, trade name or name, abbreviation, or counterfeit product thereof owned by Quectel or any third party in advertising, publicity, or other aspects.

Third-Party Rights

This document may refer to hardware, software and/or documentation owned by one or more third parties (“third-party materials”). Use of such third-party materials shall be governed by all restrictions and obligations applicable thereto.

We make no warranty or representation, either express or implied, regarding the third-party materials, including but not limited to any implied or statutory, warranties of merchantability or fitness for a particular purpose, quiet enjoyment, system integration, information accuracy, and non-infringement of any third-party intellectual property rights with regard to the licensed technology or use thereof. Nothing herein constitutes a representation or warranty by us to either develop, enhance, modify, distribute, market, sell, offer for sale, or otherwise maintain production of any our products or any other hardware, software, device, tool, information, or product. We moreover disclaim any and all warranties arising from the course of dealing or usage of trade.

Privacy Policy

To implement module functionality, certain device data are uploaded to Quectel's or third-party's servers, including carriers, chipset suppliers or customer-designated servers. Quectel, strictly abiding by the relevant laws and regulations, shall retain, use, disclose or otherwise process relevant data for the purpose of performing the service only or as permitted by applicable laws. Before data interaction with third parties, please be informed of their privacy and data security policy.

Disclaimer

- a) We acknowledge no liability for any injury or damage arising from the reliance upon the information.
- b) We shall bear no liability resulting from any inaccuracies or omissions, or from the use of the information contained herein.
- c) While we have made every effort to ensure that the functions and features under development are free from errors, it is possible that they could contain errors, inaccuracies, and omissions. Unless otherwise provided by valid agreement, we make no warranties of any kind, either implied or express, and exclude all liability for any loss or damage suffered in connection with the use of features and functions under development, to the maximum extent permitted by law, regardless of whether such loss or damage may have been foreseeable.
- d) We are not responsible for the accessibility, safety, accuracy, availability, legality, or completeness of information, advertising, commercial offers, products, services, and materials on third-party websites and third-party resources.

Copyright © Quectel Wireless Solutions Co., Ltd. 2025. All rights reserved.

Revision History

Version	Date	Author	Note
-	2024-04-22	Junsen Li/ Mike Guo/ David Liu/ Rainey Liao	Creation of the document
1.0	2024-04-22	Junsen Li/ Mike Guo/ David Liu/ Rainey Liao	First official release
1.1	2024-11-19	Mike Guo	Deleted adhesive mounting type of antenna (Chapter 1.2).
1.2	2025-07-21	Aria Chu	1. Updated the antenna image (Cover page). 2. Updated the overview.
1.3	2025-10-27	Junsen Li	Added the LNA gains according to different supply voltages (Chapter 1.1).

QUECTEL

www.quectel.com