

Antenna Datasheet

Product OC: YFBC001WWA

Version: 2.0

Date: 2025-07-07

Status: Released

Product Name: Wi-Fi SMT Mount Ceramic Chip Loop Embedded Antenna

Key Features:

Frequency band: 2400–2500 MHz, 5150–5850 MHz, 5925–7125 MHz

V2X: 5850–5925 MHz

Peak efficiency: 67.18 %

Dimensions: 1.6 × 0.8 × 0.4 mm

RoHS and REACH Compliant

Overview

Quectel YFBC001WWA is a compact form factor SMT mount ceramic chip antenna for Wi-Fi applications. Due to the dimensions of $1.6 \times 0.8 \times 0.4$ mm, it is designed for very small space requirements for Wi-Fi, WLAN, BT, Zigbee and 802.11 terminals. YFBC001WWA is a ground-dependent loop antenna, uses main PCB as its ground plane. It is delivered on tape and reel.

YFBC001WWA is a ceramic chip antenna, which can be mounted on terminals with super compact space requirement. Despite of this small factor, it has up to 67.18% efficiency in working bands. This antenna is developed on a 60×50 mm evaluation board. If the devices have different ground sizes, matching circuit can be used to tune the resonant frequency correctly. We also offer gerber file, 2D & 3D documents for PCB layout.

YFBC001WWA allows high efficiency, stable signal transmission and reception for Wi-Fi working bands in 2400–2500 MHz & 5150–5850 MHz & 5925–7125 MHz & 5850–5925 MHz. This product is RoHS & REACH compliant.

Typical applications include:

- Hand-held devices
- Bluetooth earphone systems
- Hand-held devices when Bluetooth/Wi-Fi functions are needed, e.g., Smart phone.
- IEEE802.11 b/g/n
- ZigBee
- Wireless PCMCIA cards or USB dongle

Quectel provides comprehensive antenna design support such as simulation, testing and manufacturing for custom antenna solutions to meet your specific application needs. We have regional R & D centers to offer quick response to meet your requirements. Please contact our sales & FAEs if you have any requests.

Contents

| | |
|--|-----------|
| Overview | 1 |
| Contents | 2 |
| 1 Specification | 3 |
| 1.1. Electrical..... | 3 |
| 1.1.1. Wi-Fi..... | 3 |
| 1.1.2. V2X | 4 |
| 1.2. Mechanical & Environmental | 4 |
| 2 Drawing | 5 |
| 2.1. Antenna..... | 5 |
| 2.2. EVB | 6 |
| 3 Detailed Performance | 7 |
| 3.1. S-Parameter Test | 7 |
| 3.1.1. VSWR | 7 |
| 3.1.2. Return Loss..... | 8 |
| 3.2. Radiation Performance Test..... | 9 |
| 3.2.1. Efficiency..... | 9 |
| 3.2.2. Average Gain | 10 |
| 3.2.3. Peak Gain | 11 |
| 3.2.4. 3D & 2D Radiation Pattern | 12 |
| 4 Schematic Symbol and Pin Definition | 15 |
| 5 Transmission Line | 16 |
| 6 Recommended PCB Layout | 17 |
| 7 Matching Circuit | 18 |
| 8 Soldering Temperature | 19 |
| 9 Reflow Profile | 20 |
| 10 Packaging | 21 |
| Contact Us | 23 |
| Legal Notices | 24 |
| Revision History | 26 |

1 Specification

Test Condition: On 50 mm × 60 mm EVB

1.1. Electrical

| Electrical | | |
|-------------------|------------------|---|
| Frequency Range | Wi-Fi | 2400–2500 MHz, 5150–5850 MHz, 5925–7125 MHz |
| | V2X | 5850–5925 MHz |
| Impedance | 50 Ω | |
| Polarization | Linear | |
| Radiation Pattern | Omni-directional | |

1.1.1. Wi-Fi

| Specification | Band | Wi-Fi 2G | Wi-Fi 5G | Wi-Fi 6G |
|-----------------------|-----------|-----------|-----------|-----------|
| | | 2400–2500 | 5150–5850 | 5925–7125 |
| Max. VSWR | | 2.8 | 2.3 | 3.8 |
| Max. Return Loss (dB) | | -6.6 | -8.1 | -4.7 |
| AVG Eff. (%) | | 49.6 | 58.2 | 48.2 |
| AVG Gain (dB) | | -3.1 | -2.4 | -3.3 |
| Max. Peak Gain (dBi) | | -0.3 | 2.3 | 1.5 |
| VSWR | ≤ 3.8 | | | |
| Return Loss | ≤ -4.7 dB | | | |
| Peak Gain | ≤ 2.3 dBi | | | |

1.1.2. V2X

| Specification | Band | Band | V2X |
|----------------------|------|-------------|-----------|
| | | Freq. (MHz) | 5850–5925 |
| Max. VSWR | | | 2.3 |
| Max. Return Loss(dB) | | | -8.2 |
| AVG Eff. (%) | | | 52.0 |
| AVG AVG Gain (dB) | | | -2.8 |
| Max. Peak Gain (dBi) | | | 0.9 |
| VSWR | | ≤ 2.3 | |
| Return Loss | | ≤ -8.2 dB | |
| Peak Gain | | ≤ 0.9 dBi | |

1.2. Mechanical & Environmental

| Mechanical | |
|--------------------------|-------------------------|
| Antenna Size | 1.6 × 0.8 × 0.4 mm |
| Antenna Material & Color | Ceramic & Natural Color |
| Antenna Weight | Typ. 0.00209 g |
| Mounting Type | SMD |
| Recommended EVB Size | 60 × 50 × 1.0 mm |
| Environmental | |
| Operation Temperature | -40 °C to +95 °C |
| Storage Temperature | -40 °C to +85 °C |
| RoHS and REACH Compliant | Yes |

2 Drawing

2.1. Antenna

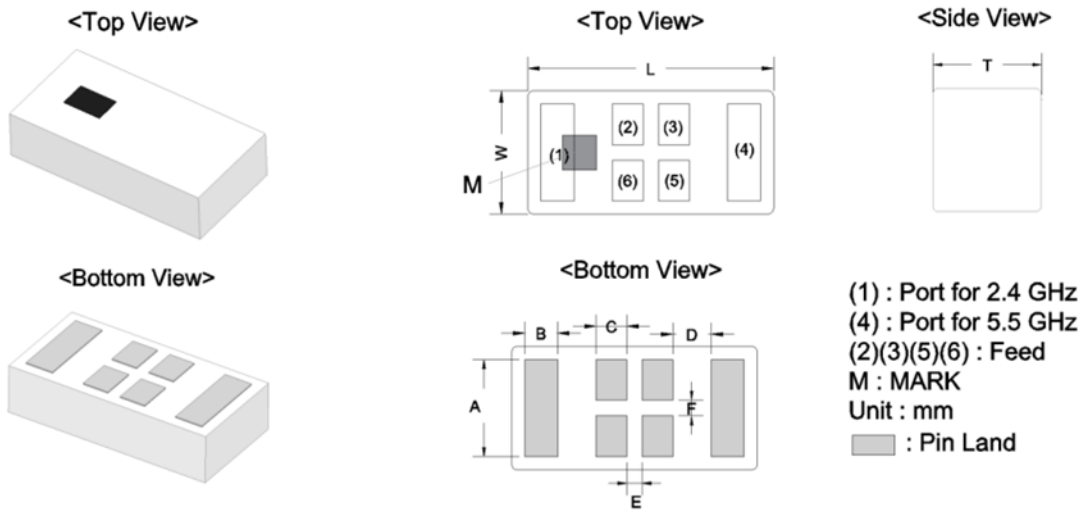

| MARK | L | W | T | A | B | C | D | E | F |
|------------|------------|------------|------------|------------|------------|------------|------------|------------|------------|
| Dimensions | 1.60 | 0.80 | 0.40 | 0.63 | 0.215 | 0.20 | 0.25 | 0.10 | 0.10 |
| (mm) | ± 0.10 | ± 0.10 | ± 0.10 | ± 0.10 | ± 0.10 | ± 0.10 | ± 0.10 | ± 0.10 | ± 0.10 |

2.2. EVB

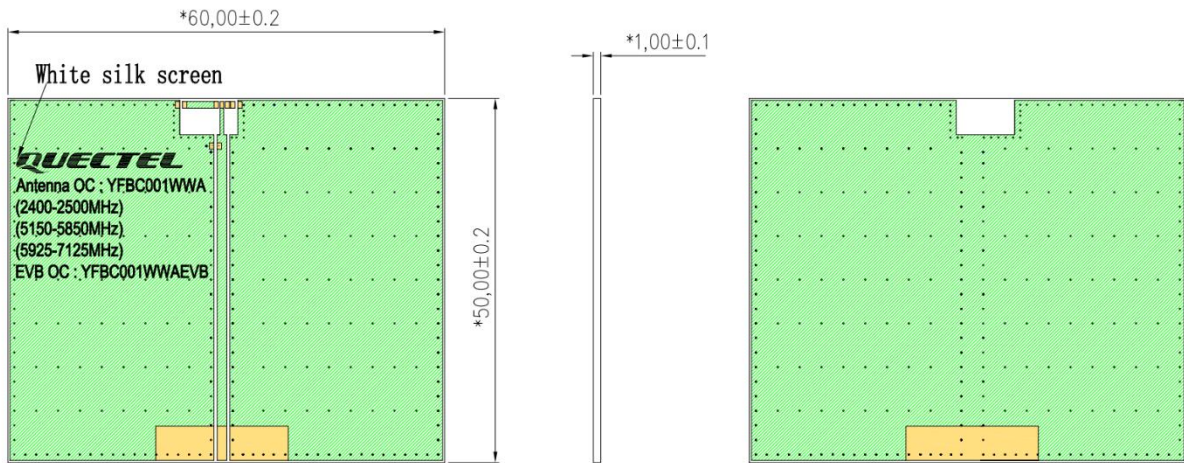

3 Detailed Performance

3.1. S-Parameter Test

3.1.1. VSWR

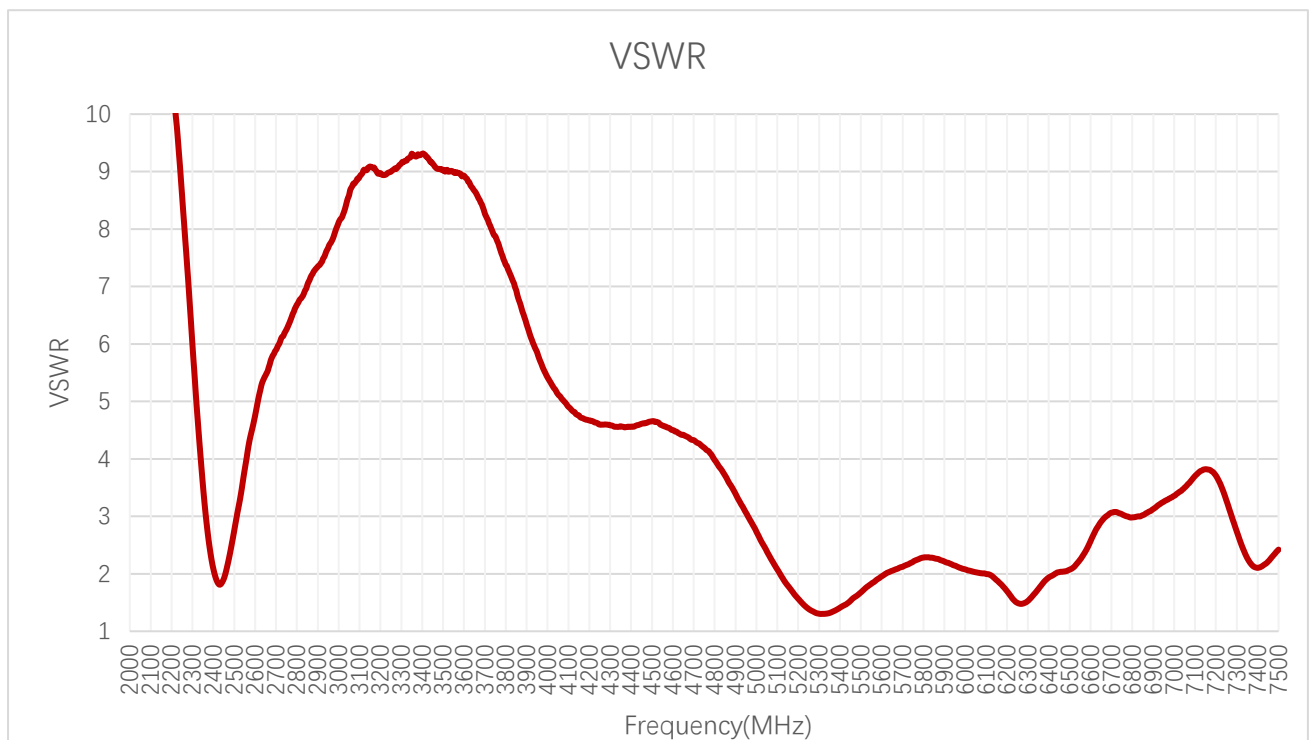

VSWR

| Frequency (MHz) | 2400 | 2450 | 2500 | 5150 | 5500 | 5850 | 5925 | 6725 | 7125 |
|-----------------|------|------|------|------|------|------|------|------|------|
| VSWR | 2.1 | 1.9 | 2.8 | 1.8 | 1.7 | 2.3 | 2.2 | 3.1 | 3.8 |

VSWR – V2X

| Frequency (MHz) | 5860 | 5880 | 5900 |
|-----------------|------|------|------|
| VSWR | 2.3 | 2.2 | 2.2 |

3.1.2. Return Loss

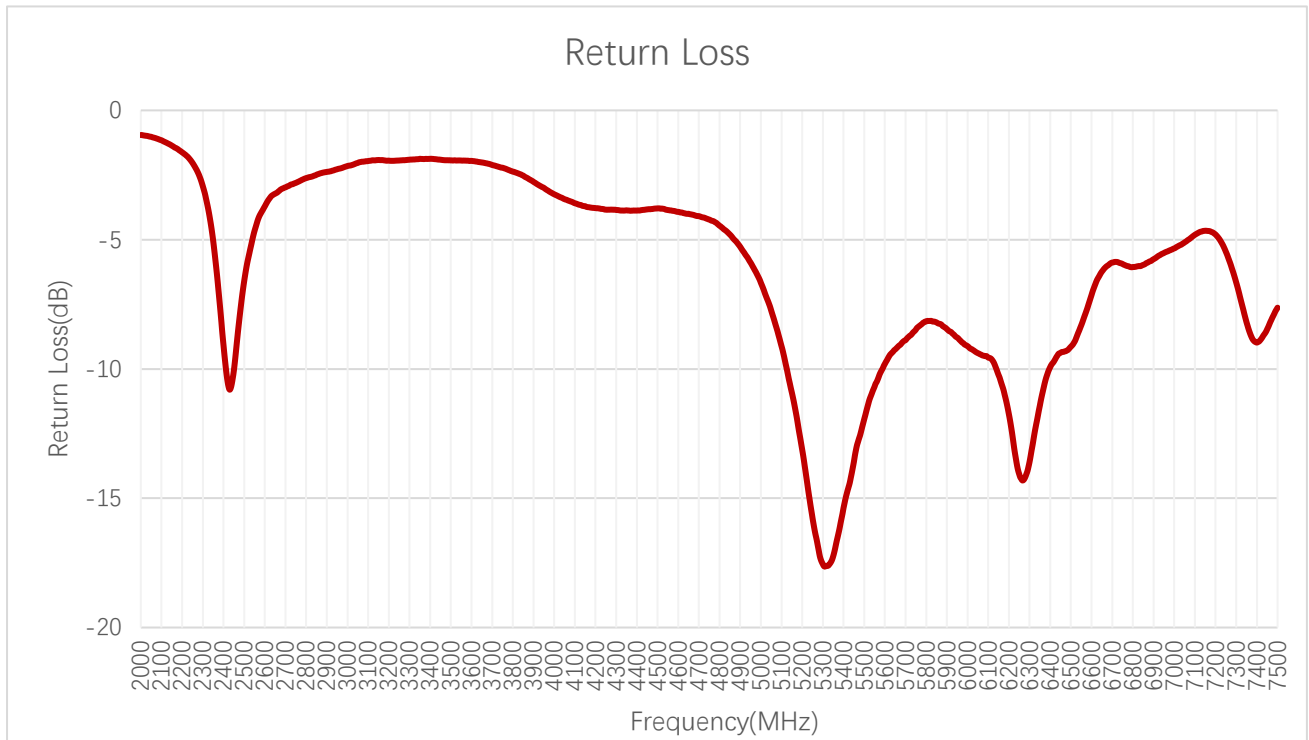

Return Loss (dB)

| Frequency (MHz) | 2400 | 2450 | 2500 | 5150 | 5500 | 5850 | 5925 | 6725 | 7125 |
|------------------|------|-------|------|-------|-------|------|------|------|------|
| Return Loss (dB) | -9.1 | -10.1 | -6.6 | -10.9 | -11.9 | -8.2 | -8.6 | -5.9 | -4.7 |

Return Loss (dB) – V2X

| Frequency (MHz) | 5860 | 5880 | 5900 |
|------------------|------|------|------|
| Return Loss (dB) | -8.2 | -8.4 | -8.5 |

3.2. Radiation Performance Test

3.2.1. Efficiency

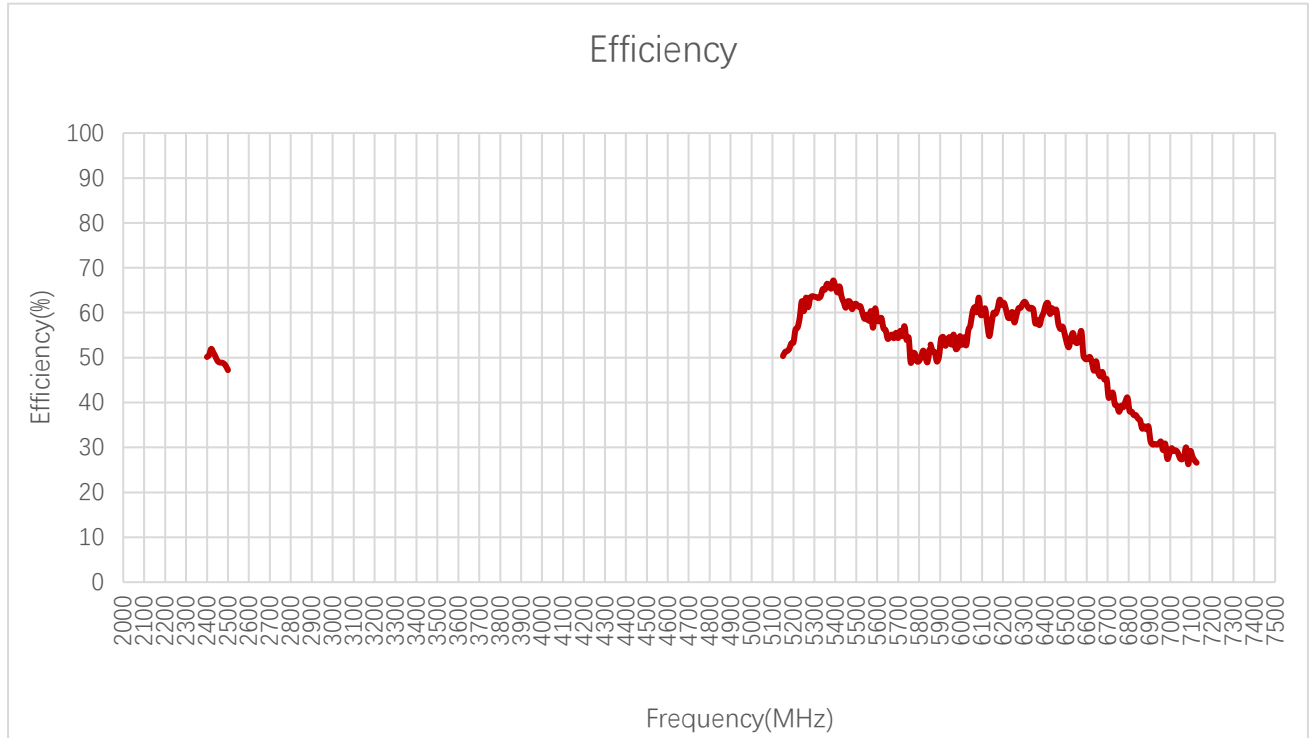

Efficiency (%)

| Frequency (MHz) | 2400 | 2450 | 2500 | 5150 | 5500 | 5850 | 5925 | 6725 | 7125 |
|-----------------|------|------|------|------|------|------|------|------|------|
| Efficiency (%) | 50.2 | 49.3 | 47.2 | 50.3 | 62.0 | 51.8 | 52.7 | 42.2 | 26.6 |

Efficiency (%) – V2X

| Frequency (MHz) | 5860 | 5880 | 5900 |
|-----------------|------|------|------|
| Efficiency (%) | 52.9 | 51.2 | 50.3 |

3.2.2. Average Gain

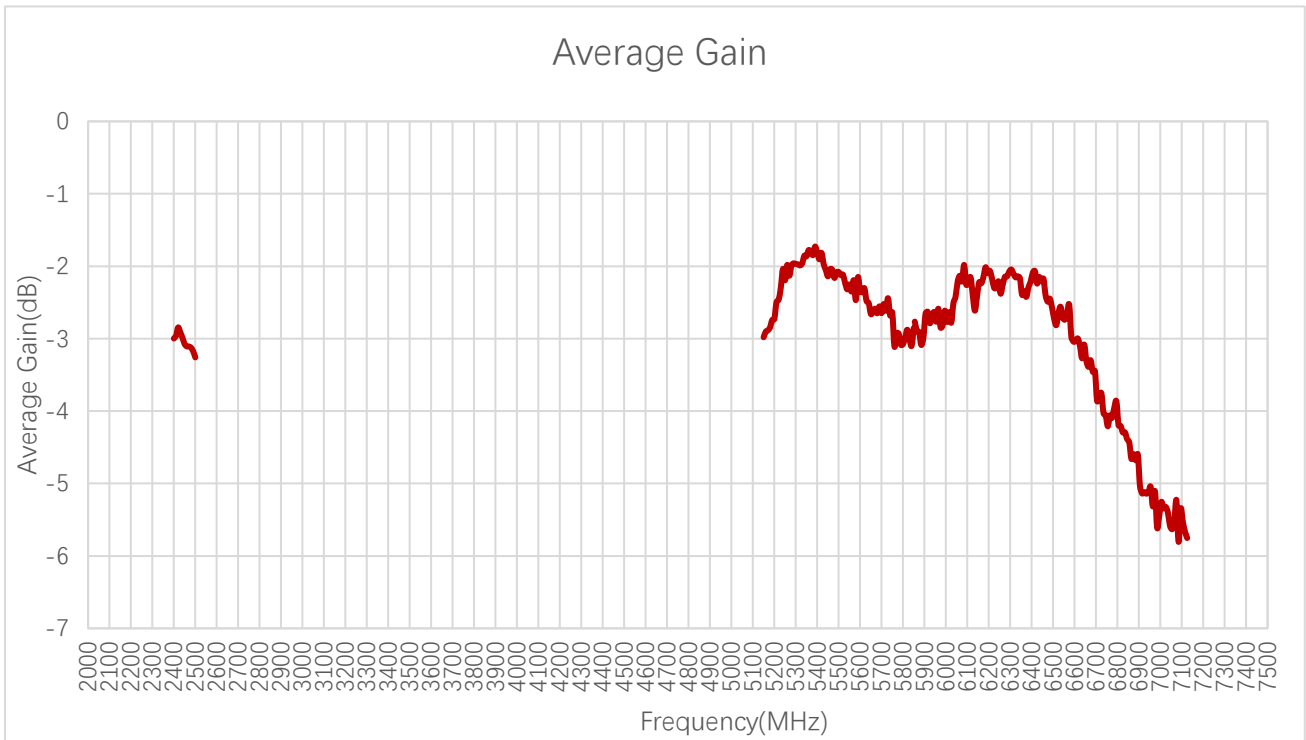

Average Gain (dB)

| Frequency (MHz) | 2400 | 2450 | 2500 | 5150 | 5500 | 5850 | 5925 | 6725 | 7125 |
|-------------------|------|------|------|------|------|------|------|------|------|
| Average Gain (dB) | -3.0 | -3.1 | -3.3 | -3.0 | -2.1 | -2.9 | -2.8 | -3.8 | -5.8 |

Average Gain (dB) – V2X

| Frequency (MHz) | 5860 | 5880 | 5900 |
|-------------------|------|------|------|
| Average Gain (dB) | -2.8 | -2.9 | -3.0 |

3.2.3. Peak Gain

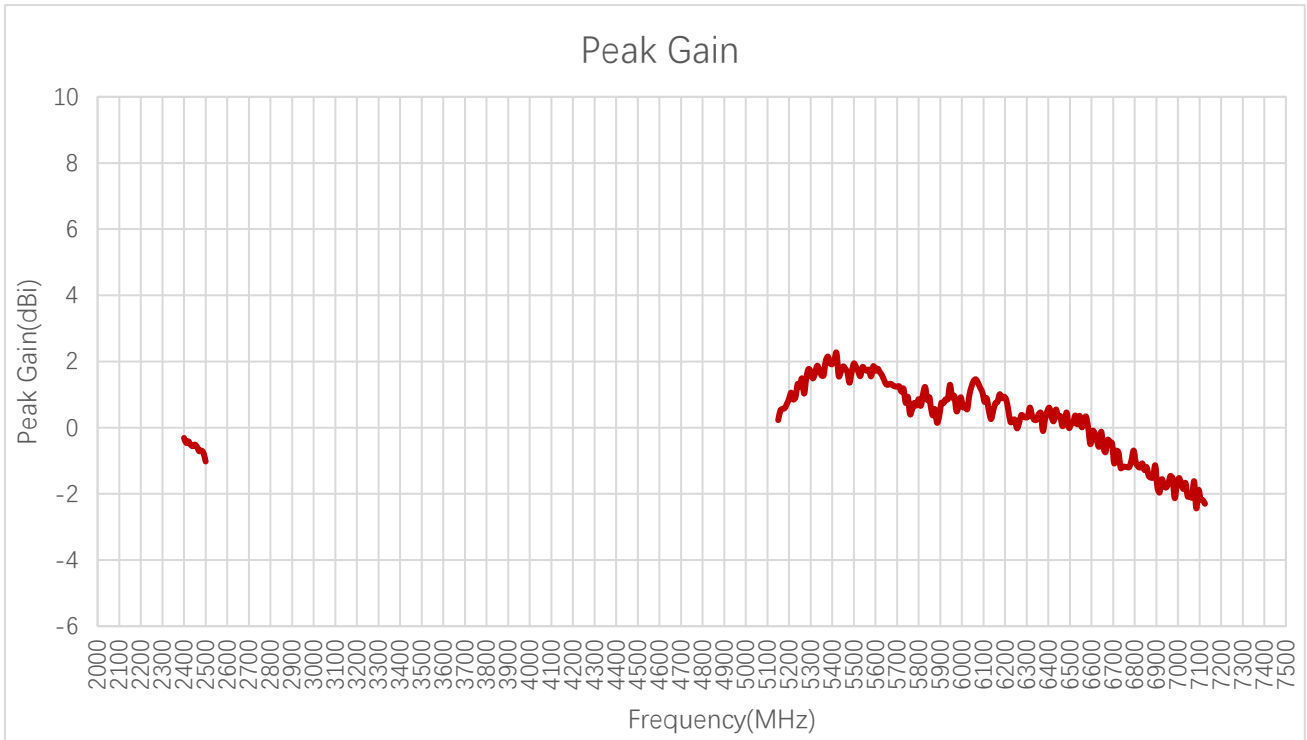

Peak Gain (dBi)

| Frequency (MHz) | 2400 | 2450 | 2500 | 5150 | 5500 | 5850 | 5925 | 6725 | 7125 |
|-----------------|------|------|------|------|------|------|------|------|------|
| Peak Gain (dBi) | -0.3 | -0.5 | -1.0 | 0.2 | 1.9 | 0.9 | 0.9 | -0.8 | -2.3 |

Peak Gain (dBi) – V2X

| Frequency (MHz) | 5860 | 5880 | 5900 |
|-----------------|------|------|------|
| Peak Gain (dBi) | 0.7 | 0.6 | 0.4 |

3.2.4. 3D & 2D Radiation Pattern

- Test Condition: On 50 mm × 60 mm EVB
- Test Chamber: GL-G-1

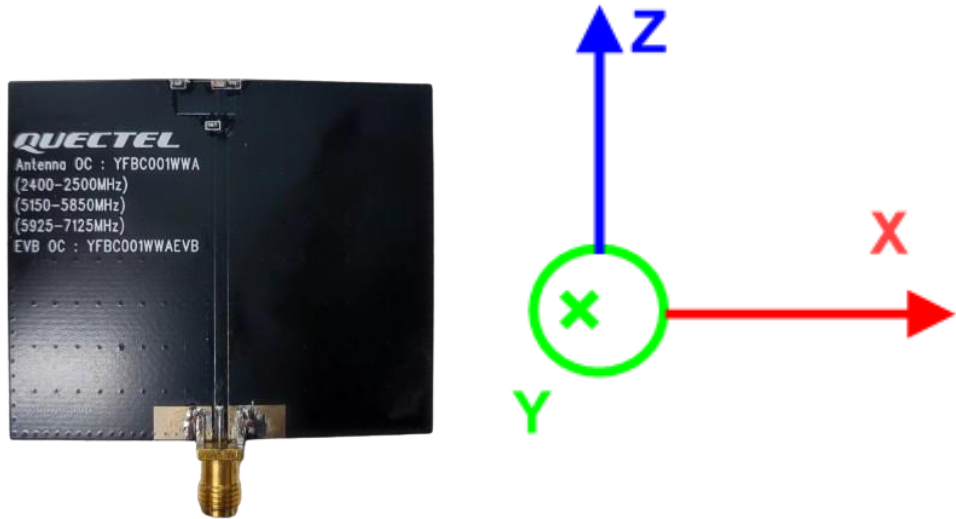

● Wi-Fi

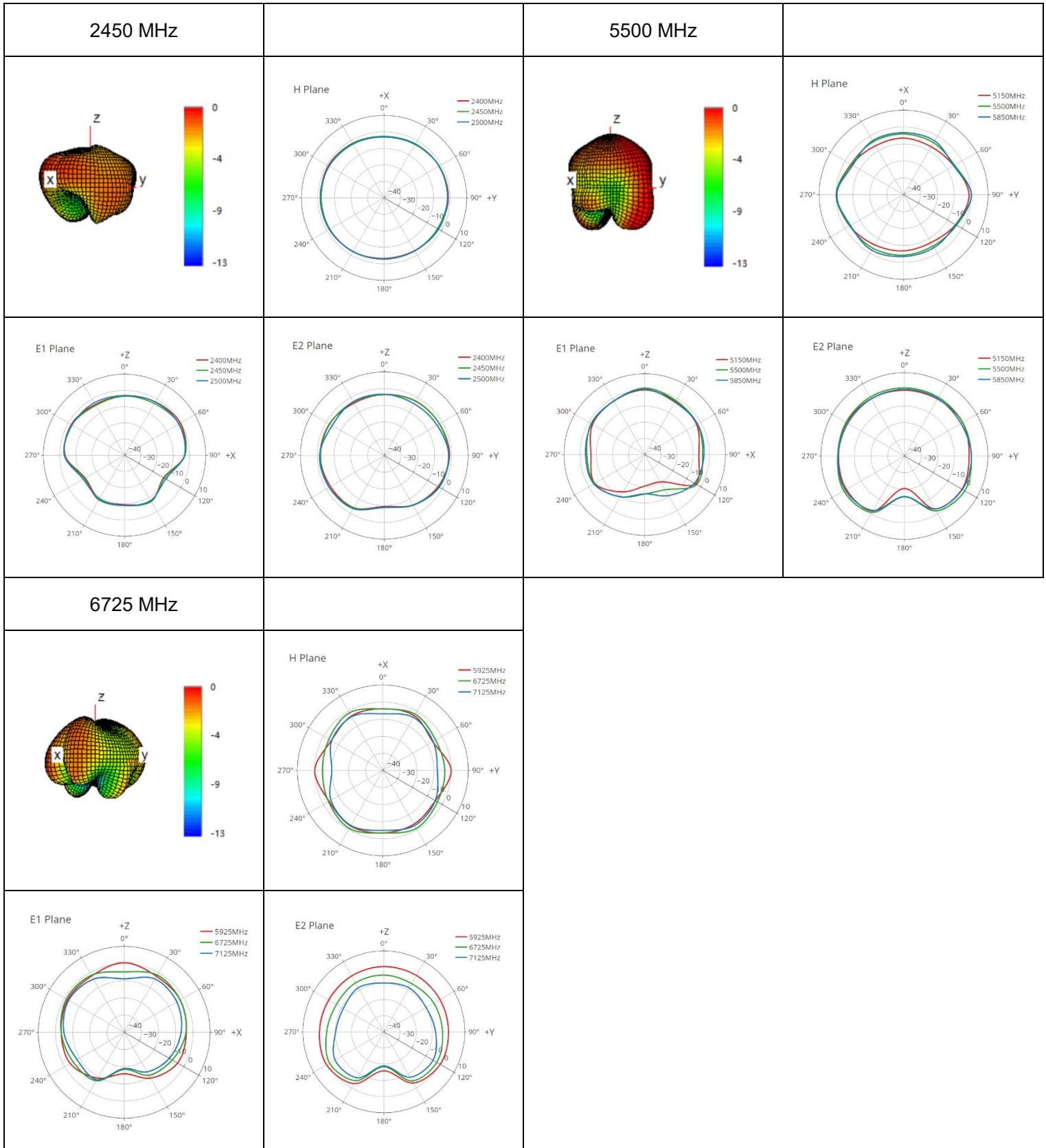

● V2X

5880 MHz

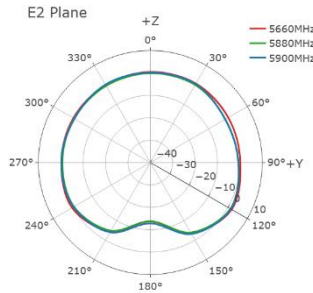
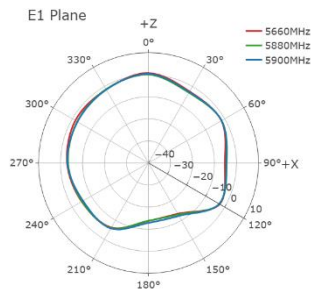
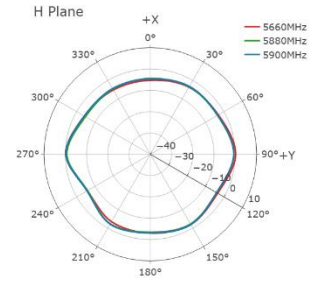
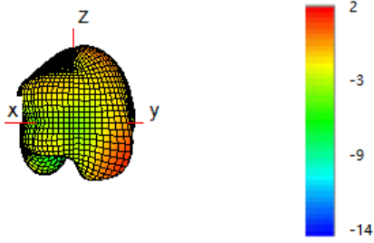

4 Schematic Symbol and Pin Definition

- The pin assignment for the antenna is as follows.
- The circuit symbol for the antenna is shown below. The antenna has 6 pins, six of which work. All other pins are for mechanical strength.

| Pin | Description |
|------------|----------------|
| 2, 3, 5, 6 | Feed |
| 1, 4 | Antenna Tuning |



Top

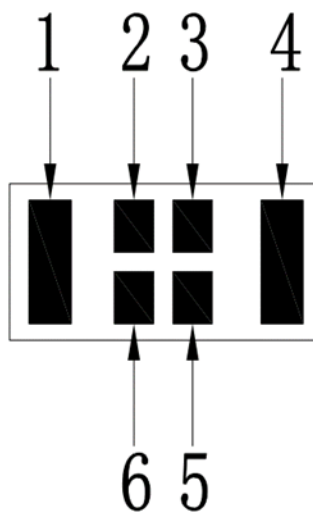

Bottom

5 Transmission Line

The characteristic impedance of all transmission lines shall be designed as 50 Ω .

- The length of the transmission lines should be kept as short as possible.
- Any other part of the RF system, such as transceiver, power amplifiers, etc., shall also be designed with an impedance of 50 Ω .

Once the material for the PCB has been chosen (PCB thickness and dielectric constant), a coplanar transmission line can easily be designed using any of the commercial software packages for transmission line design. For the chosen PCB thickness, copper thickness and substrate dielectric constant, the program will calculate the appropriate transmission line width and gaps on either side of the track so the characteristic impedance of the coplanar transmission is 50 Ω .

6 Recommended PCB Layout

The host PCB must be designed using the PCB footprint shown with the correct clearances. An example of the PCB layout shows the antenna footprint. Please note this clearance area is critical to the performance of the antenna and must be applied through all layers of the PCB.

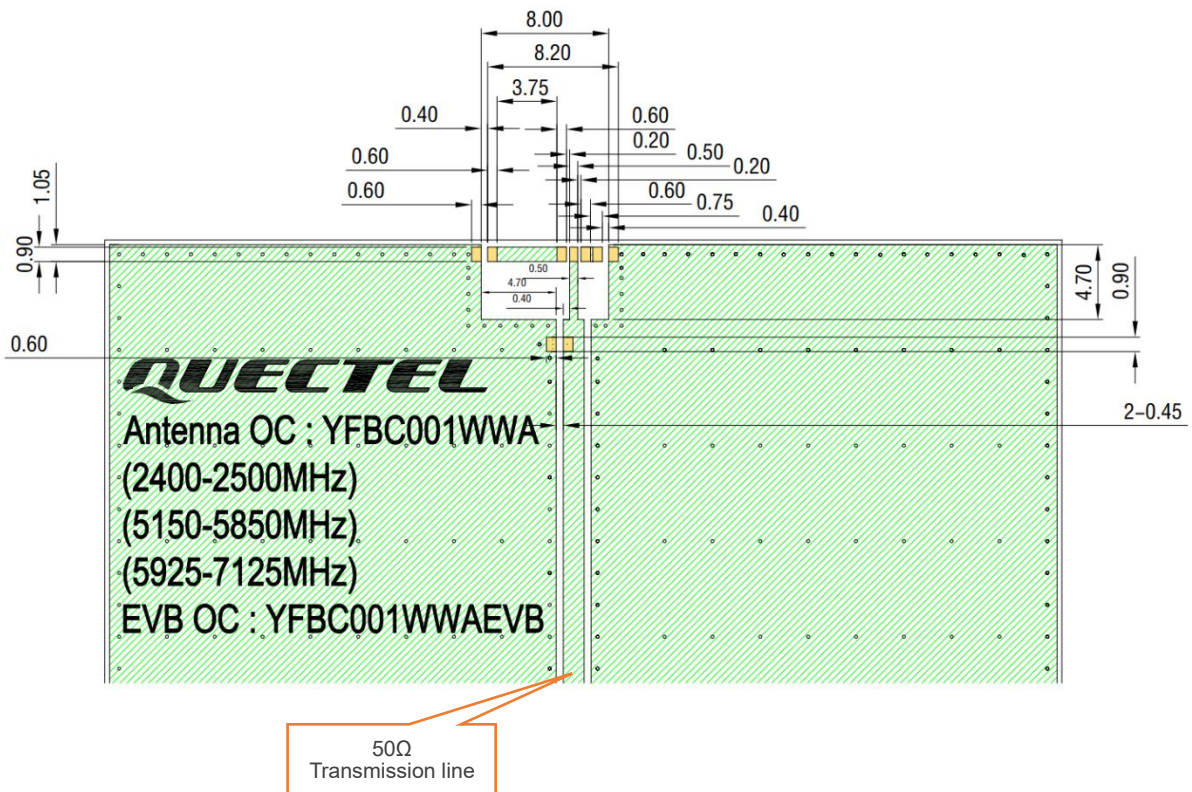

All dimensions in (mm)

7 Matching Circuit

Demo Board Top View



| | P1 | P2 | P3 |
|------------------|----------|----------|---------|
| Default Matching | 1.5 pF | 0.1 pF | 1.0 nH |
| Tolerance | ±0.25 pF | ±0.05 pF | ±0.1 nH |

8 Soldering Temperature

| Phase | Profile Features | PB-Free Assembly |
|-----------|--|--|
| RAMP-UP | Avg. Ramp-up Rate (T _{smax} to T _p) | 3 °C/second (Max.) |
| PREHEAT | Temperature Min (T _{smin}) Temperature Max (T _{smax}) Time (t _{smin} to t _{smax}) | 150 °C 200 °C 120 seconds (Max.) |
| REFLOW | Temperature (TL) Total Time above TL (tl) | 217 °C 90 seconds (Max.) |
| PEAK | Temperature (T _p) | 260 °C |
| RAMP-DOWN | Rate | 6 °C/second (Max.) |

9 Reflow Profile

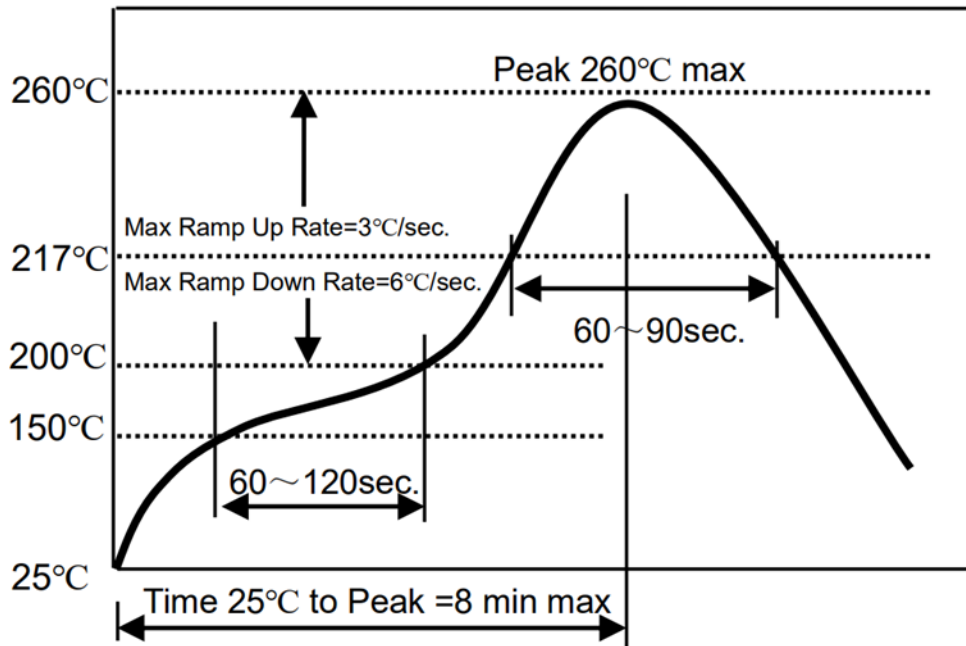

10 Packaging

| Step | Packaging Picture / 2D Picture | Description |
|------|--------------------------------|---|
| 1 | | Reel |
| 2 | | (4000 Antenna Products / Reel) One inner box contains 10 volumes. |
| 3 | | (6 Inner Boxes / Carton Box) (240000 Antennas / Carton Box) Estimated quantity Products that cannot fill the entire carton box are packed in a suitable size carton box. <u>Carton Size:</u> <u>L × W × H = 390 × 370 × 190 mm</u> |
| 4 | | Position for Attaching Labels ① Carton Label ② Quality Label |

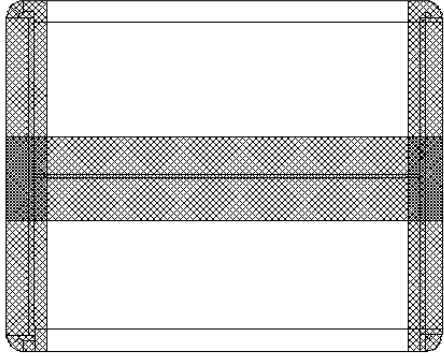
| | | |
|-------------|---|--|
| <p>5</p> |  | <p>Sealing Cartons H-shaped sealing cartons</p> |
| <p>Note</p> | <p>The initial packaging method described above is for reference only, and the final actual packaging method shall be subject to the actual shipping packaging.</p> | |

Contact Us

At Quectel, our aim is to provide timely and comprehensive services to our customers. If you require any assistance, please contact our headquarters:

Quectel Wireless Solutions Co., Ltd.

Building 5, Shanghai Business Park Phase III (Area B), No.1016 Tianlin Road, Minhang District, Shanghai 200233, China

Tel: +86 21 5108 6236

Email: info@quectel.com

Or our local offices. For more information, please visit:

<http://www.quectel.com/support/sales.htm>.

For technical support, or to report documentation errors, please visit:

<http://www.quectel.com/support/technical.htm>.

Or email us at: support@quectel.com.

Legal Notices

We offer information as a service to you. The provided information is based on your requirements and we make every effort to ensure its quality. You agree that you are responsible for using independent analysis and evaluation in designing intended products, and we provide reference designs for illustrative purposes only. Before using any hardware, software or service guided by this document, please read this notice carefully. Even though we employ commercially reasonable efforts to provide the best possible experience, you hereby acknowledge and agree that this document and related services hereunder are provided to you on an “as available” basis. We may revise or restate this document from time to time at our sole discretion without any prior notice to you.

Use and Disclosure Restrictions

License Agreements

Documents and information provided by us shall be kept confidential, unless specific permission is granted. They shall not be accessed or used for any purpose except as expressly provided herein.

Copyright

Our and third-party products hereunder may contain copyrighted material. Such copyrighted material shall not be copied, reproduced, distributed, merged, published, translated, or modified without prior written consent. We and the third party have exclusive rights over copyrighted material. No license shall be granted or conveyed under any patents, copyrights, trademarks, or service mark rights. To avoid ambiguities, purchasing in any form cannot be deemed as granting a license other than the normal non-exclusive, royalty-free license to use the material. We reserve the right to take legal action for noncompliance with abovementioned requirements, unauthorized use, or other illegal or malicious use of the material.

Trademarks

Except as otherwise set forth herein, nothing in this document shall be construed as conferring any rights to use any trademark, trade name or name, abbreviation, or counterfeit product thereof owned by Quectel or any third party in advertising, publicity, or other aspects.

Third-Party Rights

This document may refer to hardware, software and/or documentation owned by one or more third parties (“third-party materials”). Use of such third-party materials shall be governed by all restrictions and obligations applicable thereto.

We make no warranty or representation, either express or implied, regarding the third-party materials, including but not limited to any implied or statutory, warranties of merchantability or fitness for a particular purpose, quiet enjoyment, system integration, information accuracy, and non-infringement of any third-party intellectual property rights with regard to the licensed technology or use thereof. Nothing herein constitutes a representation or warranty by us to either develop, enhance, modify, distribute, market, sell, offer for sale, or otherwise maintain production of any our products or any other hardware, software, device, tool, information, or product. We moreover disclaim any and all warranties arising from the course of dealing or usage of trade.

Privacy Policy

To implement module functionality, certain device data are uploaded to Quectel's or third-party's servers, including carriers, chipset suppliers or customer-designated servers. Quectel, strictly abiding by the relevant laws and regulations, shall retain, use, disclose or otherwise process relevant data for the purpose of performing the service only or as permitted by applicable laws. Before data interaction with third parties, please be informed of their privacy and data security policy.

Disclaimer

- a) We acknowledge no liability for any injury or damage arising from the reliance upon the information.
- b) We shall bear no liability resulting from any inaccuracies or omissions, or from the use of the information contained herein.
- c) While we have made every effort to ensure that the functions and features under development are free from errors, it is possible that they could contain errors, inaccuracies, and omissions. Unless otherwise provided by valid agreement, we make no warranties of any kind, either implied or express, and exclude all liability for any loss or damage suffered in connection with the use of features and functions under development, to the maximum extent permitted by law, regardless of whether such loss or damage may have been foreseeable.
- d) We are not responsible for the accessibility, safety, accuracy, availability, legality, or completeness of information, advertising, commercial offers, products, services, and materials on third-party websites and third-party resources.

Copyright © Quectel Wireless Solutions Co., Ltd. 2025. All rights reserved.

Revision History

| Version | Date | Author | Note |
|---------|------------|--|---|
| - | 2024-06-17 | Sly LIU/ Lucky FENG/ David LIU/ Rainey LIAO | Creation of the document |
| 1.0 | 2024-06-17 | Sly LIU/ Lucky FENG/ David LIU/ Rainey LIAO | First official release |
| 2.0 | 2025-07-07 | Mayes LI/ Lucky FENG | Numerous changes were made to this document. It should be read in its entirety. |

QUECTEL

www.quectel.com