



Antenna Datasheet

Product OC: YEMN301J1AH

Version: 1.1

Date: 2026-01-26

Status: Released

Product Name: 5G & GNSS 3in1 Screw Mount Combo Antenna

Key Features:

Optimized for 5G and 4G Networks

Φ 103.5 mm × 42.5 mm

2 × 5G/4G MIMO + GPS L1 & L5

Screw Mount-M20

SMA Male Connector

IP Rating: IP67 & IP69K

RoHS & REACH Compliant

Compatible with ECE-R118 cables under demand

Overview

YEMN301J1AH is a 5G & GNSS 3in1 combo antenna measuring Φ 103.5 mm \times 42.5 mm. This ultra-wide-band 5G & GNSS antenna provides broad coverage from 600–960 MHz and 1400–6000 MHz whilst offering backward-compatibility to support 4G/3G and 2G networks as well as LTE Cat-M and narrowband IoT (NB-IoT). The antenna is available with connection via 3 cables lengths from 300–5,000 mm, terminated with SMA Male connectors. Ideal for applications where the antenna is required to be discrete this low profile, screw mount omni-directional antenna, is easy to install with maximum durability assured thanks to its IP67 & IP69K and IK09 rated enclosure. It is compatible with Quectel's RM520x Series modules.

YEMN301J1AH has 2 \times 5G LMH antennas and 1 \times GNSS L1 & L5 antenna. It allows high efficiency, stable signal transmission and reception for active GNSS from 1164–1189 MHz & 1565–1606 MHz, and 5G/4G bands from 600–960 MHz and 1400–6000 MHz. In the meantime, this product also offers high isolation between antennas to avoid self-interference. All in all, this unique product is designed to provide stable and high-speed data connection to 5G & GNSS applications. The YEMN301J1AH can be used in harsh environments thanks to its robust UV resistant (UL 746c f1) and flame resistant (UL 94 V-0) enclosure.

- **Typical Applications Include:**

- ✓ Smart Utilities and Buildings
- ✓ Digital Signage
- ✓ Warehouses & Logistic systems
- ✓ Industrial factory automation, robotic machinery and other M2M systems
- ✓ Transport (Busses, Utility & Public Safety)
- ✓ Mining Vehicles & Machinery communications, telemetry and automation

Quectel provides comprehensive antenna design support such as simulation, testing and manufacturing for custom antenna solutions to meet your specific application needs. We have regional R & D centers to offer quick response to meet your requirements. Please contact our sales & FAEs if you have any requests.

Contents

Overview.....	1
Contents.....	2
1 Specification.....	3
1.1 Electrical.....	3
1.1.1 LMHs.....	4
1.1.2 GNSS.....	5
1.2 Mechanical & Environment.....	6
1.3 Supported Bands.....	7
1.4 Block Diagram (Active Antenna).....	11
2 Drawing.....	12
3 Detailed Performance.....	13
3.1 S-Parameter Test.....	13
3.1.1 VSWR.....	13
3.1.2 Return Loss.....	15
3.1.3 Isolation.....	17
3.1.3.1 Test Status: In Free Space.....	17
3.1.3.2 Test Status: On 320 mm × 240 mm Metal Plane.....	17
3.1.4 GNSS LNA Gain.....	19
3.1.5 GNSS Noise Figure.....	20
3.2 Radiation Performance Test.....	21
3.2.1 Efficiency.....	21
3.2.2 Average Gain.....	23
3.2.3 Peak Gain.....	24
3.2.4 3D & 2D Radiation Pattern.....	26
3.2.4.1 Test Status: In Free Space.....	26
3.2.4.2 Test Status: On 320 mm × 240 mm Metal Plane.....	36
4 Packaging.....	45
5 Installation.....	47
6 Appendix Reference.....	48
Contact Us.....	50
Legal Notices.....	51
Revision History.....	53

1 Specification

Test Condition: In Free Space & On 320 mm × 240 mm Metal Plane

1.1 Electrical

Electrical Specifications		
Frequency Range	LMHS	600–960 MHz, 1400–6000 MHz
	GNSS	1164–1189 MHz, 1565–1606 MHz
Radiation Pattern	LMHS	Omni-directional
	GNSS	Directional
Polarization	LMHS	Linear
	GNSS	RHCP
Impedance		50 Ω
Isolation		≤ -9.2 dB

1.1.1 LMHs

SPEC	Band	B71	B12 /B13 /B28	B5 /B8 /B26	n74 /n75 /n76	B1 /B2 /B3	B40	Wi-Fi 2G	B38 /B41	B42 /B48 /n77	n79	Wi-Fi 5G
	Freq. (MHz)	600– 700	700– 810	820– 960	1420– 1520	1700– 2170	2300– 2400	2400– 2500	2500– 2690	3300– 4200	4400– 5000	5150– 5850
Max VSWR	FS	9.5	2.4	5.7	2.0	1.4	1.4	1.3	1.3	2.5	1.9	1.7
	MP	8.5	3.7	5.3	2.1	1.9	1.6	1.5	1.4	2.8	2.0	1.9
Max Return Loss (dB)	FS	-1.8	-7.7	-3.1	-9.5	-15.6	-15.6	-17.7	-17.7	-7.4	-10.2	-11.7
	MP	-2.1	-4.8	-3.3	-9.0	-10.2	-12.7	-14.0	-15.6	-6.5	-9.5	-10.2
AVG Eff. (%)	FS	20.9	37.2	28.8	55.2	69.8	73.9	73.3	66.6	60.4	55.2	46.7
	MP	14.0	39.0	34.7	50.0	64.7	60.4	64.9	57.4	48.0	48.2	44.2
AVG AVG Gain (dB)	FS	-7.1	-4.4	-5.6	-2.6	-1.6	-1.3	-1.3	-1.8	-2.2	-2.6	-3.3
	MP	-9.0	-4.2	-4.7	-3.1	-1.9	-2.2	-1.9	-2.4	-3.3	-3.2	-3.5
Max Peak Gain (dBi)	FS	-1.7	0.5	0.1	1.6	2.0	1.6	2.0	2.5	5.0	3.9	3.7
	MP	-2.5	2.7	2.3	4.6	5.9	4.8	5.5	5.5	6.2	5.3	4.6
VSWR	FS	≤ 9.2										
	MP	≤ 8.5										
Return Loss	FS	≤ -1.9 dB										
	MP	≤ -2.0 dB										
Peak Gain	FS	≤ 5.0 dBi										
	MP	≤ 6.2 dBi										

- LMHs: LMH antennas
- FS: In Free Space
- MP: On 320 mm × 240 mm Metal Plane

1.1.2 GNSS

Band	GPS L5 GALILEO E5a BDS B2a- B2I QZSS L5 IRNSS L5	GALILEO E5b BDS B2b	GPS L2 QZSS L2C	GLONASS G2	BDS B3	BDS B1I	GPS L1 GALILEO E1 BDS B1C QZSS L1	GLONASS G1
Frequency (MHz)	1176	1207	1227	1248	1268	1561	1575	1602
VSWR	1.61	-	-	-	-	-	1.52	1.49
Return Loss (dB)	-12.8	-	-	-	-	-	-13.6	-14
Efficiency (%)	47	-	-	-	-	-	42	40
Peak Gain (dBi)	-0.04	-	-	-	-	-	-1.49	-1.17

LNA Electrical	
LNA Gain	28 ±3 dB
Noise Figure	≤ 2.5 dB
Output VSWR	< 2.0
Filter Out-of-Band Attenuation	65 dB f0 ±100 MHz f0 (1176 MHz, 1588 MHz)
Working Voltage	DC 2–5 V
Working Current	12.3 ±3 mA
Impedance	50 Ω

1.2 Mechanical & Environment

Mechanical	
Antenna Size	
Φ 103.5 mm × 42.5 mm	
Casing Material & Color	
PC & Black	
Cable Type & Length	LMHs
	GNSS
RG405 Black & 300 mm	
RG174 Black & 300 mm	
Connector Type	
SMA Male (The current state of the SMA connector is not waterproof. If a waterproof connector is required, it can be customized.)	
Weight	
Typ. 210 g	
Mounting Type	
Screw Mounting (M20)	
Environmental	
Operation Temperature	
-40 °C to +85 °C	
Storage Temperature	
-40 °C to +85 °C	
Ingress Protection (IP) Rating	
IP67 (After Installation) IP69K (After Installation)	
Impact Protection (IK) Rating	
IK09	
RoHS & REACH Compliant	
Yes	
Housing Flame Rating	
UL 94 V-0	
Housing UV Resistant	
UL 746c f1	

- LMHs: LMH antennas
- FS: In Free Space
- MP: On 320 mm × 240 mm Metal Plane

1.3 Supported Bands

5G NR/ LTE/ LTE-Advanced/ WCDMA/ HSPA/ HSPA+/ GPRS/ GSM/ NB-IoT				
Band	Frequency (MHz)	Uplink (MHz)	Downlink (MHz)	LMHs
1	2100	1920–1980	2110–2170	√
2	1900	1850–1910	1930–1990	√
3	1800	1710–1785	1805–1880	√
4	1700	1710–1755	2110–2155	√
5	850	824–849	869–894	√
7	2600	2500–2570	2620–2690	√
8	900	880–915	925–960	√
9	1800	1749.9–1784.9	1844.9–1879.9	√
11	1500	1427.9–1447.9	1475.9–1495.9	√
12	700	699–716	729–746	√
13	700	777–787	746–756	√
14	700	788–798	758–768	√
17	700	704–716	734–746	√
18	850	815–830	860–875	√
19	850	830–845	875–890	√
20	800	832–862	791–821	√
21	1500	1447.9–1462.9	1495.9–1510.9	√
22	3500	3410–3490	3510–3590	√
23	2100	2000–2020	2180–2200	√
24	1600	1626.5–660.5	1525–1559	√
25	1900	1850–1915	1930–1995	√
26	850	814–849	859–894	√

5G NR/ LTE/ LTE-Advanced/ WCDMA/ HSPA/ HSPA+/ GPRS/ GSM/ NB-IoT				
Band	Frequency (MHz)	Uplink (MHz)	Downlink (MHz)	LMHs
28	700	703–748	758–803	√
31	450	452.5–457.5	462.5–467.5	-
34	2100	2010–2025		√
38	2600	2570–2620		√
39	1900	1880–1920		√
40	2300	2300–2400		√
41	2500	2496–2690		√
42	3500	3400–3600		√
48	3500	3550–3700		√
66	1700	1710–1780	2110–2200	√
71	600	663–698	617–652	√
74	1500	1427–1470	1475–1518	√
77	3500	3300–4200		√
78	3500	3300–3800		√
79	4500	4400–5000		√

GNSS Frequency Bands (MHz)					
GPS	L1 Centre 1575.42 (1565–1586)	L2 Centre 1227.6 (1217–1238)	L5 Centre 1176.45 (1164–1189)		
	√	-	√		
GLONASS	G1-L10C-L10F Centre 1601 (1595–1606)	G2-L20C-L20F Centre 1248.06 (1241–1255)	G3-L30C Centre 1202.025 (1189–1213)		
	√	-	-		
GALILEO	E1 Centre 1575.42 (1563–1588)	E5a Centre 1176.45 (1166–1187)	E5b Centre 1207.14 (1197–1218)	E6 Centre 1278.75 (1258–1300)	
	√	√	-	-	
BDS	B1I Centre 1561.098 (1559–1564)	B1C (BDS-3) Centre 1575.42 (1559–1592)	B2a-B2I Centre 1176.45 (1166–1187)	B2b Centre 1207.14 (1197–1217)	B3 Centre 1268.52 (1258–1279)
		√	√	-	-
QZSS	L1 Centre 1575.42 (1573–1578)	L2C Centre 1227.6 (1226–1229)	L5 Centre 1176.45 (1166–1187)	L6 Centre 1278.75 (1257–1300)	
	√	-	√	-	
IRNSS	L5 Centre 1176.45 (1164–1189)				
	√				

GNSS Bands and Constellations

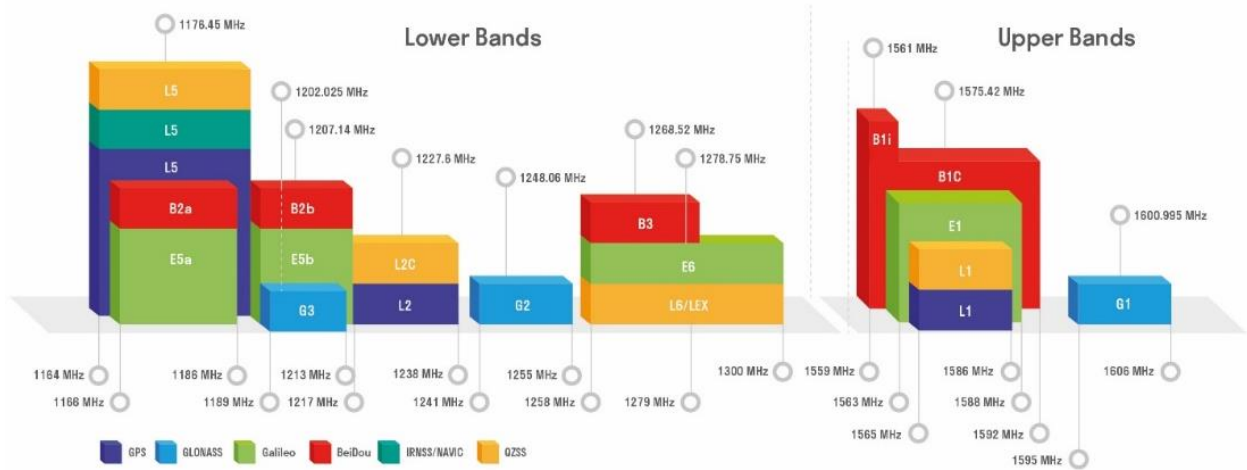

1.4 Block Diagram (Active Antenna)

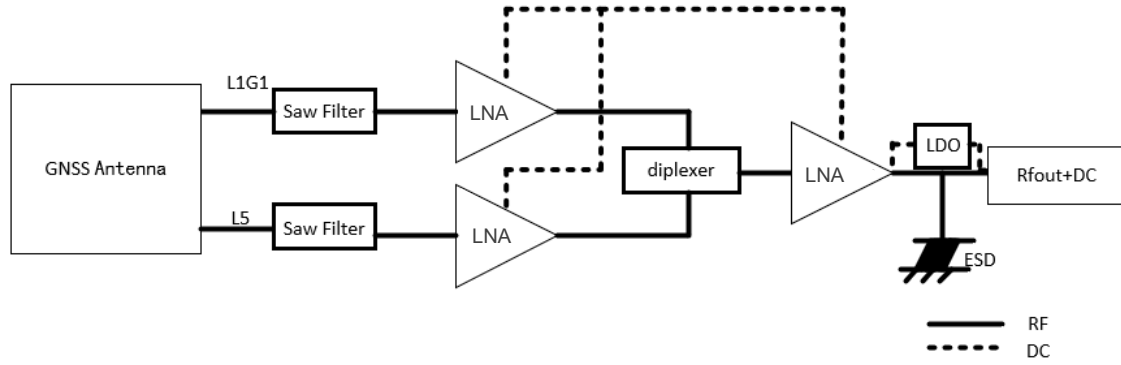

2 Drawing

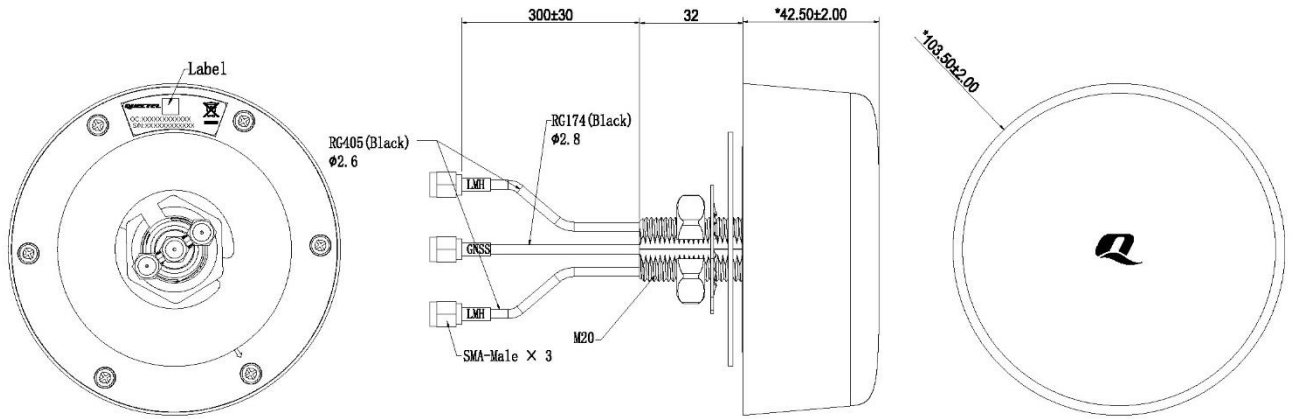

3 Detailed Performance

3.1 S-Parameter Test

3.1.1 VSWR

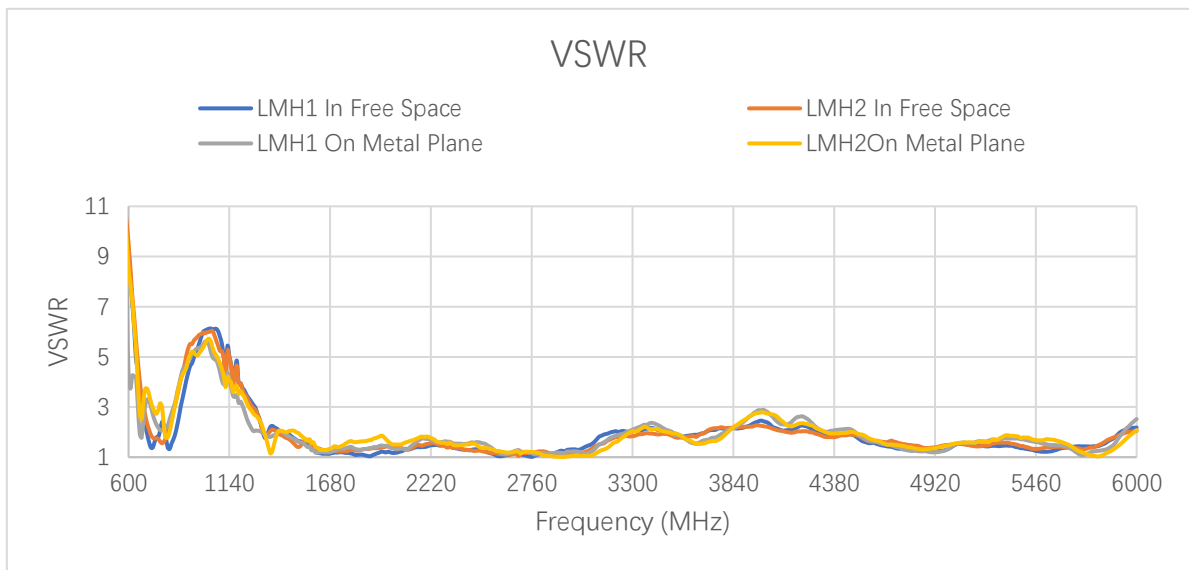

VSWR – LMHs

Frequency (MHz)		600	630	710	830	900	960	1440	1710	1740	1880
LMH1	FS	9.2	6.2	1.6	1.5	3.7	5.2	2.0	1.2	1.2	1.1
	MP	4.2	4.2	3.2	2.7	4.6	5.3	1.9	1.3	1.3	1.3
LMH2	FS	9.5	6.6	2.1	2.6	4.7	5.7	1.8	1.2	1.2	1.3
	MP	8.5	6.3	3.5	2.4	4.4	5.1	2.0	1.4	1.4	1.7
Frequency (MHz)		1950	2140	2350	2450	2600	3600	4700	5000	5500	6000
LMH1	FS	1.2	1.4	1.4	1.3	1.0	1.2	1.4	1.4	1.2	2.2
	MP	1.5	1.6	1.5	1.6	1.1	1.3	1.4	1.4	1.5	2.5
LMH2	FS	1.4	1.5	1.4	1.2	1.1	1.0	1.6	1.5	1.4	2.0
	MP	1.8	1.7	1.5	1.5	1.2	1.2	1.5	1.5	1.7	2.1

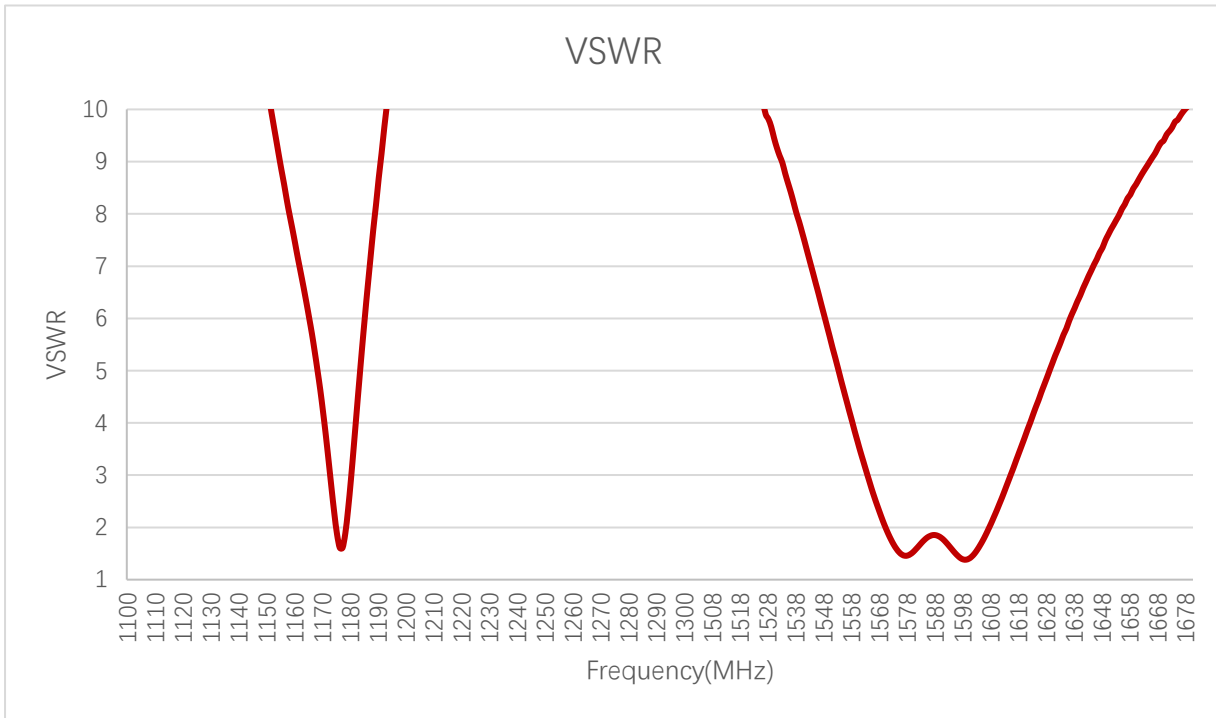

VSWR – GNSS

Frequency (MHz)	1176	1207	1227	1248	1268	1561	1575	1602
VSWR	1.61	-	-	-	-	-	1.52	1.49

3.1.2 Return Loss

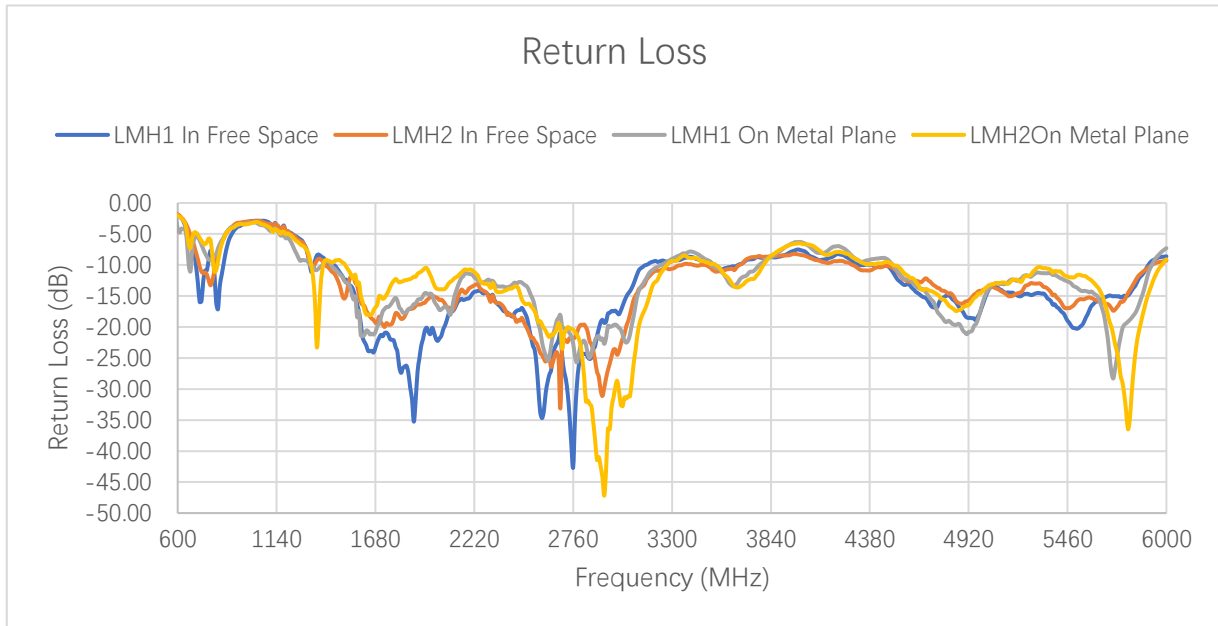

Return Loss (dB) – LMHs

Frequency (MHz)		600	630	710	830	900	960	1440	1710	1740	1880
LMH1	FS	-1.9	-2.8	-12.8	-13.4	-4.8	-3.4	-9.8	-21.3	-20.9	-31.7
	MP	-4.2	-4.2	-5.6	-6.6	-3.9	-3.3	-10.1	-18.5	-16.8	-16.7
LMH2	FS	-1.8	-2.6	-9.0	-6.9	-3.8	-3.1	-11.0	-19.2	-19.4	-17.0
	MP	-2.0	-2.8	-5.1	-7.9	-4.0	-3.5	-9.6	-15.1	-14.8	-12.1
Frequency (MHz)		1950	2140	2350	2450	2600	3600	4700	5000	5500	6000
LMH1	FS	-20.5	-15.7	-16.4	-17.4	-33.5	-21.1	-15.9	-16.2	-20.2	-8.6
	MP	-14.5	-12.7	-13.5	-13.1	-23.7	-18.1	-14.9	-15.7	-13.5	-7.3
LMH2	FS	-16.1	-14.5	-16.1	-19.2	-25.1	-33.1	-12.5	-14.0	-16.3	-9.3
	MP	-10.5	-11.5	-14.4	-13.4	-20.2	-20.0	-14.0	-14.1	-11.9	-9.1

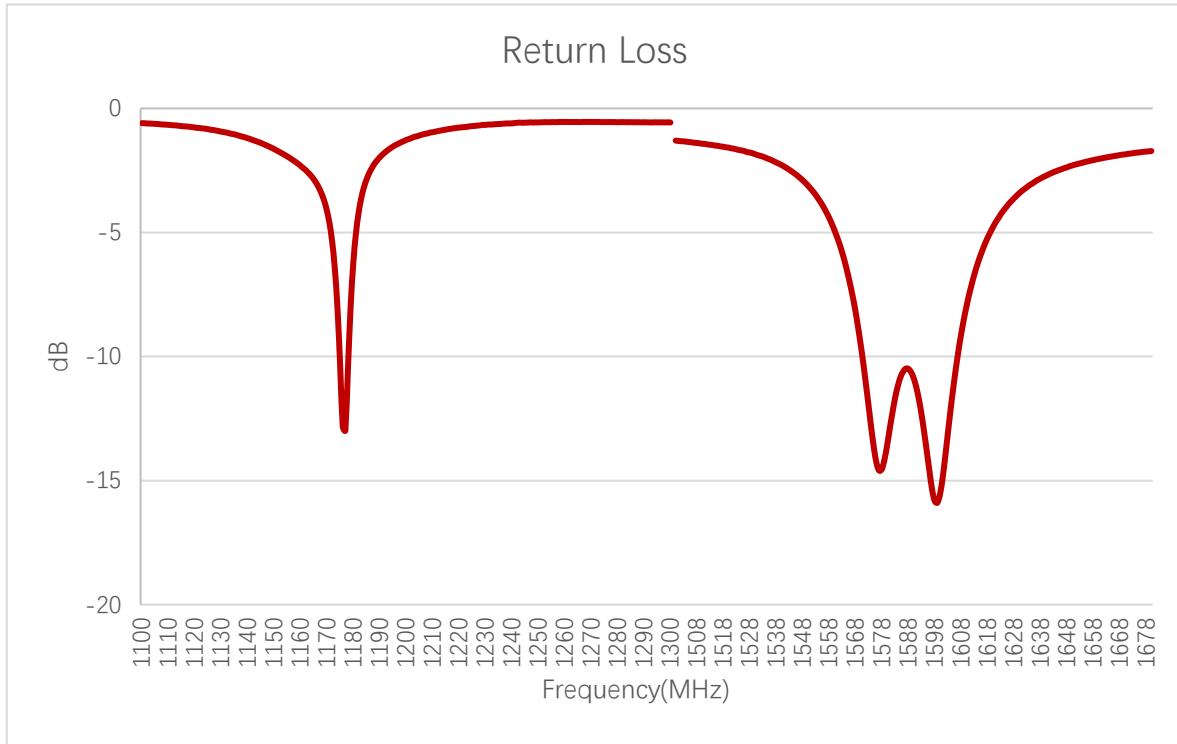

Return Loss (dB) – GNSS

Frequency (MHz)	1176	1207	1227	1248	1268	1561	1575	1602
Return Loss (dB)	-12.8	-	-	-	-	-	-13.6	-14

3.1.3 Isolation

3.1.3.1 Test Status: In Free Space

3.1.3.1.1 LMH1

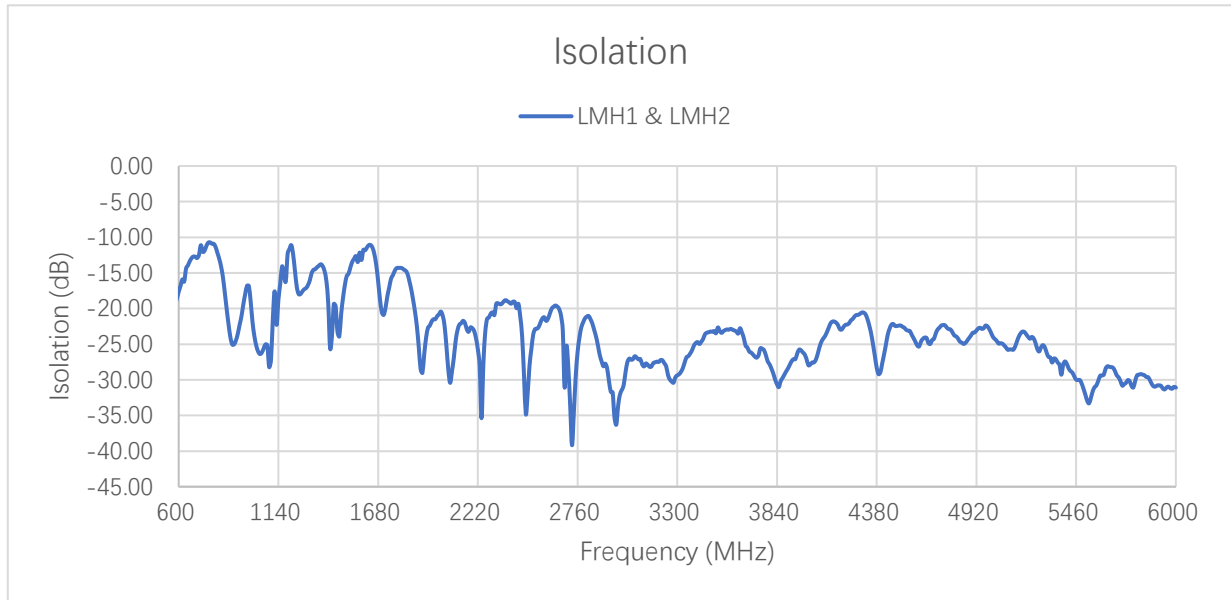

3.1.3.2 Test Status: On 320 mm × 240 mm Metal Plane

3.1.3.2.1 LMH1

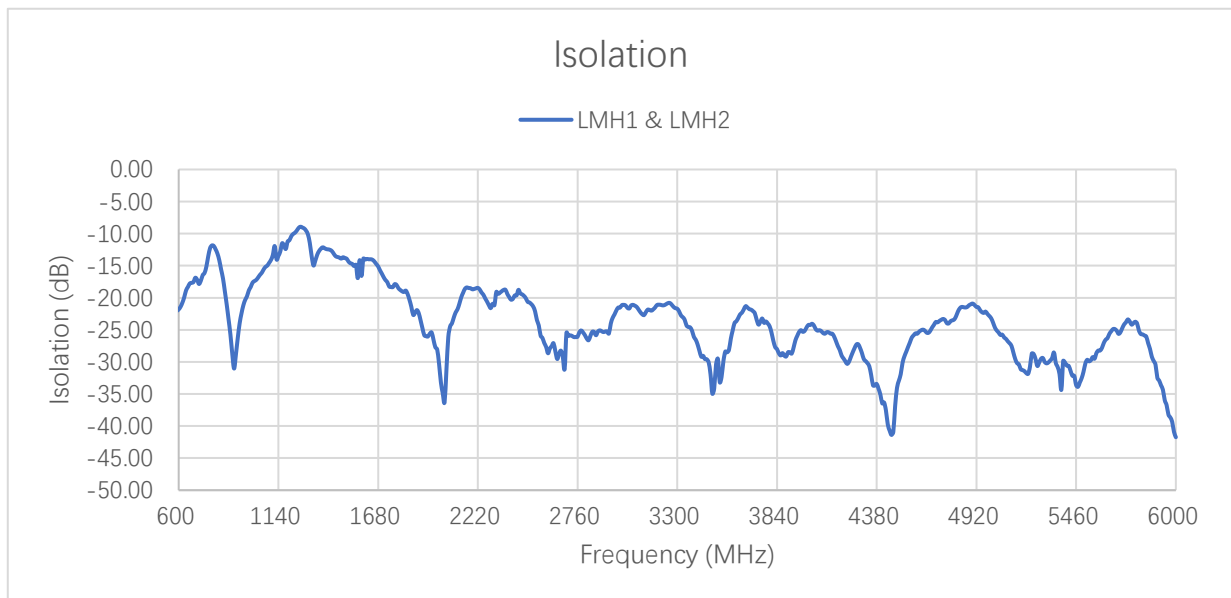

Max Isolation (dB)

	Band	B71	B12/ B13/ B28	B5/ B8/ B26	n74/ n75/ n76	B1/ B2/ B3	B40	Wi-Fi 2G	B38/ B41	B42/ B48/ n77	n79	Wi-Fi 5G
	Freq. (MHz)	600– 700	700– 810	820– 960	1420– 1520	1700– 2170	2300– 2400	2400– 2500	2500– 2690	3300– 4200	4400– 5000	5150– 5850
LMH1 & LMH2	FS	-12.7	-10.7	-13.1	-15.1	-14.3	-18.8	-19.0	-19.6	-21.8	-22.2	-23.2
	MP	-16.9	-11.8	-14.2	-12.5	-16.8	-18.8	-18.8	-20.7	-21.3	-20.9	-23.2

- FS: In Free Space
- MP: On 320 mm × 240 mm Metal Plane

3.1.4 GNSS LNA Gain

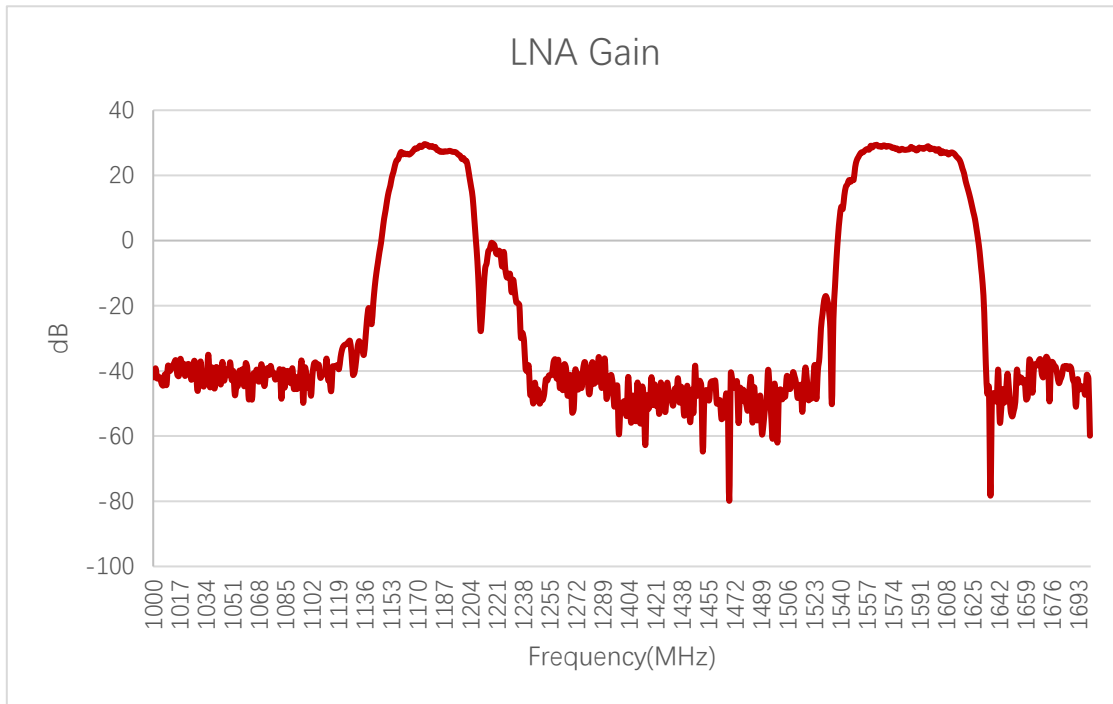

LNA Gain (dB)

Frequency (MHz)	1176	1207	1227	1248	1268	1561	1575	1602
LNA Gain (dB)	29.3	-	-	-	-	-	28.1	27.9

3.1.5 GNSS Noise Figure

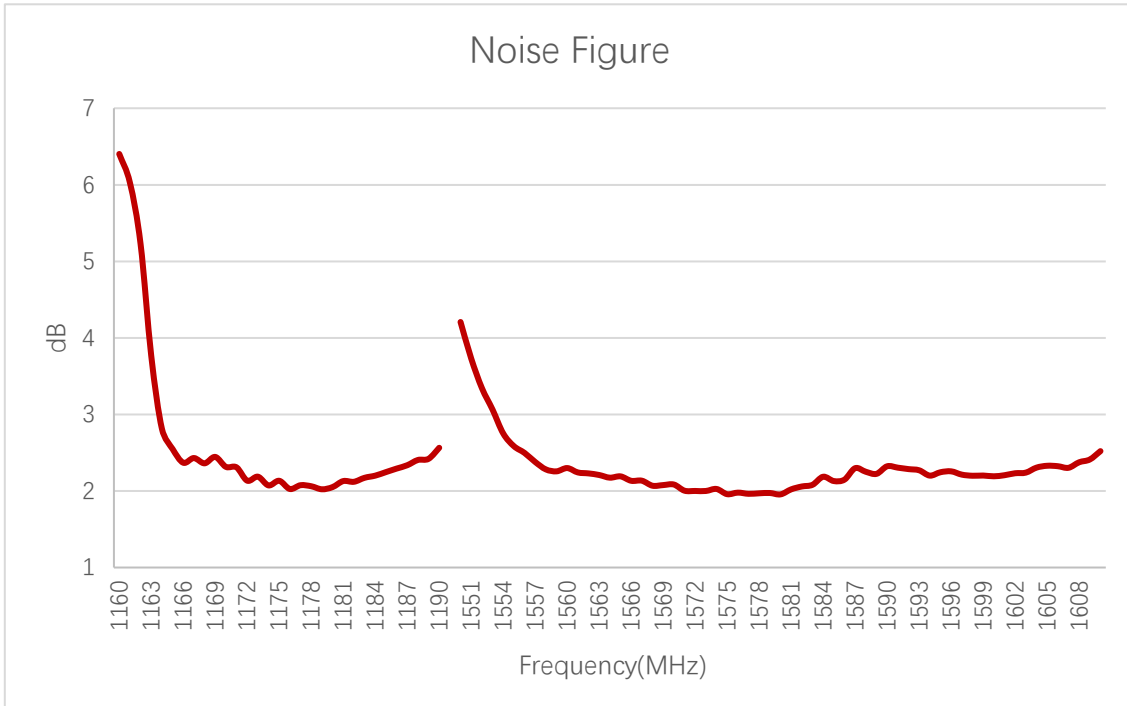

Noise Figure (dB)

Frequency (MHz)	1176	1207	1227	1248	1268	1561	1575	1602
Noise Figure (dB)	2.02	-	-	-	-	-	1.95	2.23

3.2 Radiation Performance Test

3.2.1 Efficiency

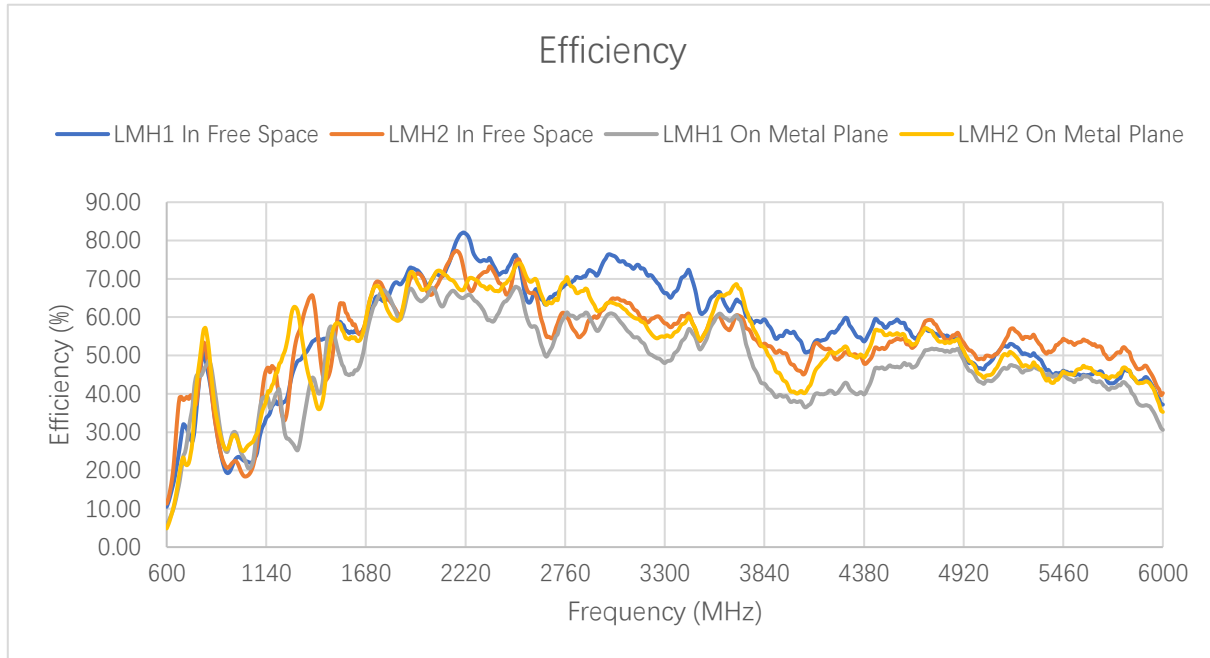

Efficiency (%) – LMHs

Frequency (MHz)		600	630	710	830	900	960	1440	1710	1740	1880
LMH1	FS	10.5	15.4	30.8	44.1	22.9	21.7	54.1	62.2	65.4	69.3
	MP	6.1	9.1	27.5	48.6	28.1	29.9	41.5	60.9	64.5	60.9
LMH2	FS	11.3	18.1	39.2	45.9	23.3	22.2	46.6	65.7	69.3	62.1
	MP	4.9	9.1	21.4	51.1	27.6	29.1	37.2	65.8	68.2	62.5
Frequency (MHz)		1950	2140	2350	2450	2600	3600	4700	5000	5500	6000
LMH1	FS	72.4	75.4	75.5	73.0	67.3	66.4	56.4	46.7	45.5	37.2
	MP	65.5	66.6	59.3	64.8	57.5	60.9	50.4	43.3	43.7	30.6
LMH2	FS	71.1	75.4	73.3	66.1	65.8	60.1	57.6	49.0	53.6	40.2
	MP	70.1	69.8	68.0	69.5	70.0	65.7	56.3	45.3	45.1	35.3

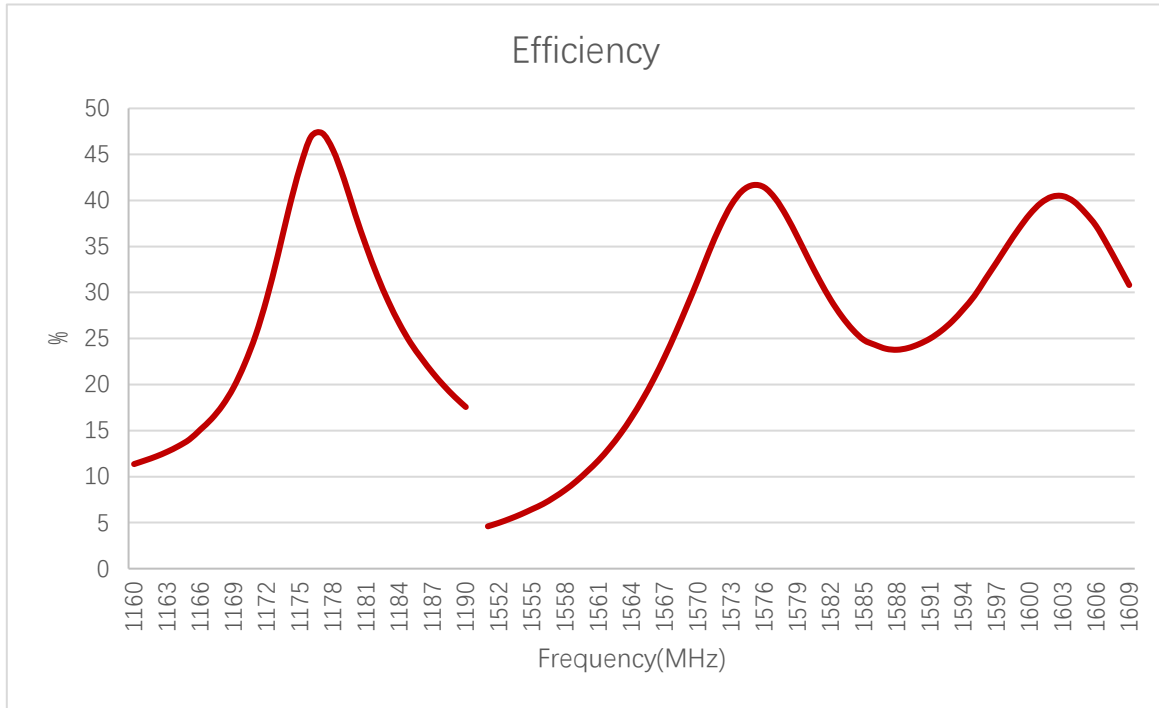

Efficiency (%) – GNSS

Frequency (MHz)	1176	1207	1227	1248	1268	1561	1575	1602
Efficiency (%)	47	-	-	-	-	-	42	40

3.2.2 Average Gain

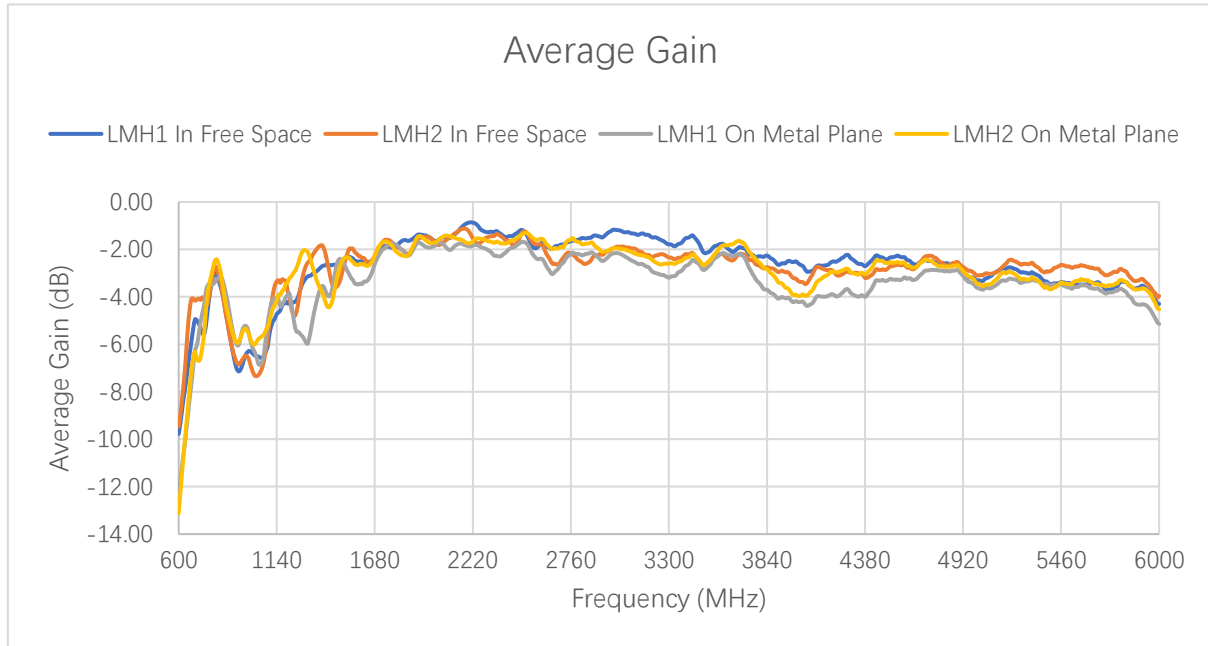

Average Gain (dB) – LMHs

Frequency (MHz)		600	630	710	830	900	960	1440	1710	1740	1880
LMH1	FS	-9.8	-8.1	-5.1	-3.6	-6.4	-6.6	-2.7	-2.1	-1.8	-1.6
	MP	-12.1	-10.4	-5.6	-3.1	-5.5	-5.3	-3.8	-2.2	-1.9	-2.2
LMH2	FS	-9.5	-7.4	-4.1	-3.4	-6.3	-6.6	-3.3	-1.8	-1.6	-2.1
	MP	-13.1	-10.4	-6.7	-2.9	-5.6	-5.4	-4.3	-1.8	-1.7	-2.0
Frequency (MHz)		1950	2140	2350	2450	2600	3600	4700	5000	5500	6000
LMH1	FS	-1.4	-1.2	-1.2	-1.4	-1.7	-1.8	-2.5	-3.3	-3.4	-4.3
	MP	-1.8	-1.8	-2.3	-1.9	-2.4	-2.2	-3.0	-3.6	-3.6	-5.1
LMH2	FS	-1.5	-1.2	-1.4	-1.8	-1.8	-2.2	-2.4	-3.1	-2.7	-4.0
	MP	-1.5	-1.6	-1.7	-1.6	-1.6	-1.8	-2.5	-3.4	-3.5	-4.5

3.2.3 Peak Gain

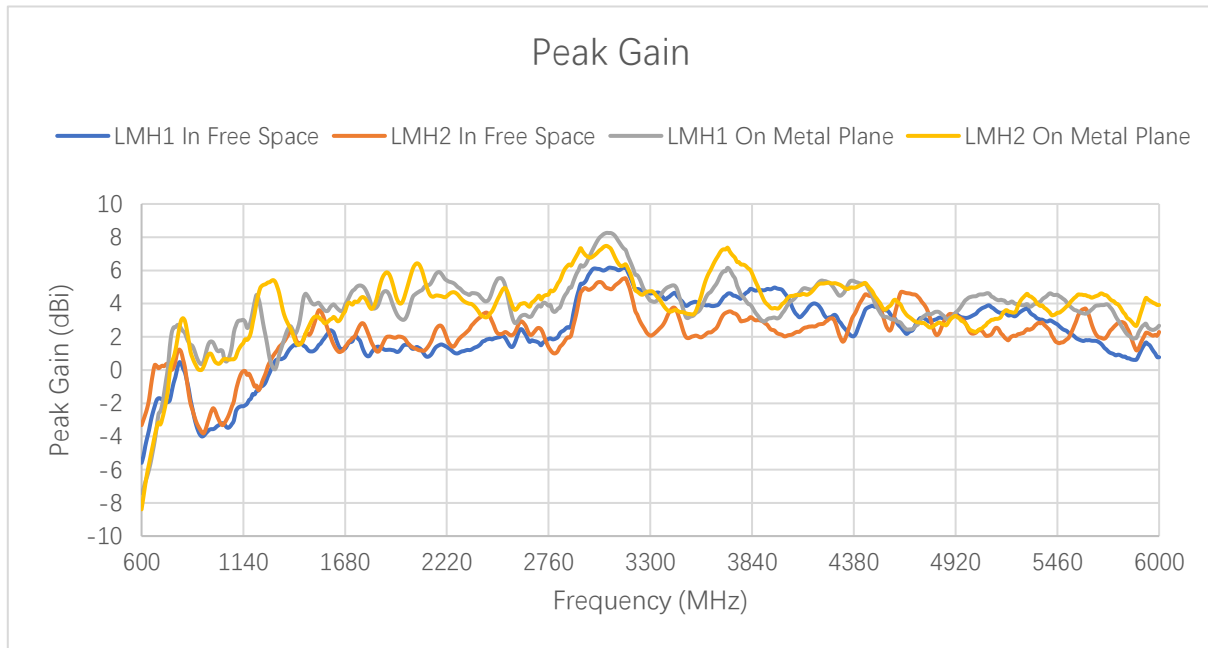

Peak Gain (dBi) – LMHs

Frequency (MHz)		600	630	710	830	900	960	1440	1710	1740	1880
LMH1	FS	-5.6	-4.1	-1.8	-0.1	-3.7	-3.6	1.6	1.7	2.0	1.3
	MP	-7.4	-6.4	-2.1	2.2	0.6	1.7	3.0	4.6	5.0	4.6
LMH2	FS	-3.3	-2.3	0.3	0.2	-3.4	-2.8	1.6	1.8	2.2	1.6
	MP	-8.4	-6.2	-2.9	3.0	0.1	1.0	1.5	4.0	4.1	5.6
Frequency (MHz)		1950	2140	2350	2450	2600	3600	4700	5000	5500	6000
LMH1	FS	1.1	1.0	1.2	1.9	2.2	3.9	2.6	3.2	2.4	0.8
	MP	3.5	5.3	4.6	4.4	3.0	4.5	2.6	4.4	4.2	2.7
LMH2	FS	2.0	1.8	2.7	3.2	2.7	2.2	4.6	2.2	1.8	2.3
	MP	4.5	4.4	4.0	3.4	3.8	5.6	3.0	2.4	3.7	3.9

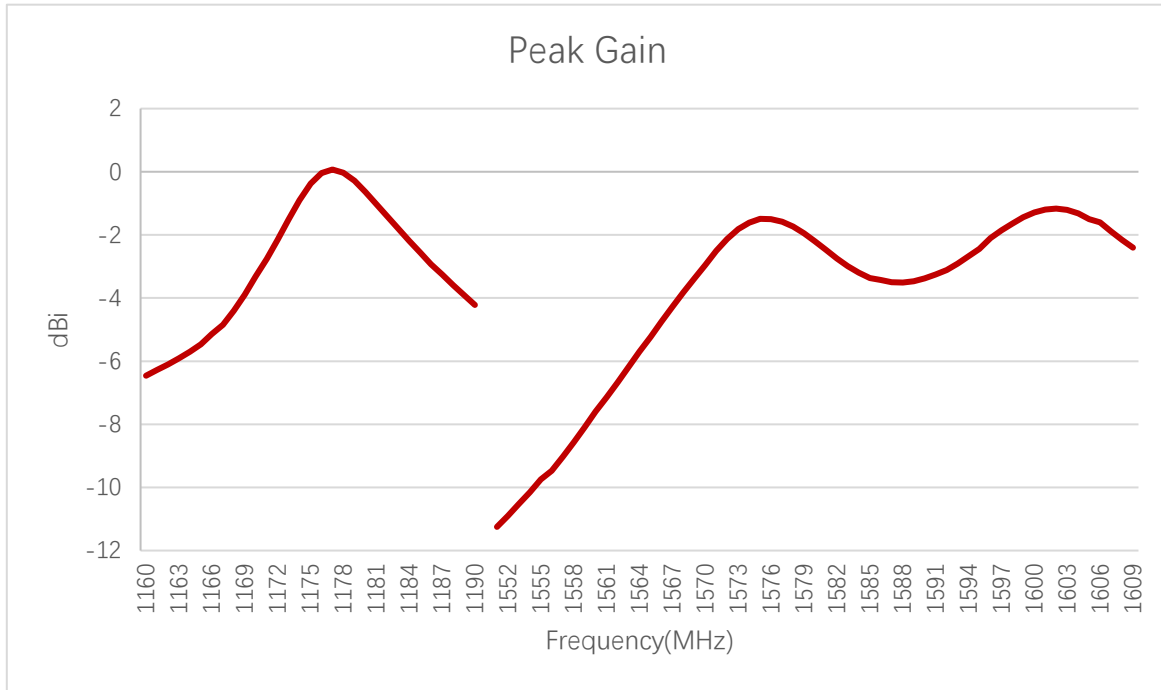

Peak Gain (dBi) – GNSS

Frequency (MHz)	1176	1207	1227	1248	1268	1561	1575	1602
Peak Gain (dBi)	-0.04	-	-	-	-	-	-1.49	-1.17

3.2.4 3D & 2D Radiation Pattern

3.2.4.1 Test Status: In Free Space

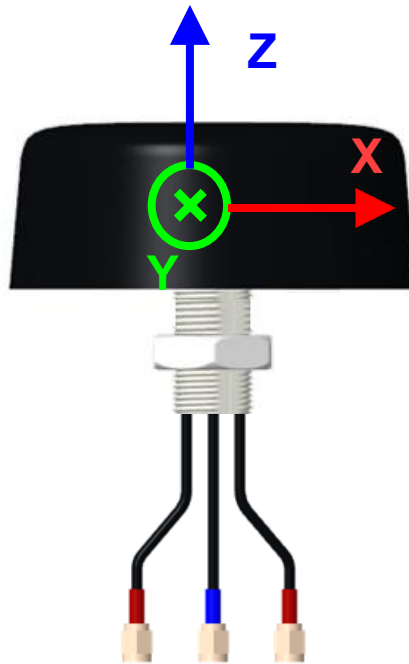

LMH1

630 MHz

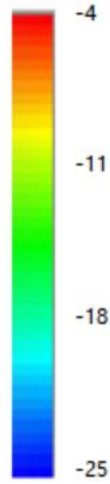
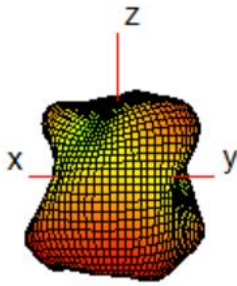

710 MHz

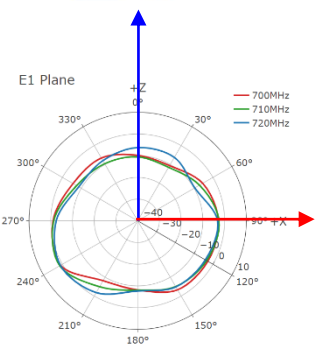
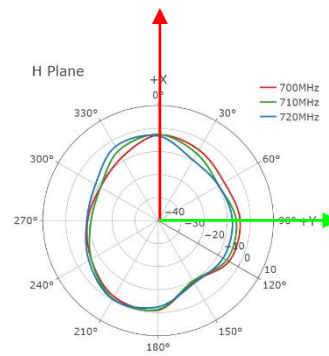
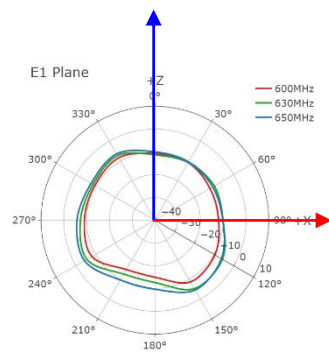
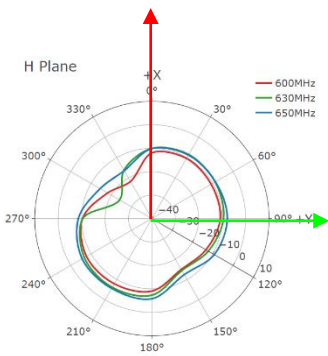
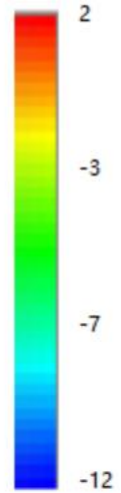
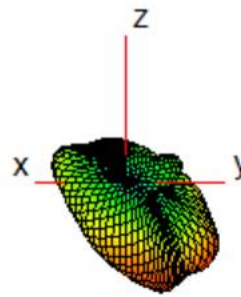

830 MHz

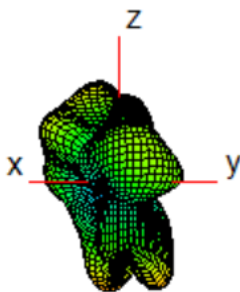

900 MHz

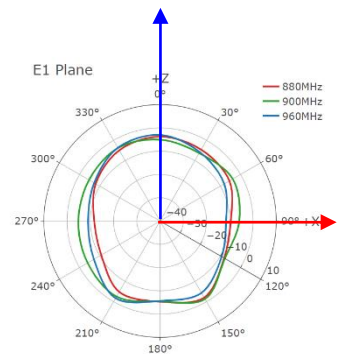
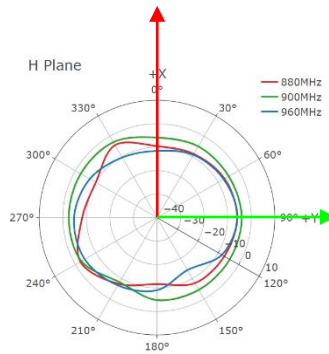
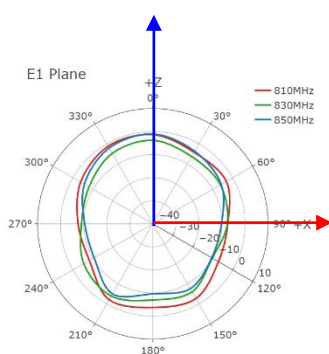
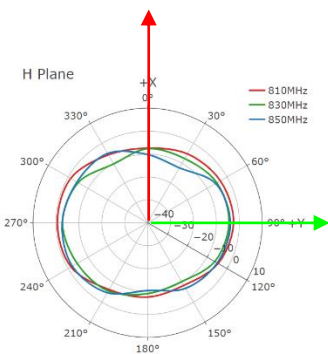
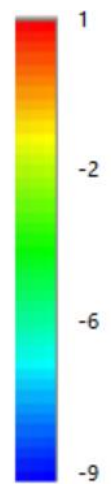
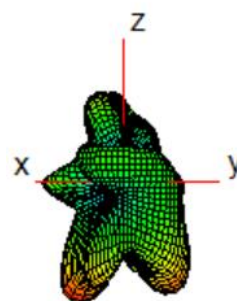

● **LMH1**

1440 MHz

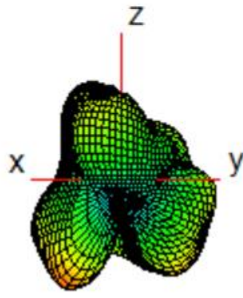

1740 MHz

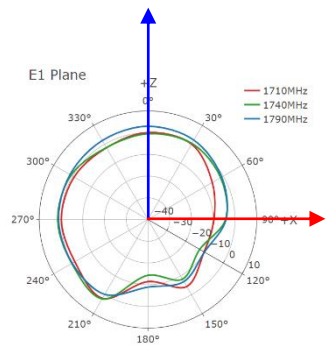
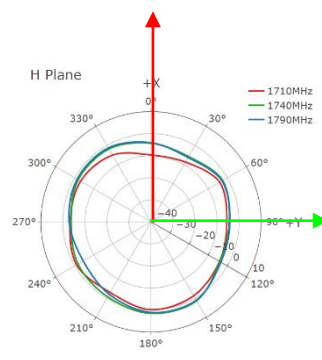
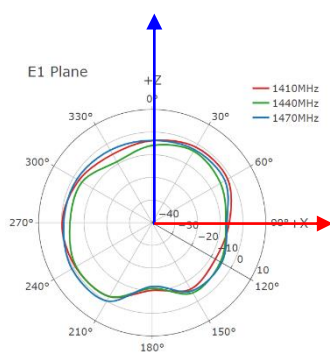
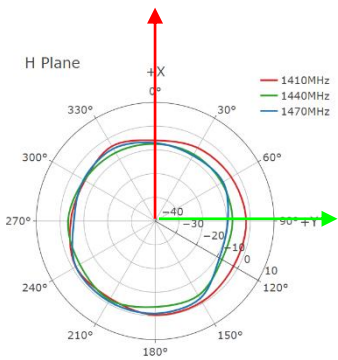
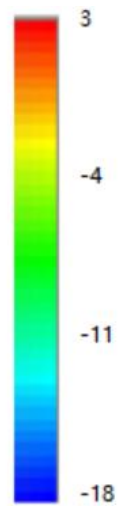
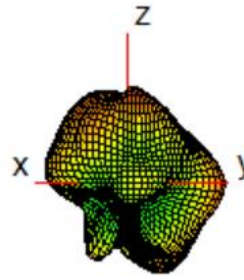

1880 MHz

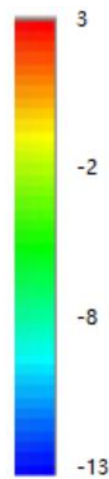
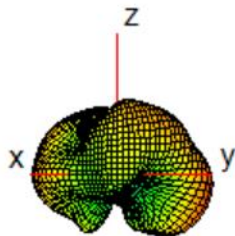

1960 MHz

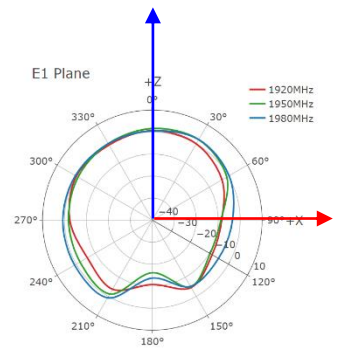
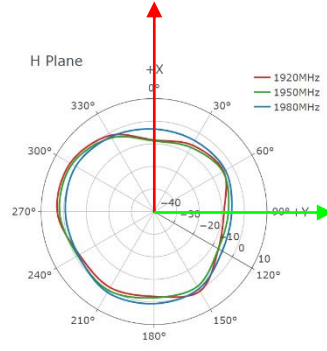
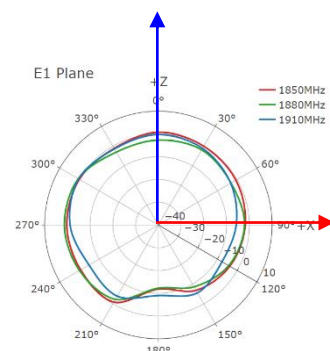
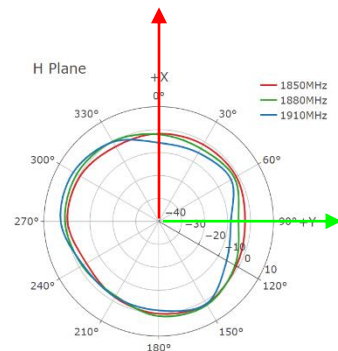
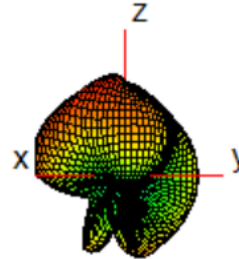

● **LMH1**

2140 MHz

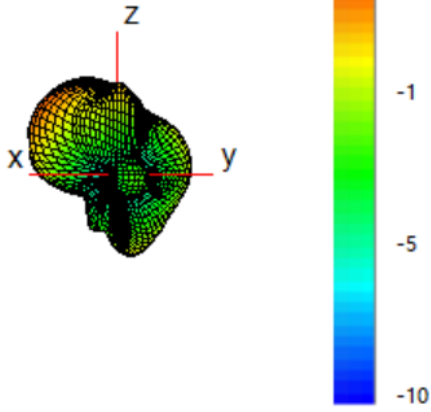

2350 MHz

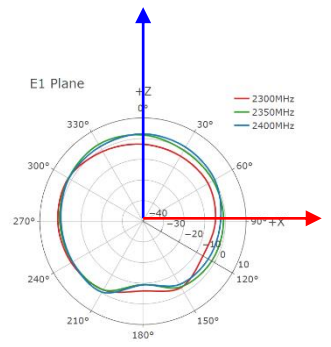
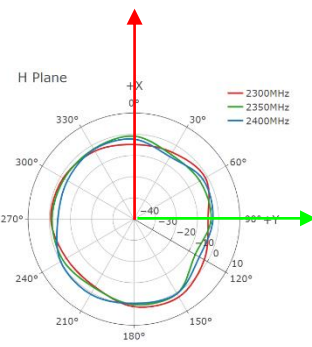
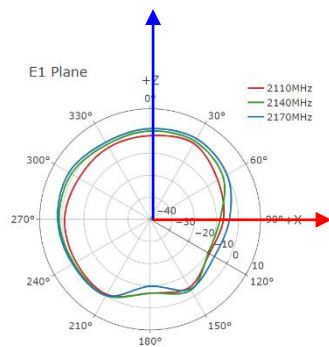
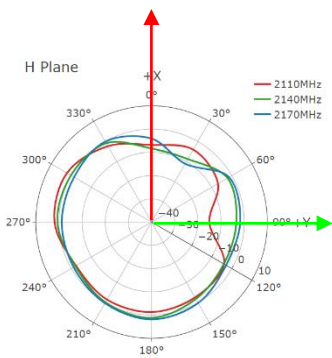
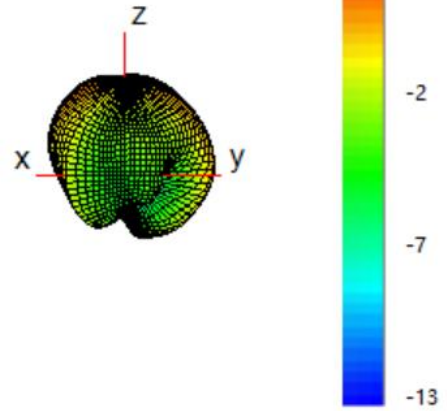

2450 MHz

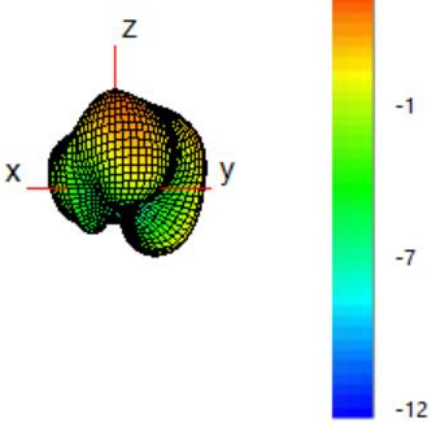

2600 MHz

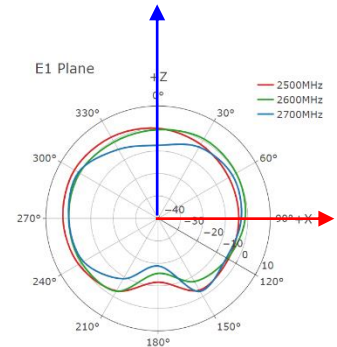
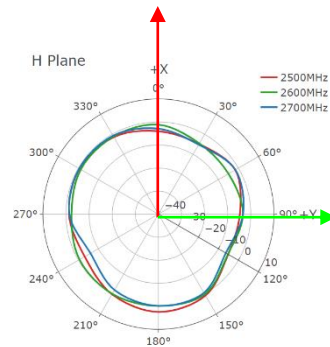
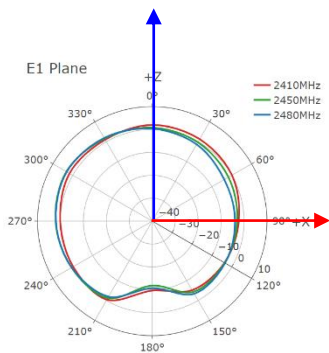
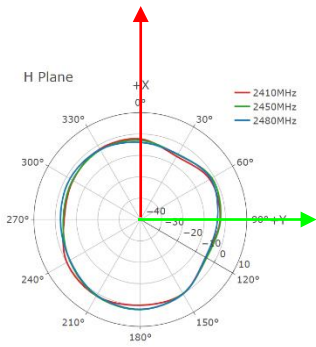
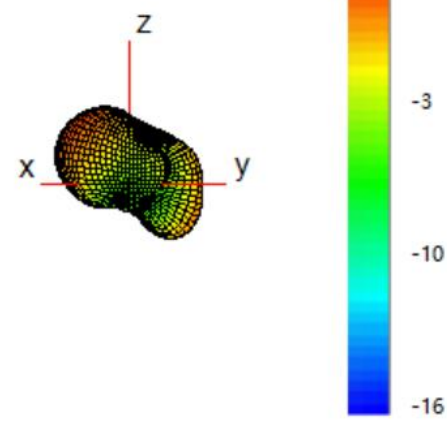

● **LMH1**

3600 MHz

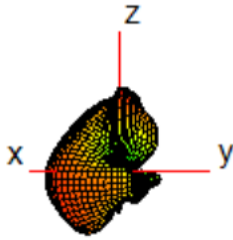

4000 MHz

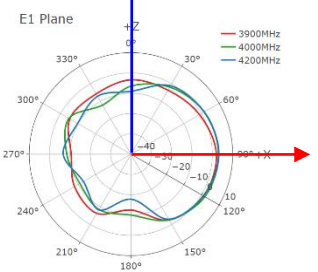
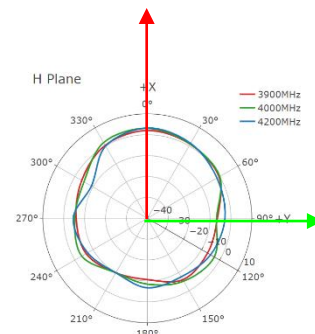
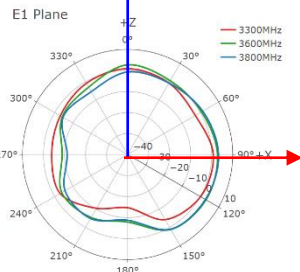
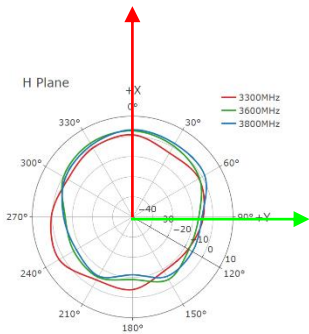
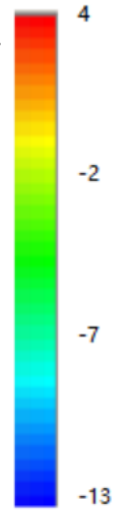
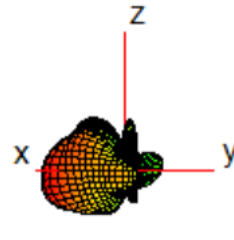

4700 MHz

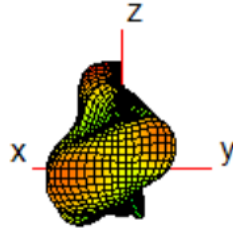

5500 MHz

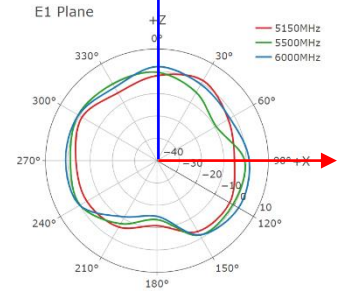
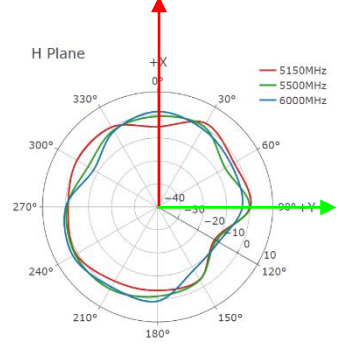
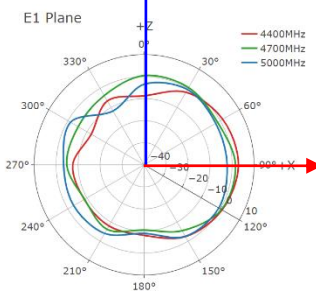
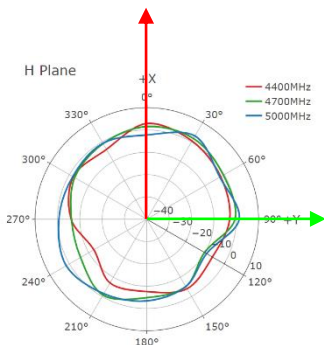
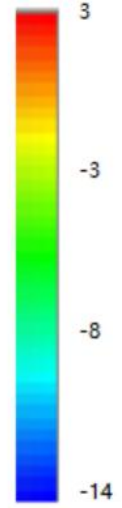
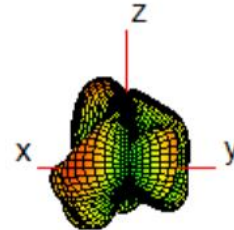

● LMH2

630 MHz

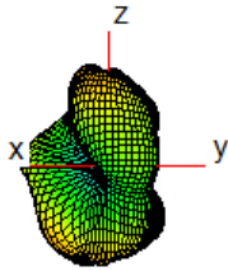

710 MHz

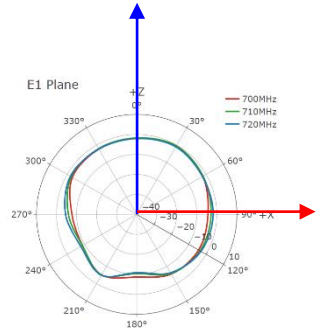
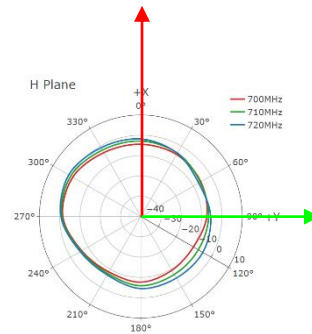
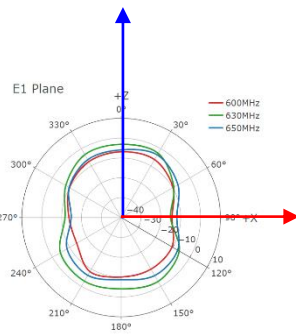
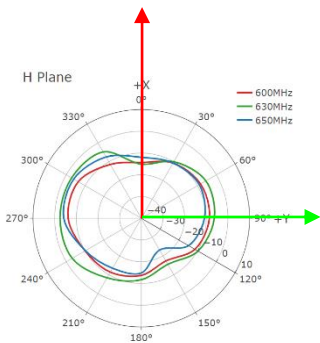
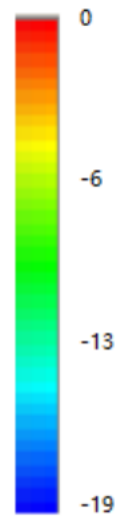
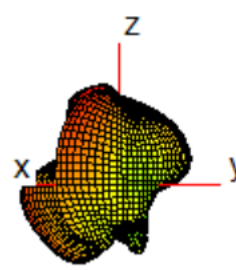

830MHz

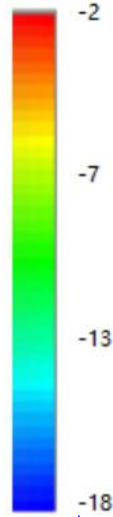
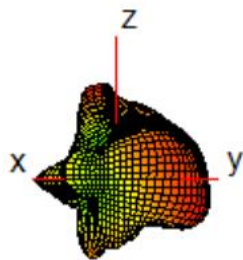

900MHz

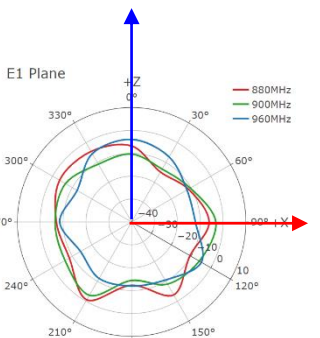
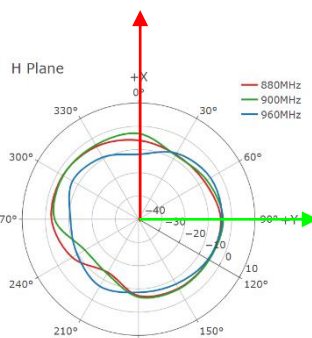
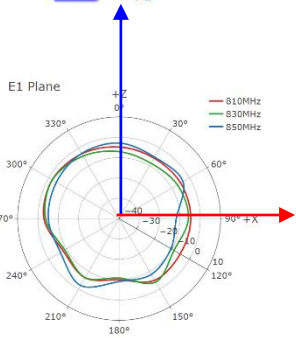
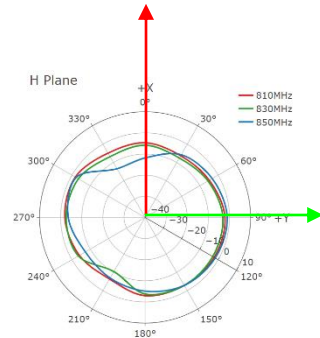
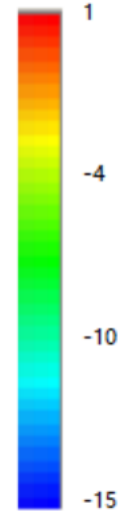
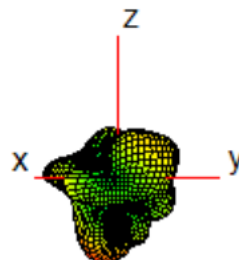

LMH2

1440 MHz

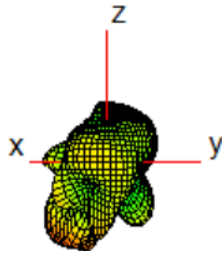

1740 MHz

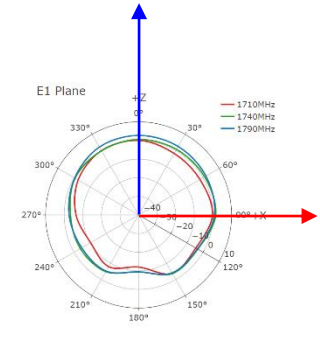
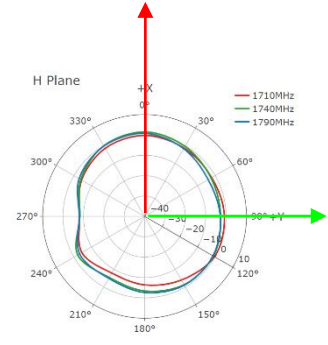
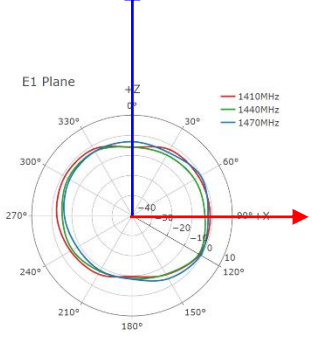
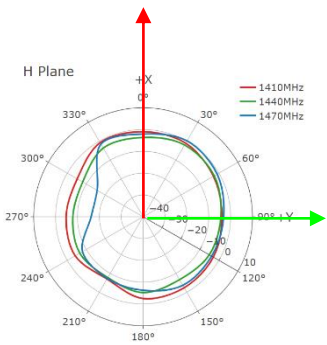
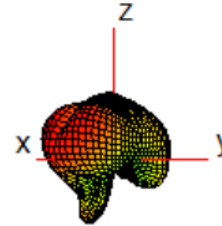

1880 MHz

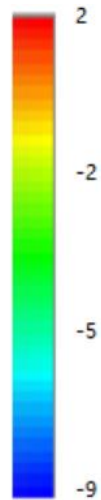
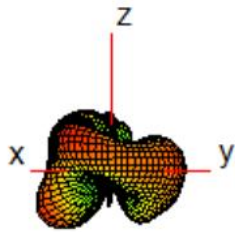

1950 MHz

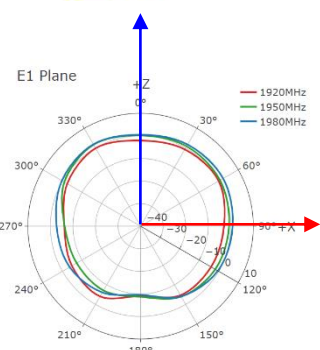
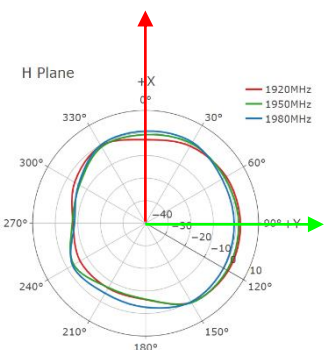
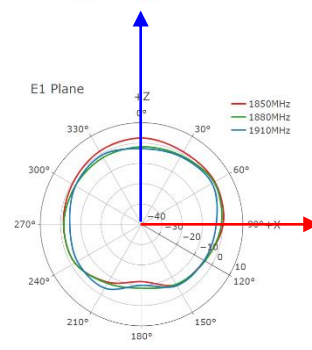
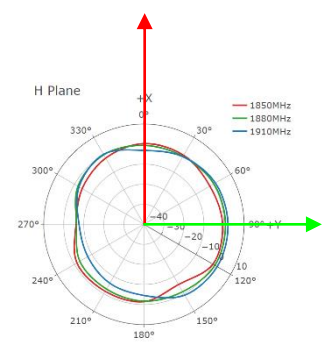
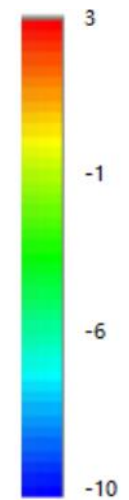
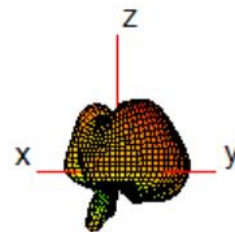

● **LMH2**

2140 MHz

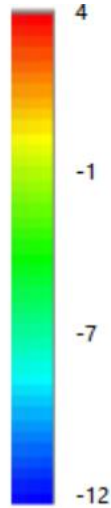
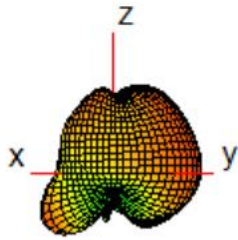

2350 MHz

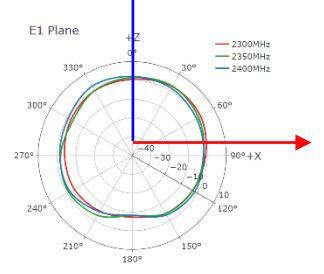
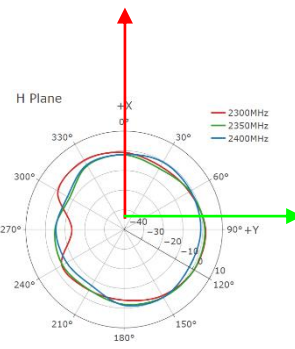
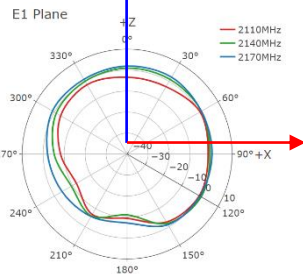
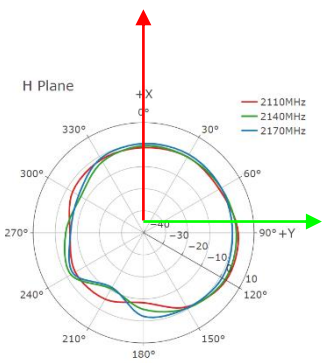
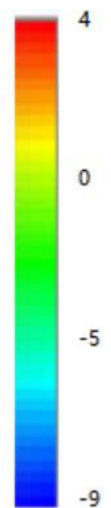
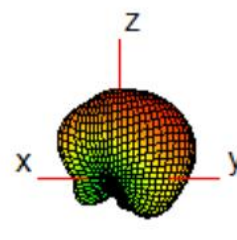

2450 MHz

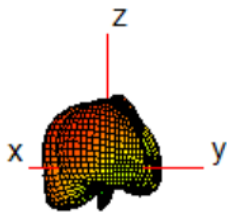

2600 MHz

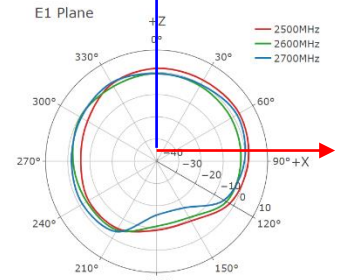
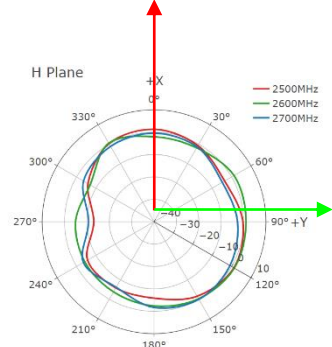
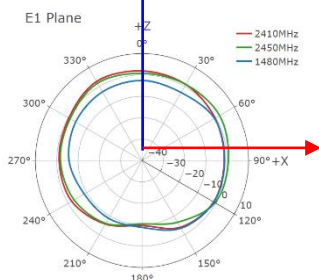
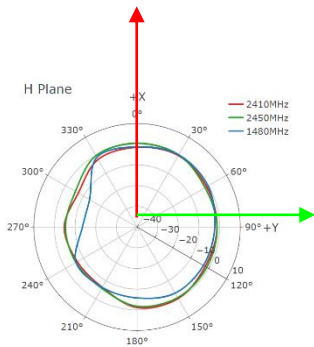
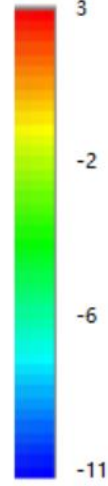
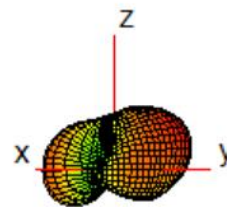

● **LMH2**

3600 MHz

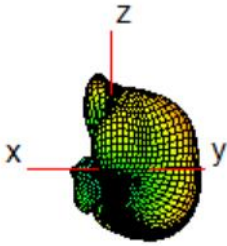

4000 MHz

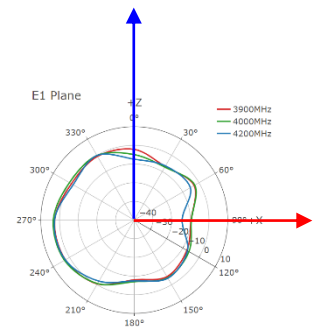
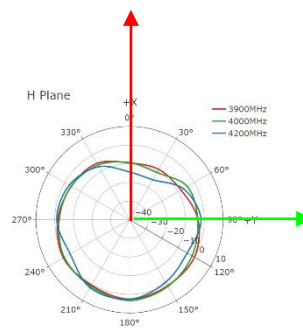
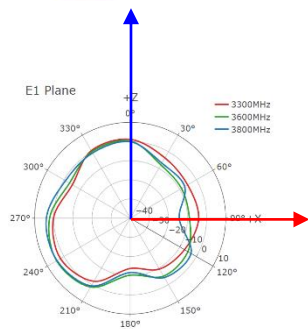
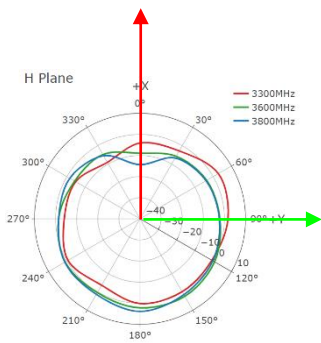
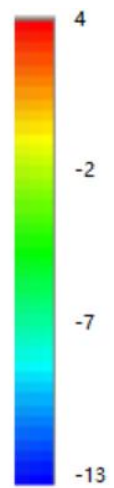
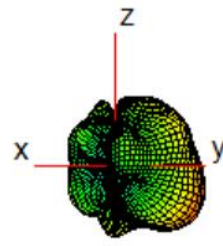

4700 MHz

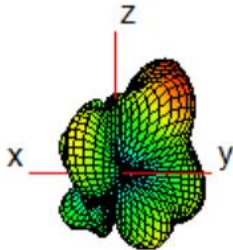

5500 MHz

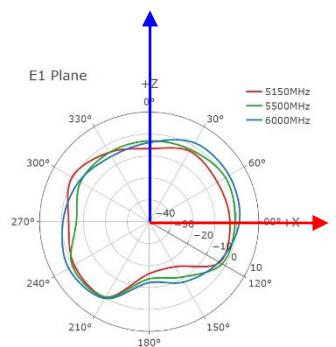
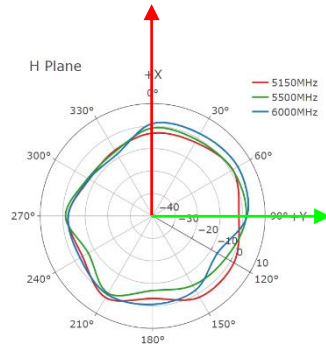
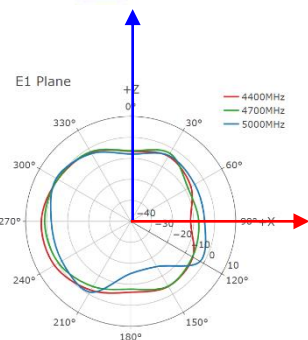
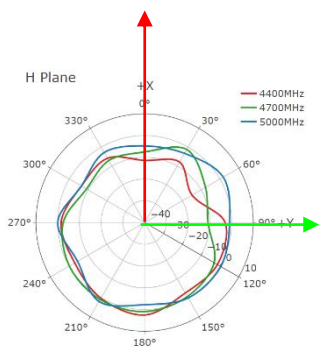
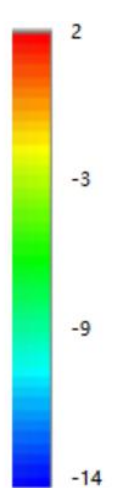
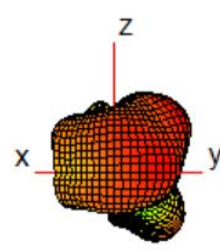

● **GNSS**

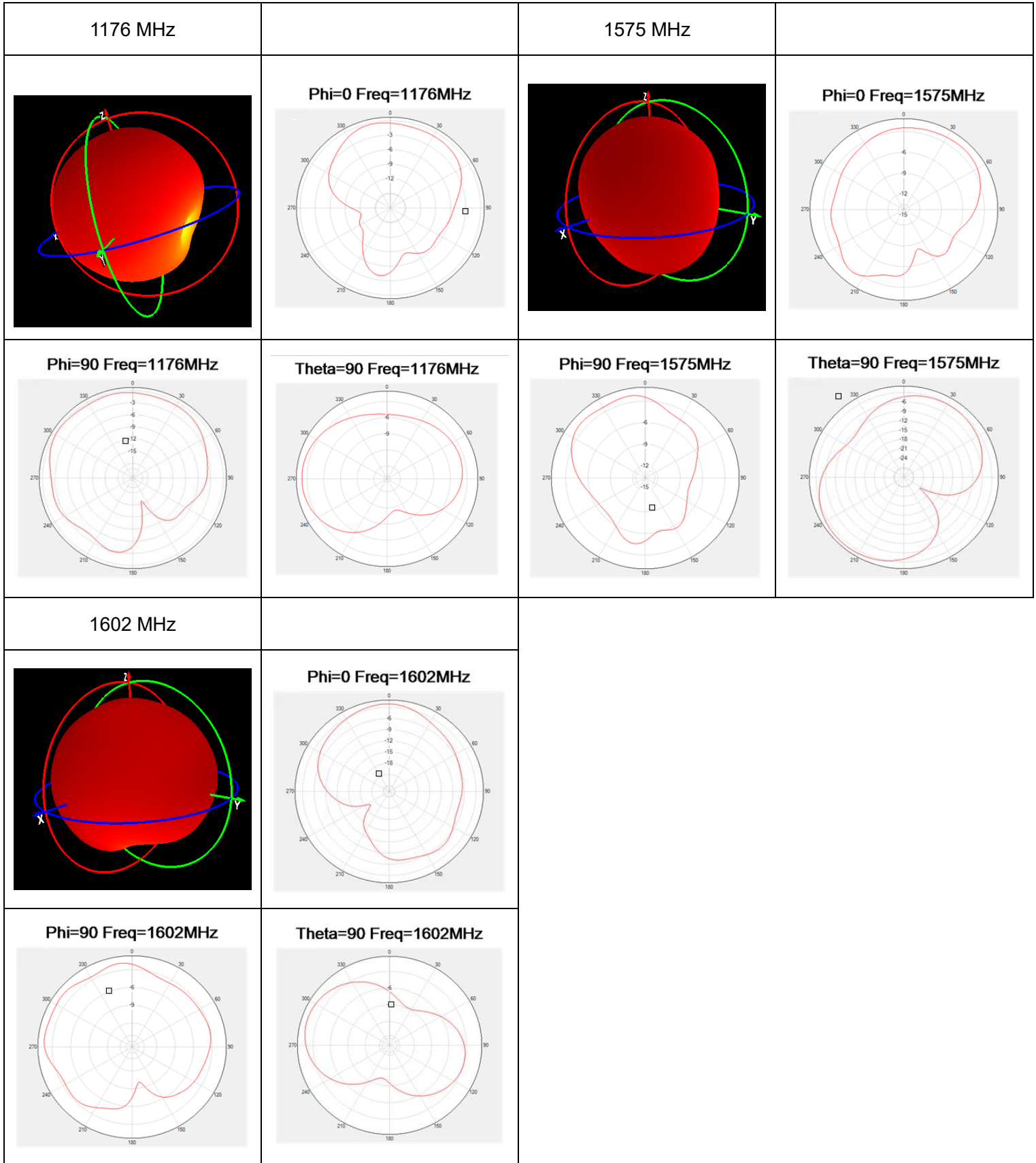

3.2.4.2 Test Status: On 320 mm × 240 mm Metal Plane

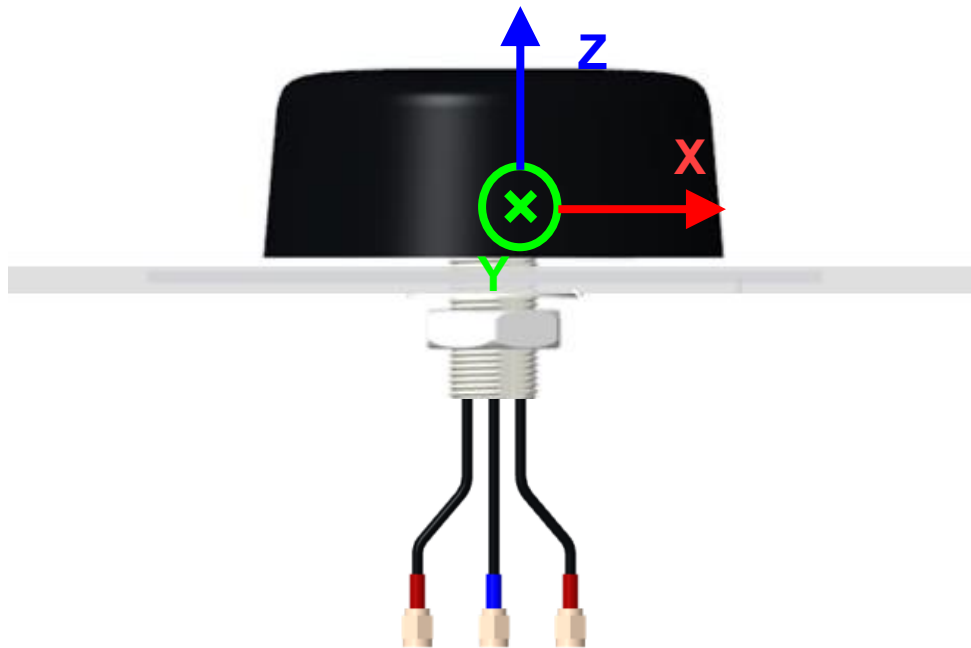

● **LMH1**

630 MHz

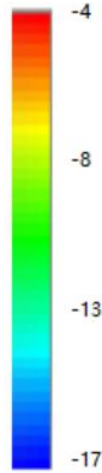
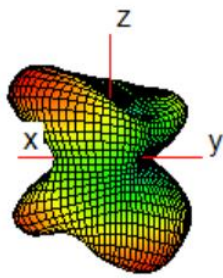

710 MHz

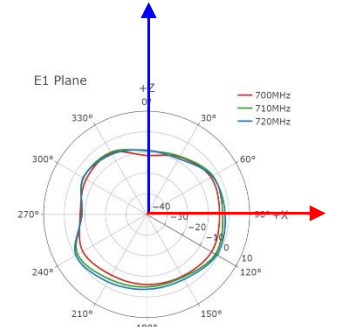
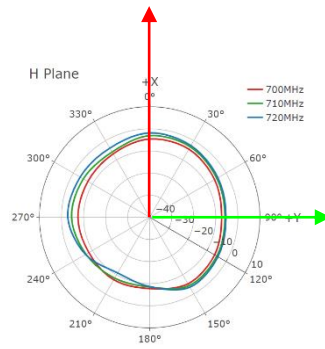
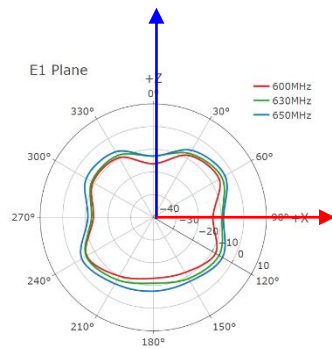
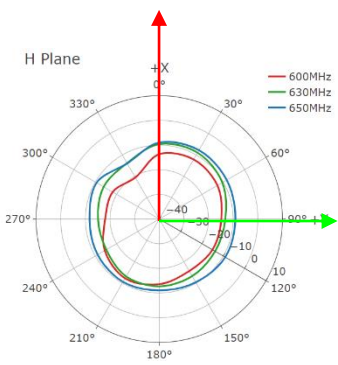
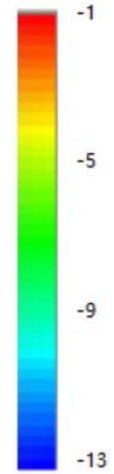
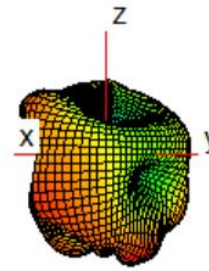

830 MHz

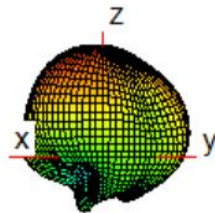

900 MHz

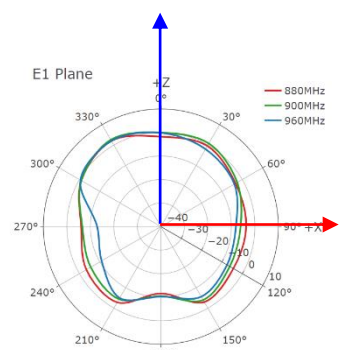
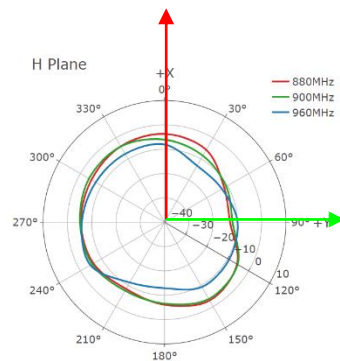
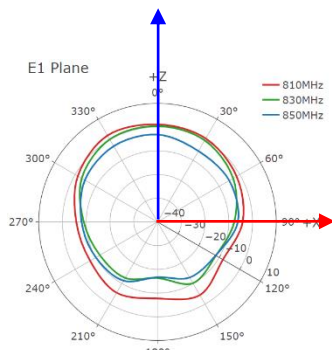
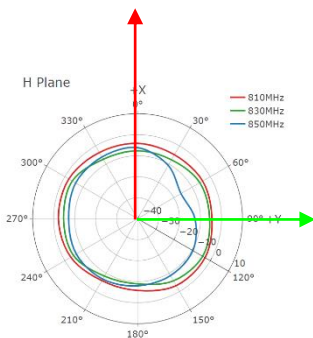
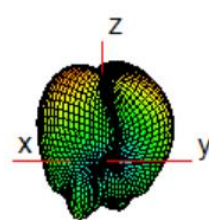

● **LMH1**

1440 MHz

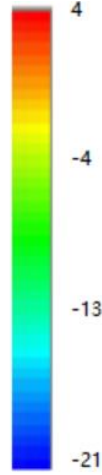
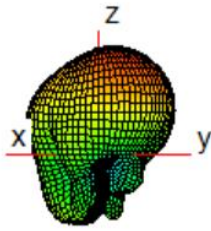

1740 MHz

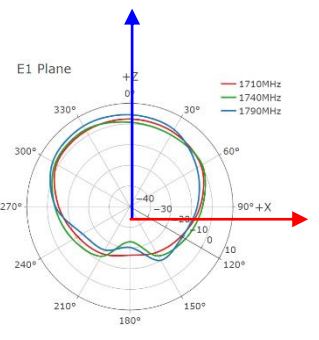
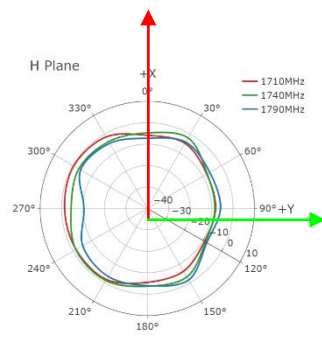
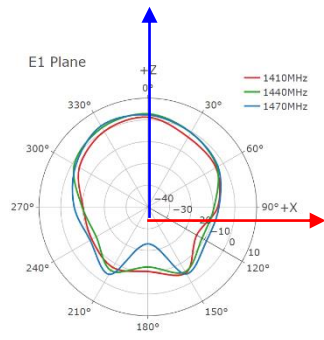
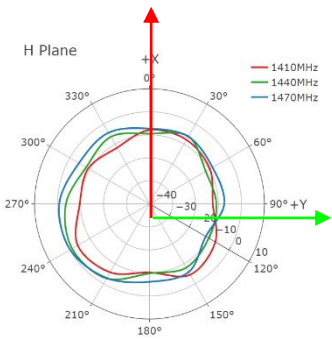
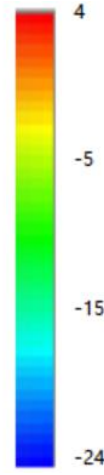
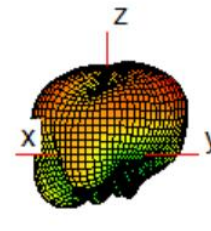

1880 MHz

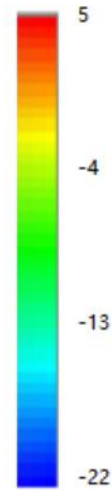
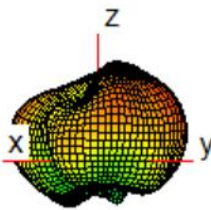

1950 MHz

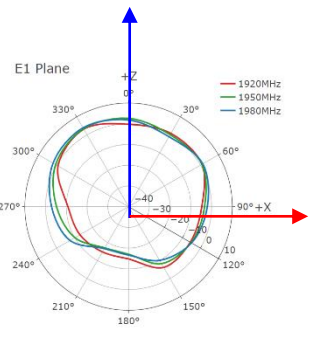
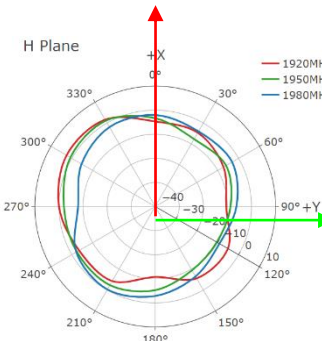
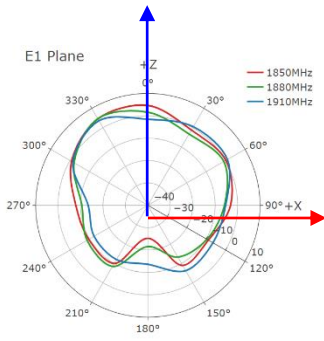
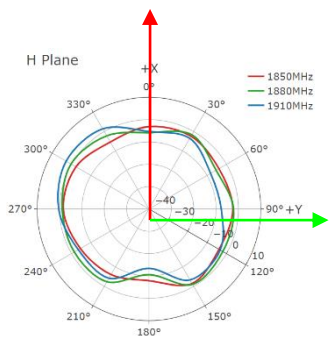
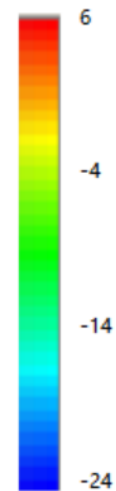
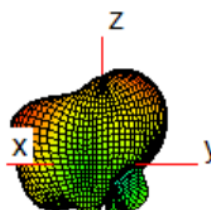

● LMH1

2140 MHz

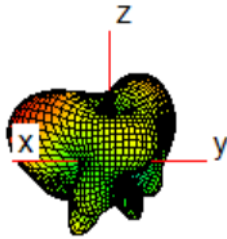

2350 MHz

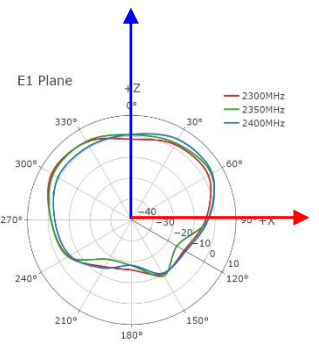
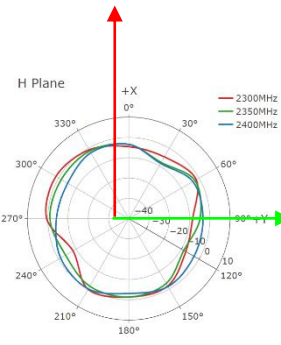
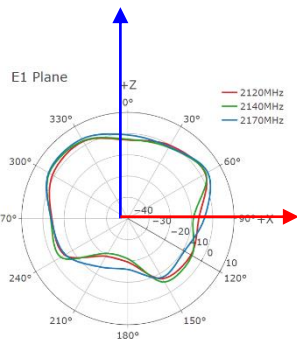
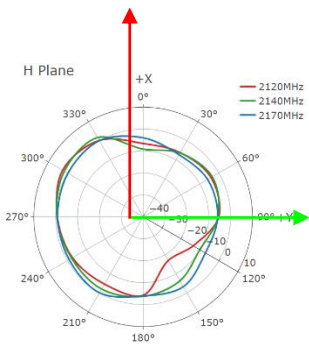
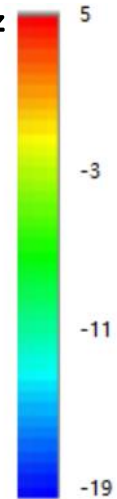
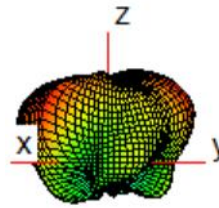

2450 MHz

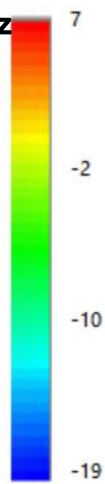
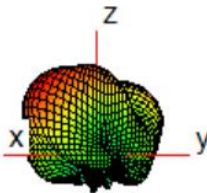

2600 MHz

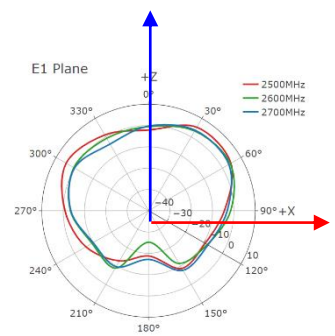
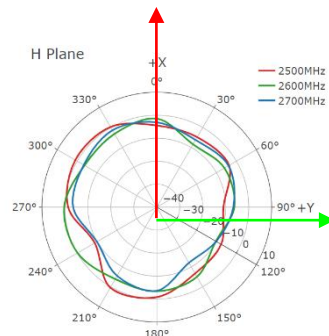
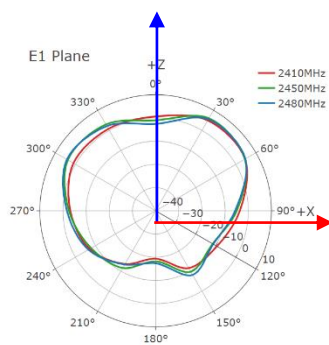
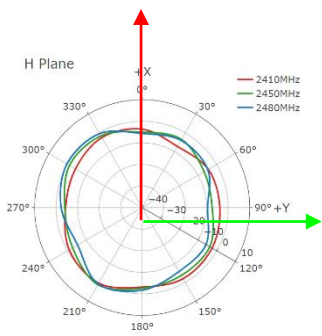
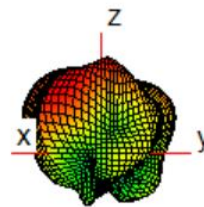

LMH1

3600 MHz

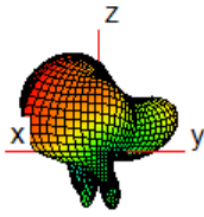

4000 MHz

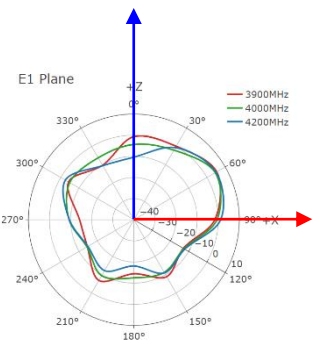
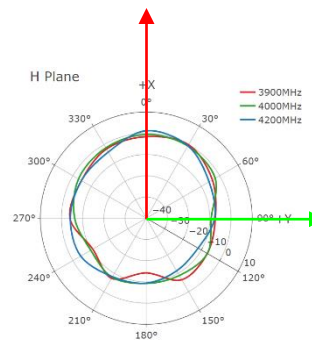
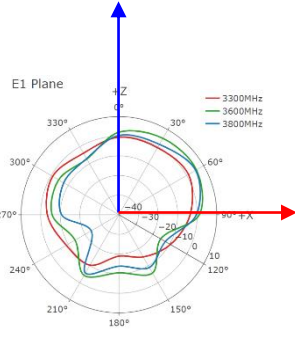
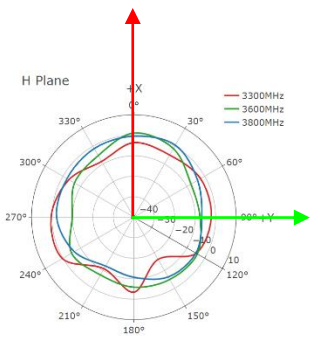
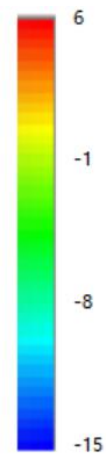
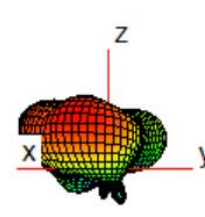

4700 MHz

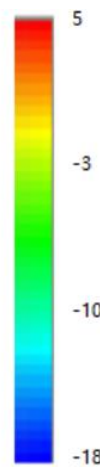
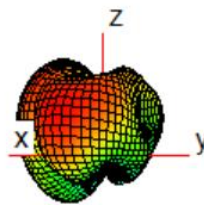

5500 MHz

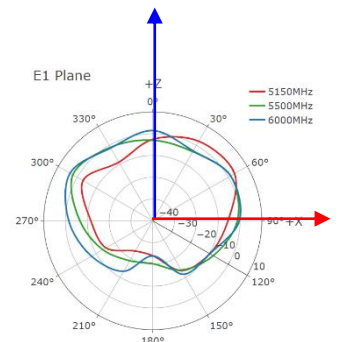
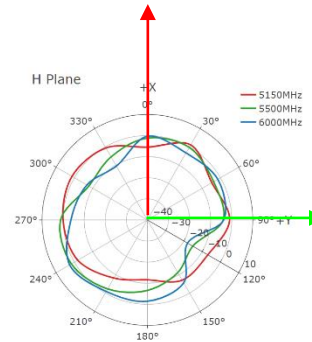
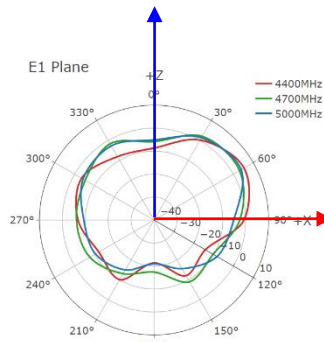
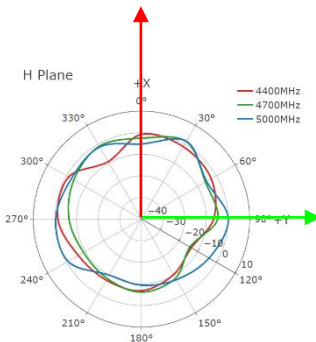
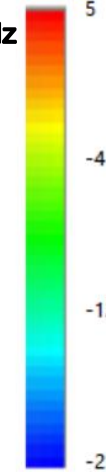
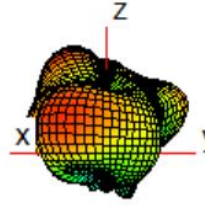

LMH2

630 MHz

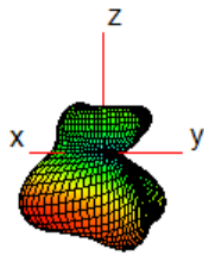

710 MHz

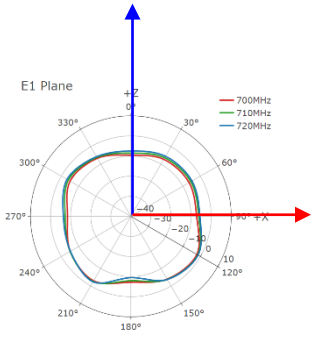
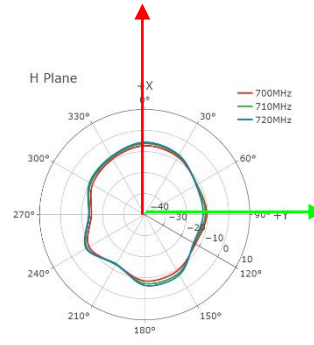
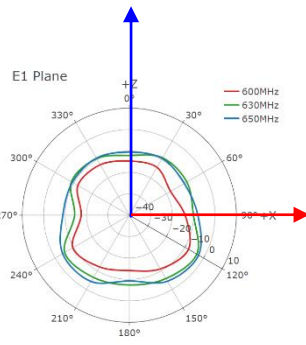
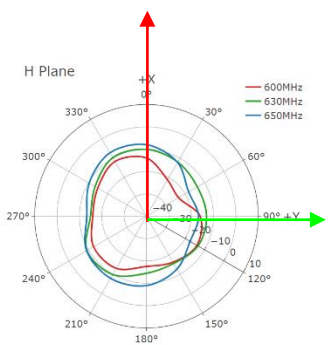
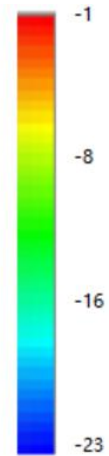
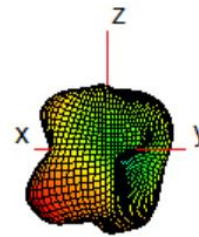

830 MHz

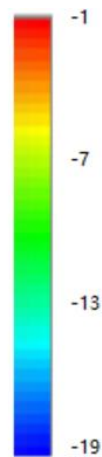
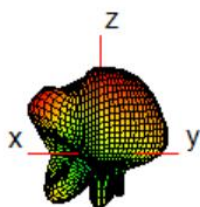

900 MHz

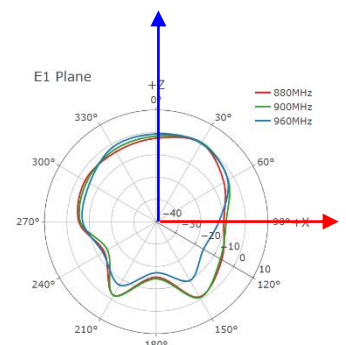
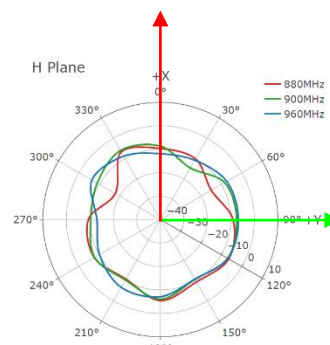
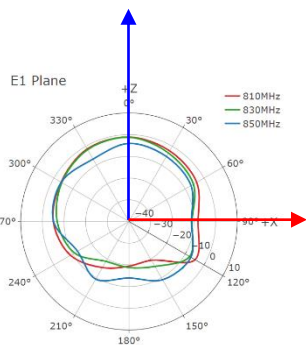
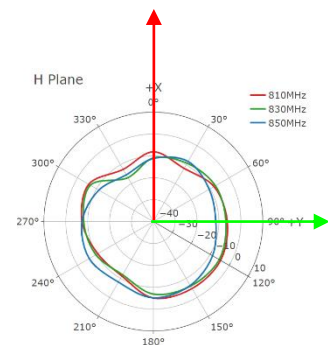
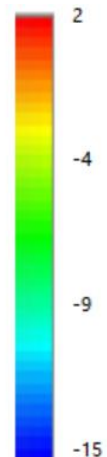
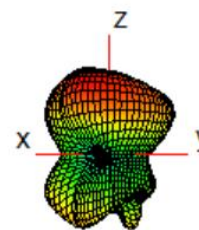

LMH2

1440 MHz

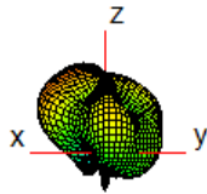

1740 MHz

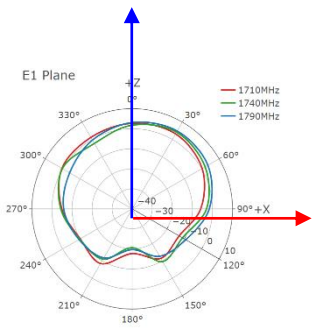
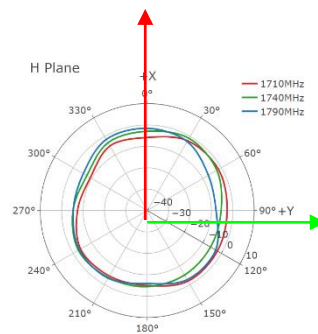
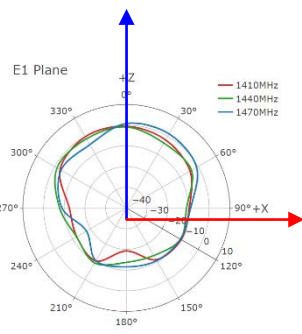
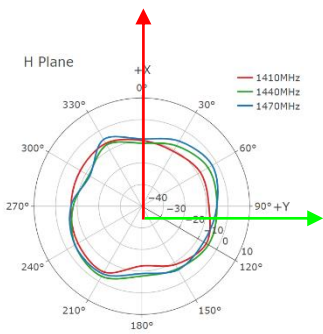
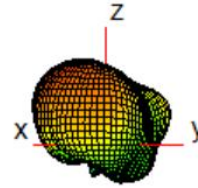

1880 MHz

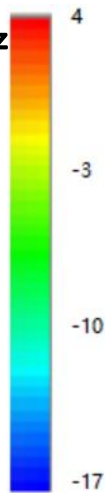
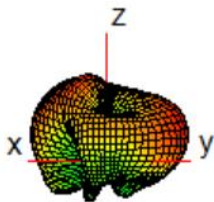

1950 MHz

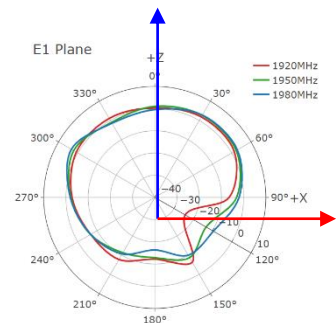
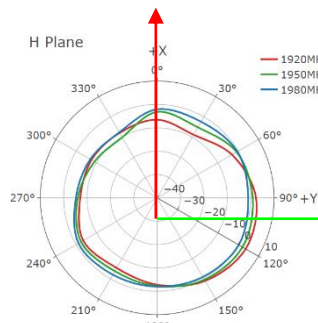
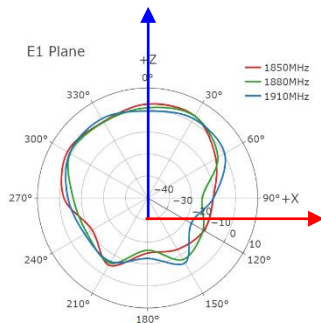
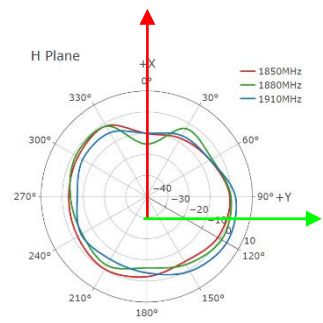
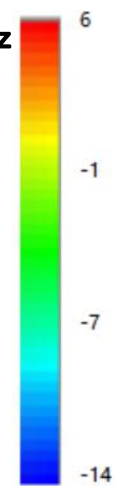
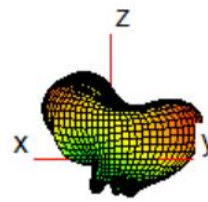

● **LMH2**

2140 MHz

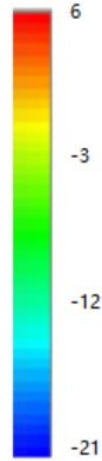
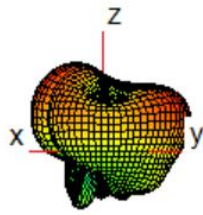

2350 MHz

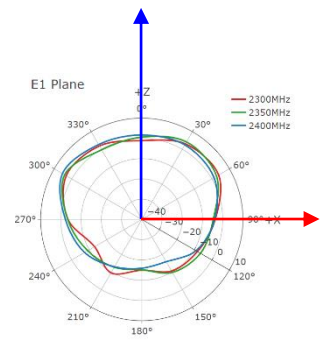
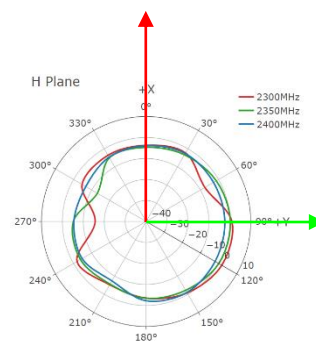
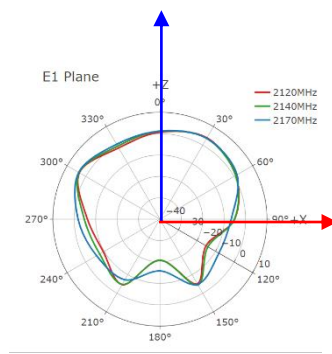
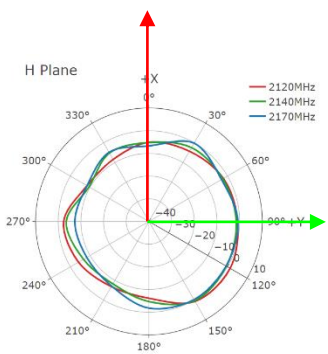
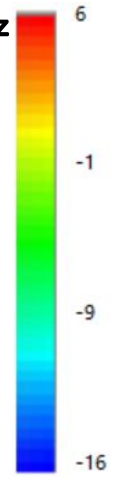
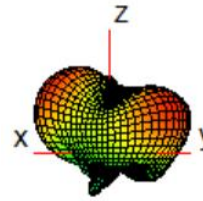

2460 MHz

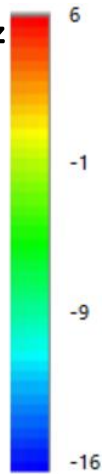
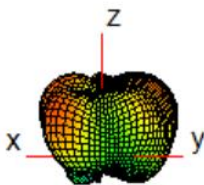

2600 MHz

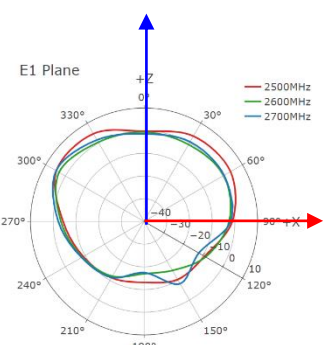
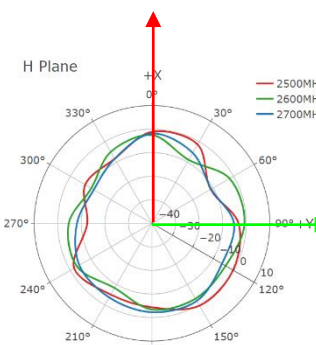
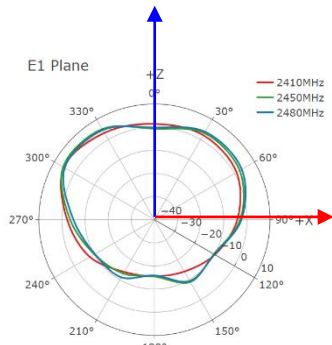
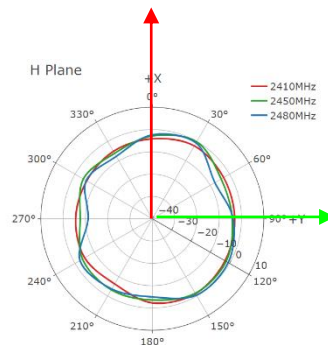
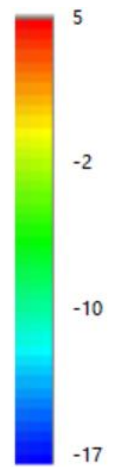
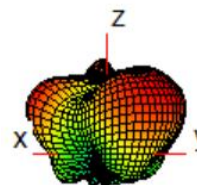

● **LMH2**

3600 MHz

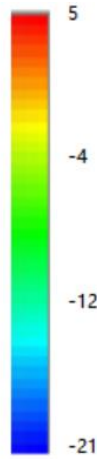
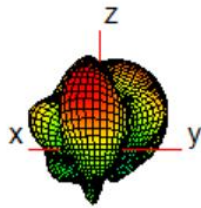

4000 MHz

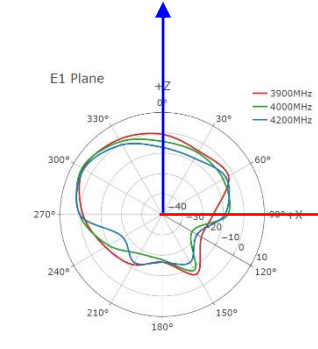
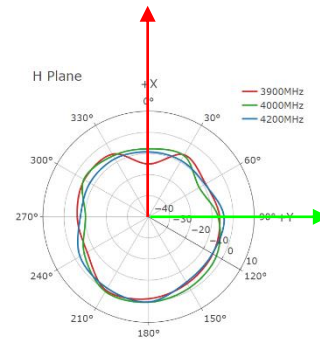
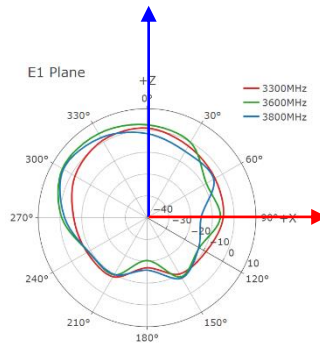
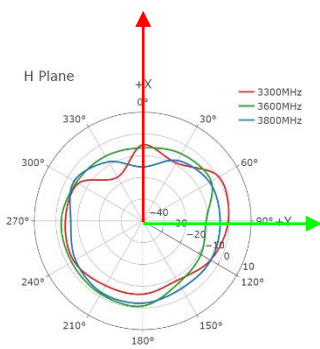
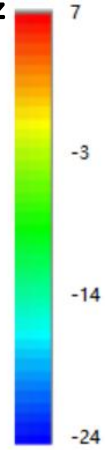
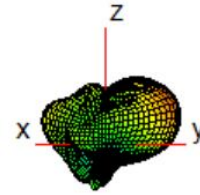

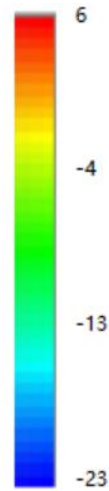
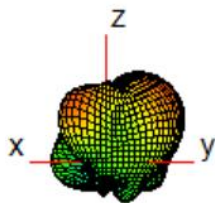

4700 MHz

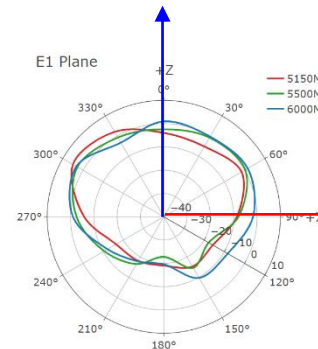
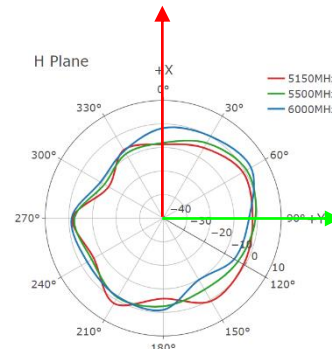
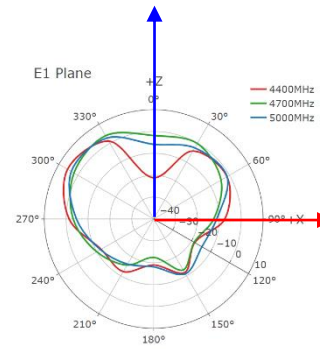
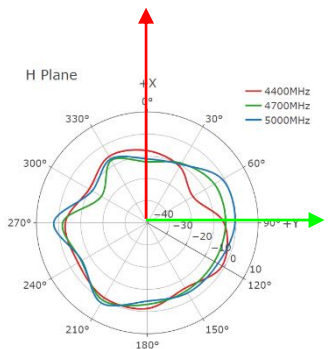
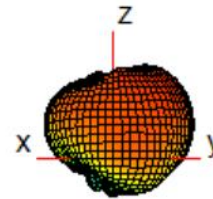

5500 MHz



4 Packaging

Step	Packaging Picture / 2D Picture	Description
1		<p>Wrape the product with a PE bag and put into the inner box.</p>
2		<p>Put the EPE sheet on the top of the product.</p>
3		<p>Inner box diagram</p> <p><u>Inner Box Size:</u> <u>L x W x H = 165 x 165 x 135 mm</u></p>

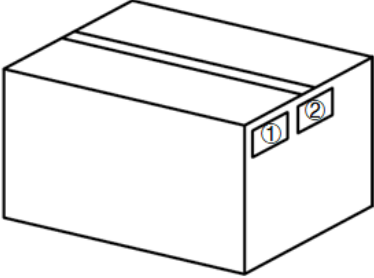
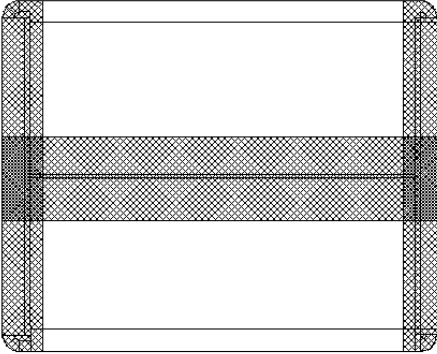
<p>4</p>		<p>(18 Inner Boxes / Carton Box) (18 Antennas / Carton Box) Estimated quantity Products that cannot fill the entire carton box are packed in a suitable size carton box. <u>Carton Size:</u> <u>L × W × H = 525 × 525 × 305 mm</u></p>
<p>5</p>		<p>Position for Attaching Labels ① Carton Label ② Quality Label</p>
<p>6</p>		<p>Sealing Cartons H-shaped sealing cartons</p>

5 Installation

- LMHs and MHs can be connected arbitrarily.
- Recommended hole dimensions as below.
- Recommended mounting plate thickness: 2–10 mm.
- Recommended mounting plate size: $\geq \Phi 85$ mm.

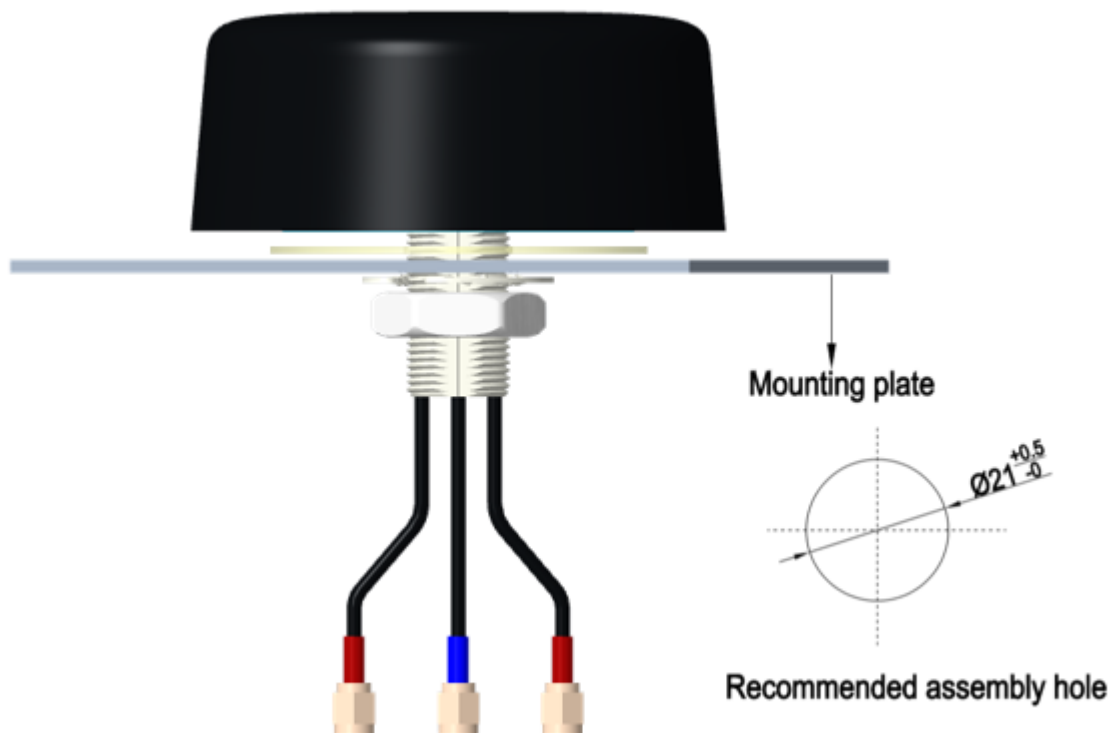

			Installation Instructions		
Tube Mark	Tube Color	Cable	Connector	Frequency (MHz)	Technology
LMH	Red	RG405	SMA Male	600–960 MHz, 1400–6000 MHz	5G/4G/3G/2G
GNSS	Blue	RG174	SMA Male	1164–1189 MHz, 1565–1606 MHz	GPS/GLONASS/GALILEO/ BDS/QZSS/IRNSS

- Note: YEMN301J1AH (3IN1=2 × LMH +1 × GNSS)

6 Appendix Reference

Abbreviation	Description
5G	5th-Generation Mobile Communication Technology
4G	4th-Generation Mobile Communication Technology
3G	3rd-Generation Mobile Communication Technology
2G	2nd-Generation Mobile Communication Technology
GNSS	Global Navigation Satellite System
GLONASS	Global Navigation Satellite System (Russia)
GPS	Global Positioning System
QZSS	Quasi-Zenith Satellite System
IRNSS	Indian Regional Navigation Satellite System
LTE	Long Term Evolution
LTE-A	LTE-Advanced
NB-IoT	Narrow Band Internet of Things
LPWA	Low Power Wide Area
WCDMA	Wideband Code Division Multiple Access
GSM	Global System for Mobile Communications
Wi-Fi	Wireless Fidelity
GND	Ground
LMH	Low-Middle-High Bands
LMHs	LMH antennas
MH	Middle-High Envelope Bands
MHs	MH antennas

FS	In Free Space
MP	On Metal Plane
VSWR	Voltage Standing Wave Ratio
S-Parameter	Scatter Parameter
LNA	Low Noise Amplifier
GPRS	General Packet Radio Service
WLAN	Wireless Local Area Network
HSPA	High-Speed Packet Access
RHCP	Right Hand Circularly Polarized
RoHS	Restriction of Hazardous Substances
REACH	Registration, Evaluation, Authorisation and Restriction of Chemicals
IP	Ingress Protection
IK	Impact Protection
ECE R118	UN Regulation No. 118 (ECE R118-approved cables are flame-resistant cables)

Contact Us

At Quectel, our aim is to provide timely and comprehensive services to our customers. If you require any assistance, please contact our headquarters:

Quectel Wireless Solutions Co., Ltd.

No. 8 Waipojing Road, Sijing Town, Songjiang District, Shanghai 201601, China

Tel: +86 21 5108 6236

Email: info@quectel.com

Or our local offices. For more information, please visit:

<https://www.quectel.com/contact/>.

For technical support, or to report documentation errors, please visit:

<https://www.quectel.com/tech-support/>.

Or email us at: support@quectel.com.

Legal Notices

We provide this document to support your product design. You are required to design your products based on the specifications and parameters set forth herein. You agree that you are responsible for using independent analysis and evaluation in designing intended products, and we provide reference designs for illustrative purposes only. Before using any hardware, software or service guided by this document, please read this notice carefully. Even though we employ commercially reasonable efforts to provide the best possible experience, you hereby acknowledge and agree that this document and related services hereunder are provided to you on an “as available” basis. You acknowledge and agree that we may add to, amend, or restate this document at any time at our sole discretion without any prior notice to you, and such additions, amendments, or restatements shall be binding upon you.

Use and Disclosure Restrictions

License Agreements

The recipient of any hardware, software, materials, or documentation provided by us shall keep such content confidential, unless expressly authorized by us. The recipient shall not disclose, access, or use any part of the received content for any purpose other than the execution and implementation of the intended project.

Copyright

Our and third-party products hereunder may contain copyrighted materials, including but not limited to protected content, hardware, software, and documentation owned by us or applicable third parties. Unless prior written consent is obtained, you shall not access, use, or disclose any documents or information provided by us, nor shall you copy, reproduce, republish, display, translate, distribute, merge, modify, or create derivative works from any such copyrighted materials. We and the applicable third party retain exclusive rights to all copyrighted materials. No license to any patents, copyrights, trademarks, or service marks shall be granted or transferred. For the avoidance of doubt, no form of purchase shall be construed as granting any license beyond a normal, non-exclusive, royalty-free license to use the product. We reserve the right to pursue legal action against any violation of confidentiality obligations, unauthorized use, or any other unlawful or malicious use of the aforementioned documents and information.

Trademarks

Unless otherwise expressly provided, nothing in this document shall be construed as conferring any rights to use any trademark, trade name, name, abbreviation, or counterfeit thereof owned by us or any third party in advertising, publicity, or any other contexts.

Third-Party Rights

You understand that this document may refer to hardware, software, and/or documentation owned by one or more third parties (“third-party materials”). Use of such third-party materials is subject to all applicable restrictions and obligations set forth herein.

We make no warranty or representation, either express or implied, regarding the third-party materials, including but not limited to any implied or statutory, warranties of merchantability or fitness for a particular purpose, quiet enjoyment, system integration, information accuracy, and non-infringement of any third-party intellectual property rights with regard to the licensed technology or use thereof. Nothing herein constitutes a representation or warranty by us to either develop, enhance, modify, distribute, market, sell, offer for sale, or otherwise maintain production of any our products or any other hardware, software, device, tool, information, or product. We moreover disclaim any and all warranties arising from the course of dealing, course of performance, or usage of trade.

Privacy Policy

To enable product functionality, certain device data may be uploaded to our or third-party servers, including those operated by carriers, chipset suppliers, or servers designated by you. We strictly comply with applicable laws and regulations and will retain, use, disclose, or otherwise process relevant data solely for the purpose of enabling product functionality, or as permitted by applicable laws. Before interacting with any third party regarding data exchange, please be informed of and understand their privacy and data security policies.

Disclaimer

- a) We shall not be liable for any damages resulting from failure to comply with applicable operational or design specifications.
- b) We shall bear no liability for any inaccuracies or omissions in this document, nor for any damages arising from the use of the information contained herein.
- c) While we make every effort to ensure the integrity, accuracy, and timeliness of the features and functions under development, errors or omissions may nevertheless occur. Unless otherwise provided in a valid written agreement, we make no warranties of any kind, express, implied, or statutory, and disclaim all liability for any loss or damage arising from the use of any features or functions under development, to the maximum extent permitted by law, regardless of whether such loss or damage is foreseeable.
- d) We assume no legal responsibility for the accessibility, safety, accuracy, availability, legality, or completeness of any information, content, advertising, commercial offers, products, services, or materials on third-party websites or third-party resources.

Copyright © Quectel Wireless Solutions Co., Ltd. 2026. All rights reserved.

Revision History

Version	Date	Author	Note
-	2024-09-27	Mordecai Liu/ Junsen Li/ Lance Sun/ David Liu/ Rainey Liao	Creation of the document
1.0	2024-09-27	Mordecai Liu/ Junsen Li/ Lance Sun/ David Liu/ Rainey Liao	First official release
1.1	2026-01-26	Strong Qiang	Updated the packaging (Chapter 4).

QUECTEL

www.quectel.com