



Antenna Datasheet

Product OC: YEBT002W7AM

Version: 1.1

Date: 2026-01-26

Status: Released

Product Name: Wi-Fi Terminal Mount Fiberglass Dipole External Antenna

Key Features:

Frequency Band: 2400–2500 MHz

Dimensions: Φ 25.5 mm \times 300 mm

Efficiency: Up to 74 %

RoHS and REACH Compliant

IP Rating: IP67

Overview

The YEBT002W7AM is a Wi-Fi fiberglass antenna measuring Φ 25.5 mm \times 300 mm. This ultra-wide-band WIFI antenna provides broad coverage from 2400–2500 MHz. The antenna is terminated with N type Male connectors. This low profile, terminal mount omni-directional antenna, ideal for applications where the antenna is required to be discrete, is easy to install with maximum durability assured thanks to its IP67 rated FRP enclosure. It is compatible with Quectel's Wi-Fi Series modules.

The antenna is designed as dipole type to work with various GND plane sizes or in free space. It is a perfect antenna product for customers that desire highest performance. This omni-directional antenna is ideally suited for microwave communication equipment, communication base station, radio and television system, weather radar, offering great performance with its high gain and efficiency.

- **Typical applications include:**
 - ✓ Microwave Communication Equipment
 - ✓ Communication Base Station
 - ✓ Radio and Television System
 - ✓ Weather Radar

Quectel provides comprehensive antenna design support such as simulation, testing and manufacturing for custom antenna solutions to meet your specific application needs. We have regional R & D centers to offer quick response to meet your requirements. Please contact our sales & FAEs if you have any requests.

Contents

Overview	1
Contents	2
1 Specification	3
1.1. Electrical.....	3
1.2. Mechanical & Environmental	4
2 Drawing	5
3 Detailed Performance	6
3.1. S-Parameter Test	6
3.1.1. VSWR	6
3.1.2. Return Loss.....	7
3.2. Radiation Performance Test.....	8
3.2.1. Efficiency.....	8
3.2.2. Average Gain	9
3.2.3. Peak Gain	10
3.2.4. 3D & 2D Radiation Pattern	11
4 Packaging	13
Contact Us	15
Legal Notices	16
Revision History	18

1 Specification

Test Condition: Free Space

1.1. Electrical

Electrical	
Frequency Range	2400–2500 MHz
Impedance	50 Ω
Polarization	Linear
Radiation Pattern	Omni-directional

Specification	Band	Band	Wi-Fi 2G	Wi-Fi 5G	Wi-Fi 6G
		Freq. (MHz)	2400–2500	5150–5850	5925–7125
Max. VSWR			1.3	-	-
Max. Return Loss (dB)			-18.7	-	-
AVG Eff. (%)			73.7	-	-
AVG AVG Gain (dB)			-1.3	-	-
Max. Peak Gain (dBi)			4.3 (2410)	-	-
VSWR	≤ 1.3				
Return Loss	≤ -18.7 dB				
Peak Gain	≤ 4.3 dBi				

1.2. Mechanical & Environmental

Mechanical	
Antenna Dimensions	Φ 25.5 mm × 300 mm
Material & Color	FRP & White
Connector Type	N-MALE
Mounting Type	Terminal
Weight	Typ. 180 g
Environmental	
Operation Temperature	-40 °C to +85 °C
Storage Temperature	-40 °C to +85 °C
Ingress Protection (IP) Rating	IP67 (After Installation)
RoHS and REACH Compliant	Yes

2 Drawing

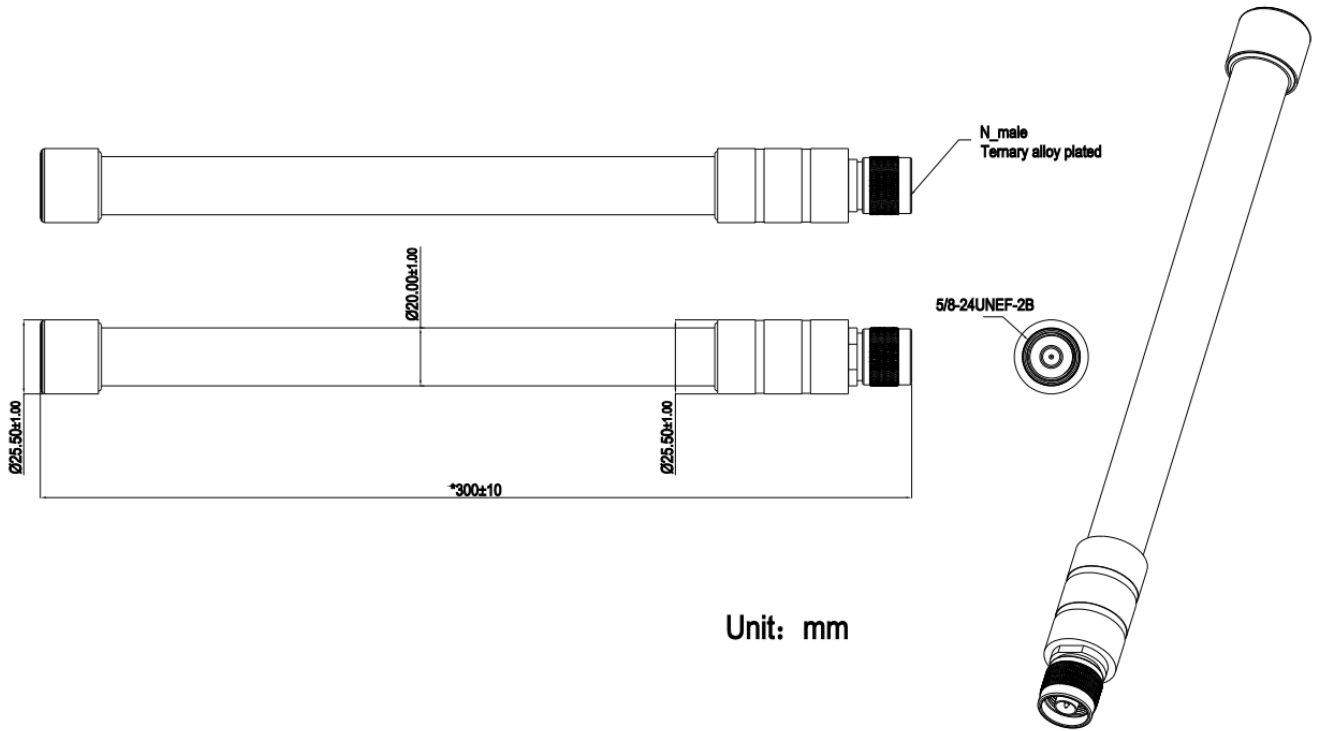

3 Detailed Performance

3.1. S-Parameter Test

3.1.1. VSWR

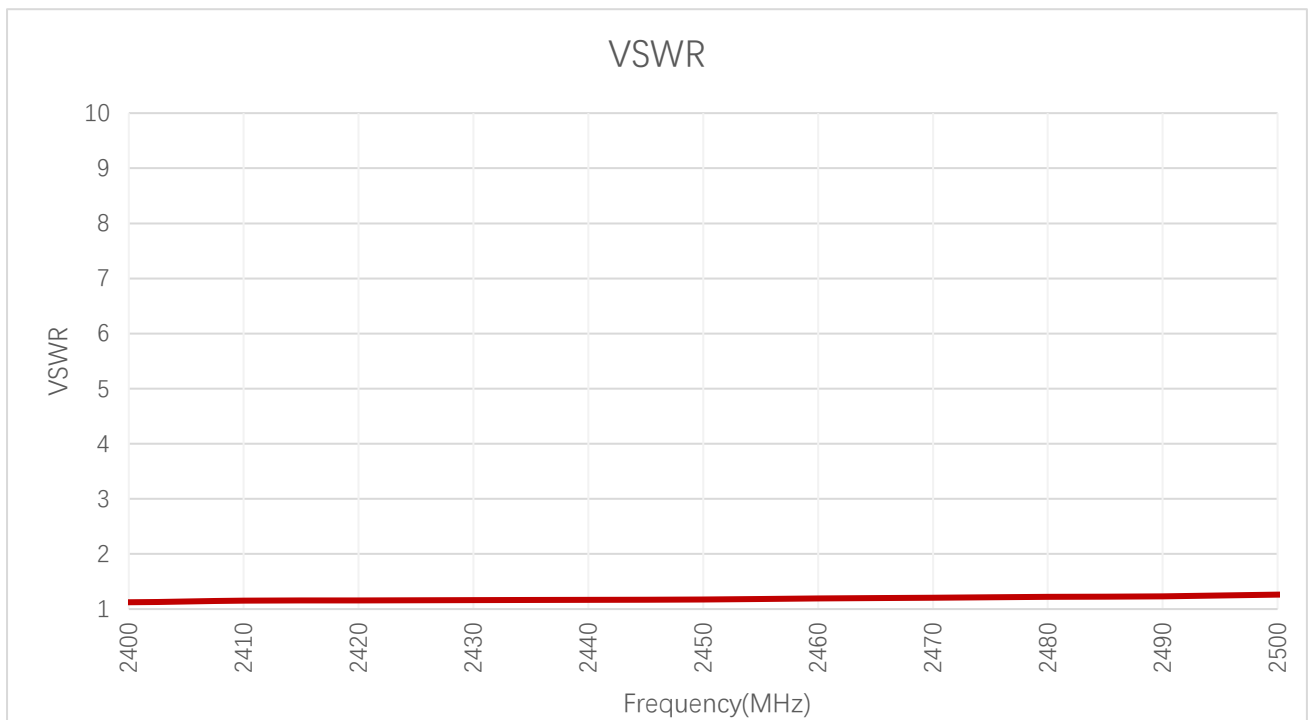

VSWR

Frequency (MHz)	2400	2450	2500	5150	5500	5850	5925	6525	7125
VSWR	1.1	1.2	1.3	-	-	-	-	-	-

3.1.2. Return Loss



Return Loss (dB)

Frequency (MHz)	2400	2450	2500	5150	5500	5850	5925	6525	7125
Return Loss (dB)	-24.7	-22.0	-18.7	-	-	-	-	-	-

3.2. Radiation Performance Test

3.2.1. Efficiency

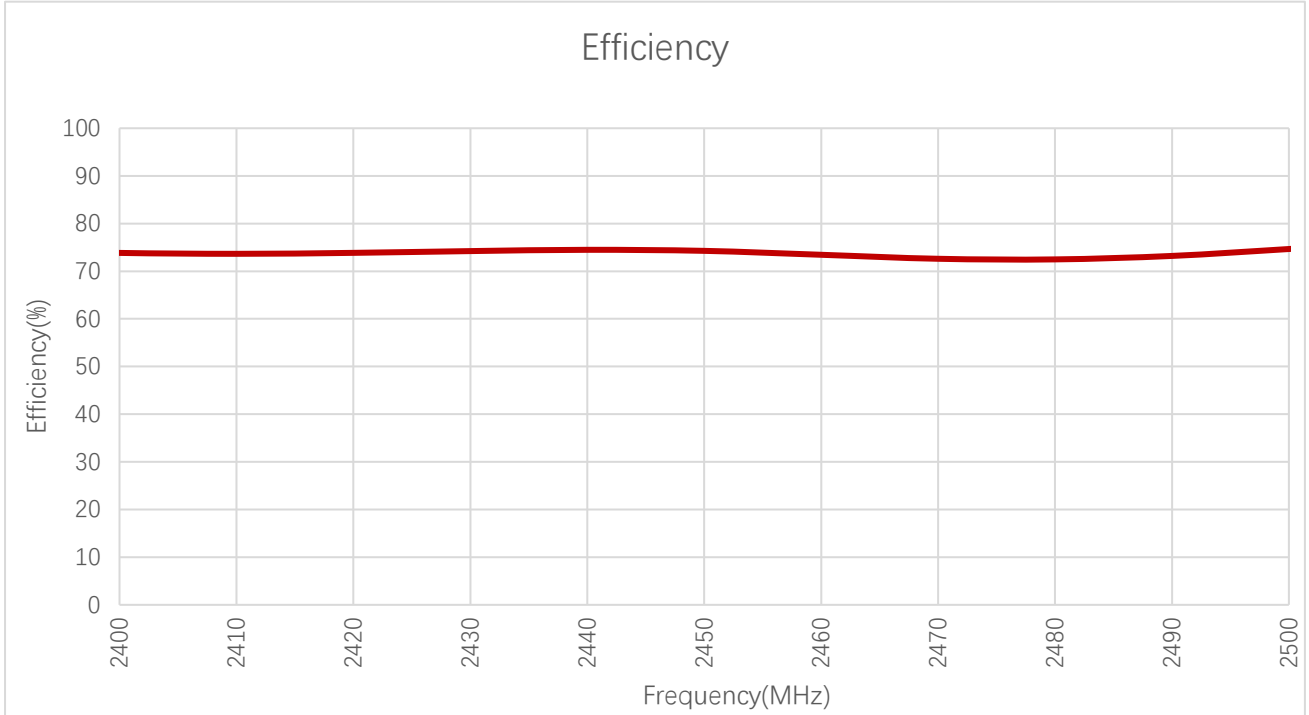

Efficiency (%)

Frequency (MHz)	2400	2450	2500	5150	5500	5850	5925	6525	7125
Efficiency (%)	73.8	74.3	74.7	-	-	-	-	-	-

3.2.2. Average Gain

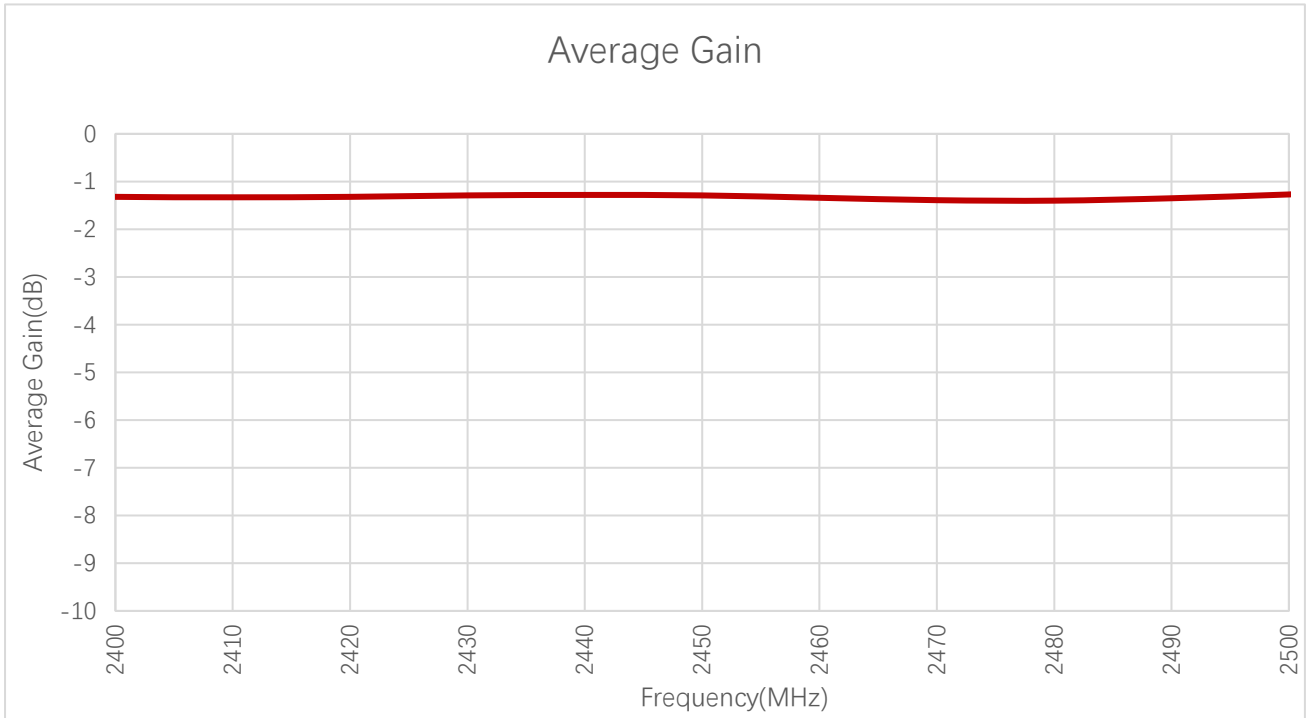

Average Gain (dB)

Frequency (MHz)	2400	2450	2500	5150	5500	5850	5925	6525	7125
Average Gain (dB)	-1.3	-1.3	-1.3	-	-	-	-	-	-

3.2.3. Peak Gain

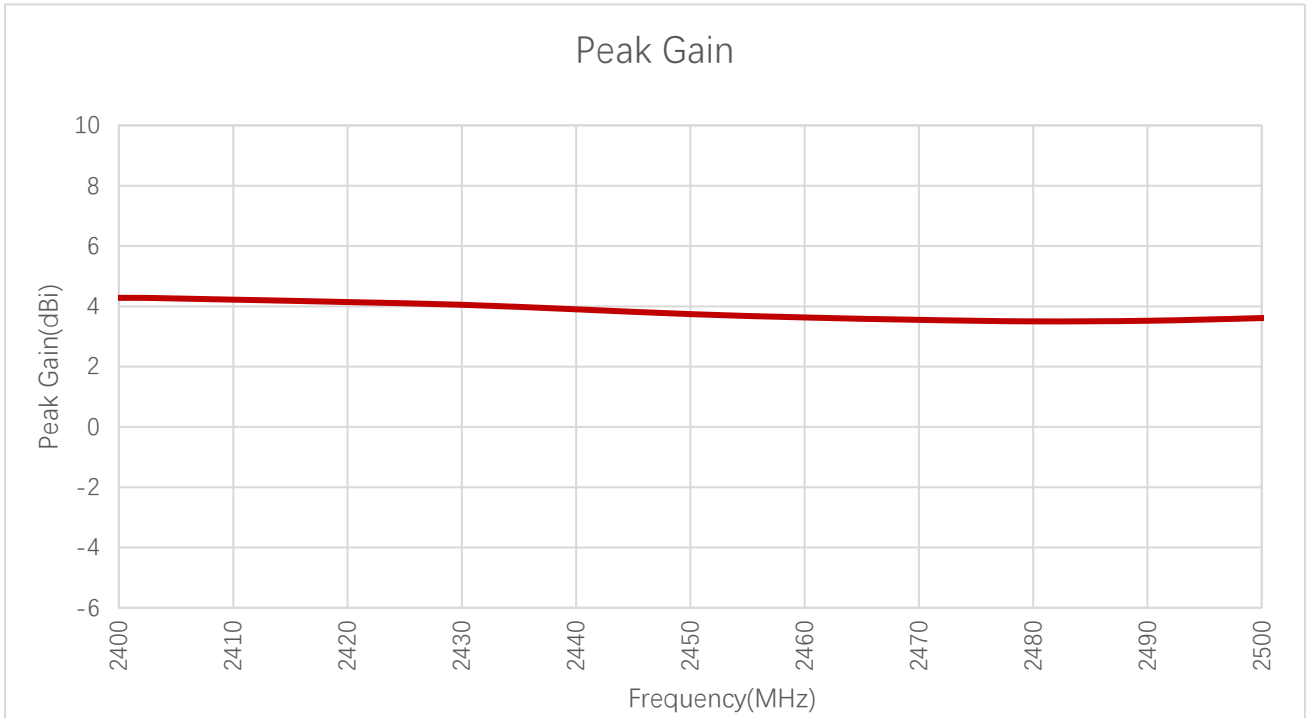

Peak Gain (dBi)

Frequency (MHz)	2400	2450	2500	5150	5500	5850	5925	6525	7125
Peak Gain (dBi)	4.3	3.7	3.6	-	-	-	-	-	-

3.2.4. 3D & 2D Radiation Pattern

- Test Condition: Free Space
- Test Chamber: HF-S-1

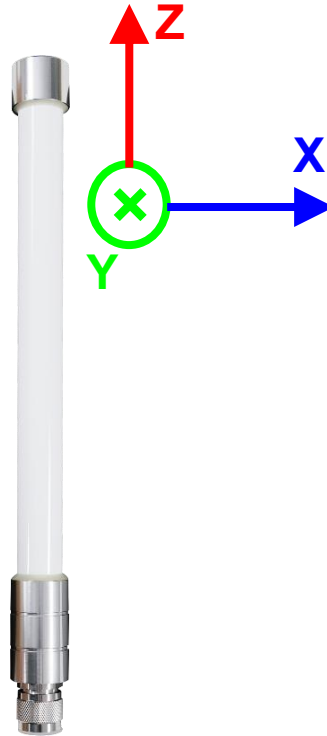

● **Wi-Fi**

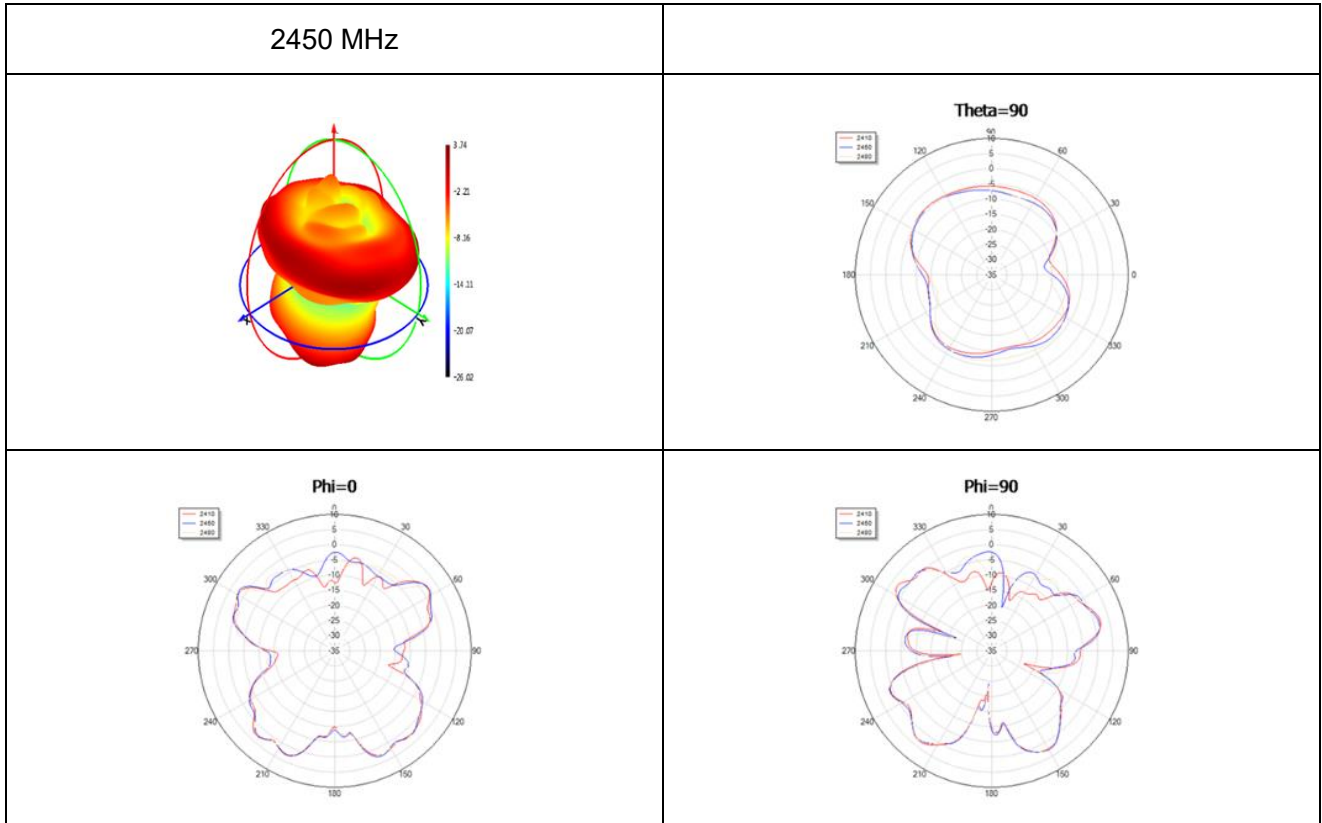

● **Max Peak Gain**

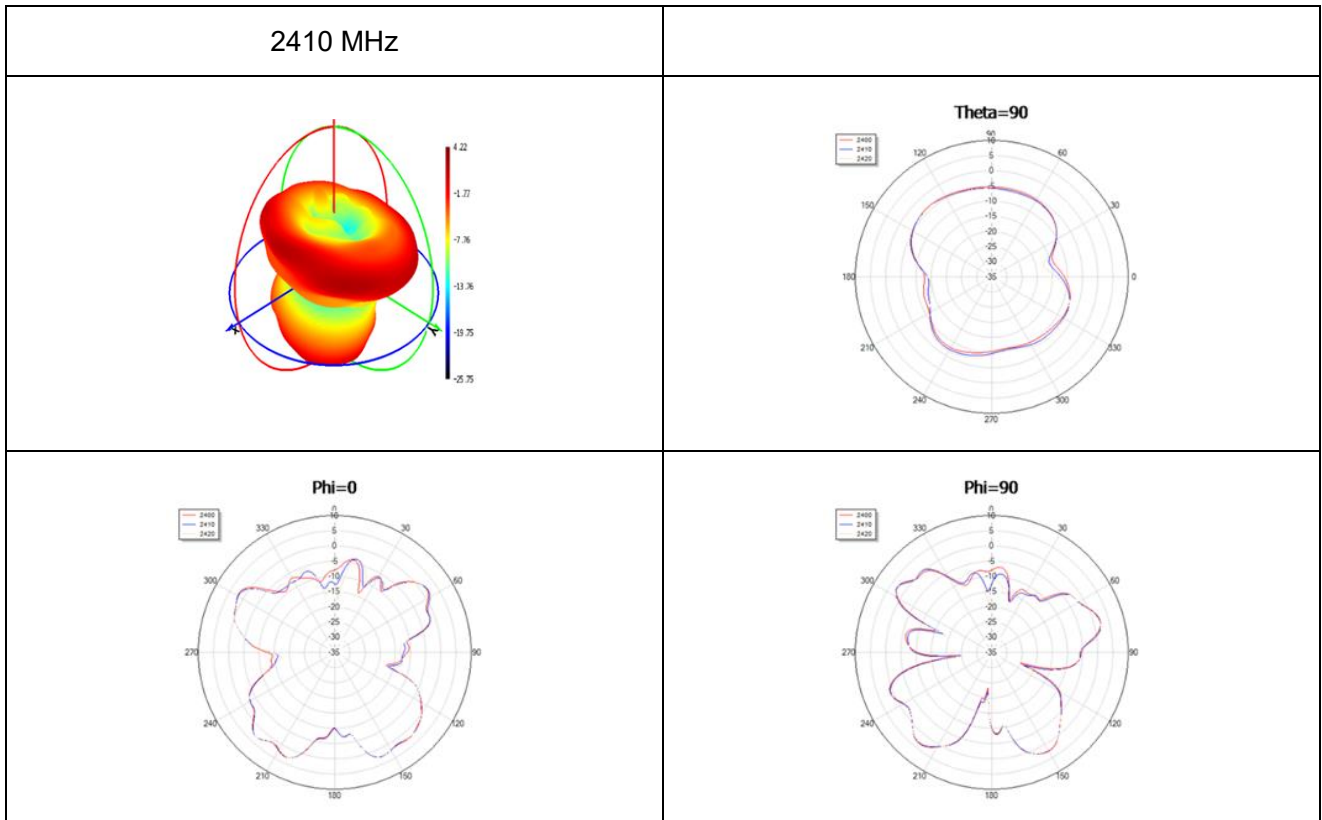

4 Packaging

Step	Packaging Picture / 2D Picture	Description
1		<p>1 antenna product in a bubble bag. (1 Antenna / Bubble Bag)</p>
2		<p>1 antenna product in an inner box. (1 Antenna / Inner Box)</p>
3		<p>Place the inner box into the outer box, place 7 inner boxes on each layer, stack 7 layers, and a total of 49 inner boxes. (49 Inner Boxes / Carton Box) (49 Antennas / Carton Box) Estimated quantity Products that cannot fill the entire carton box are packed in a suitable size carton box. <u>Carton Size:</u> <u>L × W × H = 390 × 275 × 300 mm</u></p>
4		<p>Position for Attaching Labels</p> <ul style="list-style-type: none"> ① Carton Label ② Quality Label

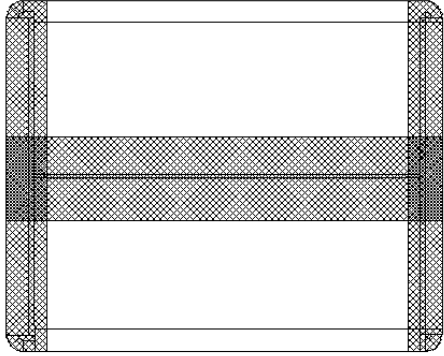
5		Sealing Cartons H-shaped sealing cartons
Note	The initial packaging method described above is for reference only, and the final actual packaging method shall be subject to the actual shipping packaging.	

Contact Us

At Quectel, our aim is to provide timely and comprehensive services to our customers. If you require any assistance, please contact our headquarters:

Quectel Wireless Solutions Co., Ltd.

No. 8 Waipojing Road, Sijing Town, Songjiang District, Shanghai 201601, China

Tel: +86 21 5108 6236

Email: info@quectel.com

Or our local offices. For more information, please visit:

<https://www.quectel.com/contact/>.

For technical support, or to report documentation errors, please visit:

<https://www.quectel.com/tech-support/>.

Or email us at: support@quectel.com.

Legal Notices

We provide this document to support your product design. You are required to design your products based on the specifications and parameters set forth herein. You agree that you are responsible for using independent analysis and evaluation in designing intended products, and we provide reference designs for illustrative purposes only. Before using any hardware, software or service guided by this document, please read this notice carefully. Even though we employ commercially reasonable efforts to provide the best possible experience, you hereby acknowledge and agree that this document and related services hereunder are provided to you on an “as available” basis. You acknowledge and agree that we may add to, amend, or restate this document at any time at our sole discretion without any prior notice to you, and such additions, amendments, or restatements shall be binding upon you.

Use and Disclosure Restrictions

License Agreements

The recipient of any hardware, software, materials, or documentation provided by us shall keep such content confidential, unless expressly authorized by us. The recipient shall not disclose, access, or use any part of the received content for any purpose other than the execution and implementation of the intended project.

Copyright

Our and third-party products hereunder may contain copyrighted materials, including but not limited to protected content, hardware, software, and documentation owned by us or applicable third parties. Unless prior written consent is obtained, you shall not access, use, or disclose any documents or information provided by us, nor shall you copy, reproduce, republish, display, translate, distribute, merge, modify, or create derivative works from any such copyrighted materials. We and the applicable third party retain exclusive rights to all copyrighted materials. No license to any patents, copyrights, trademarks, or service marks shall be granted or transferred. For the avoidance of doubt, no form of purchase shall be construed as granting any license beyond a normal, non-exclusive, royalty-free license to use the product. We reserve the right to pursue legal action against any violation of confidentiality obligations, unauthorized use, or any other unlawful or malicious use of the aforementioned documents and information.

Trademarks

Unless otherwise expressly provided, nothing in this document shall be construed as conferring any rights to use any trademark, trade name, name, abbreviation, or counterfeit thereof owned by us or any third party in advertising, publicity, or any other contexts.

Third-Party Rights

You understand that this document may refer to hardware, software, and/or documentation owned by one or more third parties (“third-party materials”). Use of such third-party materials is subject to all applicable restrictions and obligations set forth herein.

We make no warranty or representation, either express or implied, regarding the third-party materials, including but not limited to any implied or statutory, warranties of merchantability or fitness for a particular purpose, quiet enjoyment, system integration, information accuracy, and non-infringement of any third-party intellectual property rights with regard to the licensed technology or use thereof. Nothing herein constitutes a representation or warranty by us to either develop, enhance, modify, distribute, market, sell, offer for sale, or otherwise maintain production of any our products or any other hardware, software, device, tool, information, or product. We moreover disclaim any and all warranties arising from the course of dealing, course of performance, or usage of trade.

Privacy Policy

To enable product functionality, certain device data may be uploaded to our or third-party servers, including those operated by carriers, chipset suppliers, or servers designated by you. We strictly comply with applicable laws and regulations and will retain, use, disclose, or otherwise process relevant data solely for the purpose of enabling product functionality, or as permitted by applicable laws. Before interacting with any third party regarding data exchange, please be informed of and understand their privacy and data security policies.

Disclaimer

- a) We shall not be liable for any damages resulting from failure to comply with applicable operational or design specifications.
- b) We shall bear no liability for any inaccuracies or omissions in this document, nor for any damages arising from the use of the information contained herein.
- c) While we make every effort to ensure the integrity, accuracy, and timeliness of the features and functions under development, errors or omissions may nevertheless occur. Unless otherwise provided in a valid written agreement, we make no warranties of any kind, express, implied, or statutory, and disclaim all liability for any loss or damage arising from the use of any features or functions under development, to the maximum extent permitted by law, regardless of whether such loss or damage is foreseeable.
- d) We assume no legal responsibility for the accessibility, safety, accuracy, availability, legality, or completeness of any information, content, advertising, commercial offers, products, services, or materials on third-party websites or third-party resources.

Copyright © Quectel Wireless Solutions Co., Ltd. 2026. All rights reserved.

Revision History

Version	Date	Author	Note
-	2025-06-12	Christopher Yao/ Lance Sun/ Riva Ren/ Rainey Liao	Creation of the document
1.0	2025-06-12	Christopher Yao/ Lance Sun/ Riva Ren/ Rainey Liao	First official release
1.1	2026-01-26	Strong Qiang	Updated the packaging (Chapter 4).

QUECTEL

www.quectel.com